

flex7

CI/SfB November 2007
(6-) Xn
Uniclass: L74



Interconnection system

flex connectors
Lighting connection made simple

Contents

flex 7 interconnection system	1
flex 7 hub units, single sockets	2
flex 7 first-in-line units	3
flex 7 flexible interconnection units, multi circuit units	4
flex 7 single extender leads	5
flex 7 twin extender leads	6
flex 7 modular chains	7
flex 7 panel mount plugs and sockets	8
Technical information	9

Ordering flex 7 interconnection products

Flex 7 interconnection products are supplied through electrical wholesalers. To order, contact your local wholesaler or visit our website at www.flexconnectors.co.uk for a list of stockists.

Most of the interconnection products in this catalogue are ex-stock and are usually supplied within 2-3 days of receipt of order. For urgent orders, we can often arrange next day delivery.

We can also create special variations of our interconnection products for you. If a standard product does not suit your installation, contact us on 020 8580 1066 to discuss your requirements and find the right solution.

Technical advice

If you have questions on any aspect of the Flex 7 interconnection range, or would like advice on product selection or usage, please call us. We also have a team of specification engineers who are happy to visit your organisation to demonstrate Flex 7 products and work with you to find the most effective solutions to your current or future requirements.

Quotations service

For larger projects, we offer a quotations service using either drawings or detailed specifications. As well as suggesting the most appropriate products, we prepare a product schedule and can supply the products packaged and labelled to suit the installation requirements.

Contact us

Flex Connectors Limited
Unit 8, The Gate Centre
Syon Gate Way
Brentford
Middlesex
TW8 9DD

Tel: 020 8580 1066
Fax: 020 8580 1062

Email: info@flexconnectors.co.uk
www.flexconnectors.co.uk

Information given in this catalogue is for guidance only, as our policy is one of continuous product development and specifications may change. Flex Connectors Limited is not liable for claims arising from product misuse.

Typical applications for the flex 7 interconnection range

Typical applications

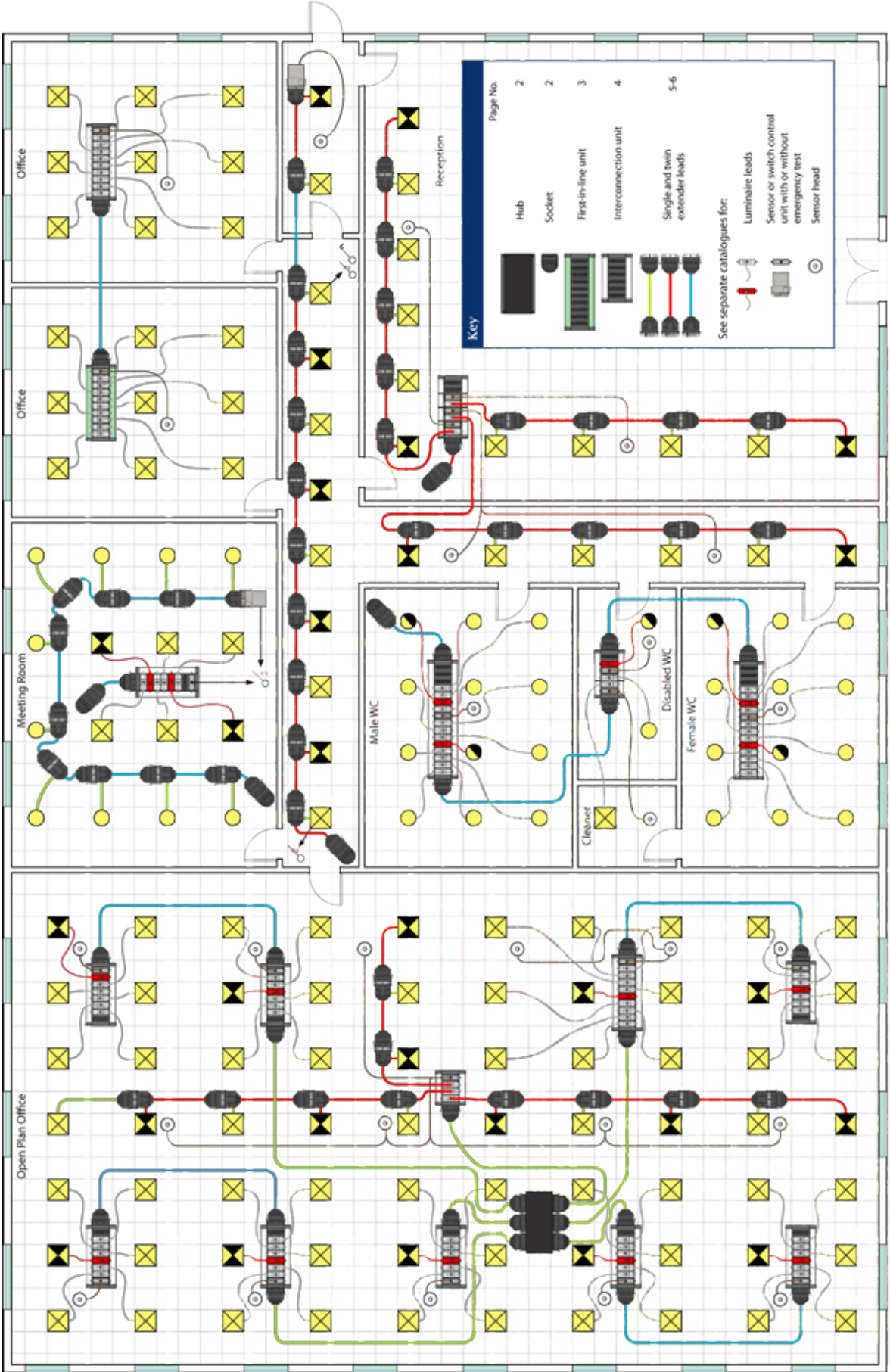

The system

The Flex 7 interconnection system combines total design flexibility with simple plug-together installation to produce an efficient and cost-effective modular solution.

Connecting Flex 7 interconnection units with interconnection extender leads creates a complete, flexible, plug-together, connection unit based system. Using our twin extender system or modular chains provides an alternative 'piggy-back' installation approach.

Whichever solution you select, or whether you choose to mix them, everything just plugs together. If pre-wired hub units are selected for initial connection, they only require termination at the distribution board. The system can also be connected to the fixed wiring via single outlets for conduit or trunking box mounting or by using a first-in-line connection unit.

By factory producing, fully testing and delivering individually tailored systems, Flex 7 interconnection eliminates the uncertainty of on-site interpretation. Wastage and re-working are minimised, whilst layout alterations are quickly and easily accommodated thanks to the system's flexibility.

The compact and lightweight components are clearly and comprehensively labelled, making on-site installation simple and fast. Some Flex 7 interconnection products are manufactured to special order, so please contact us to discuss your requirements.

Key features of the flex 7 interconnection system

- Simple plug-together installation.
- Plug-in control devices.
- Rated at 16A.
- Interconnection and connection up to seven poles.
- Substantial savings in installation time.
- Flexible products that can be adapted for individual projects.
- Special product design and manufacturing service.
- A projects quotation service.
- A company that works with you to meet your requirements and exceed your expectations.

Interconnection system

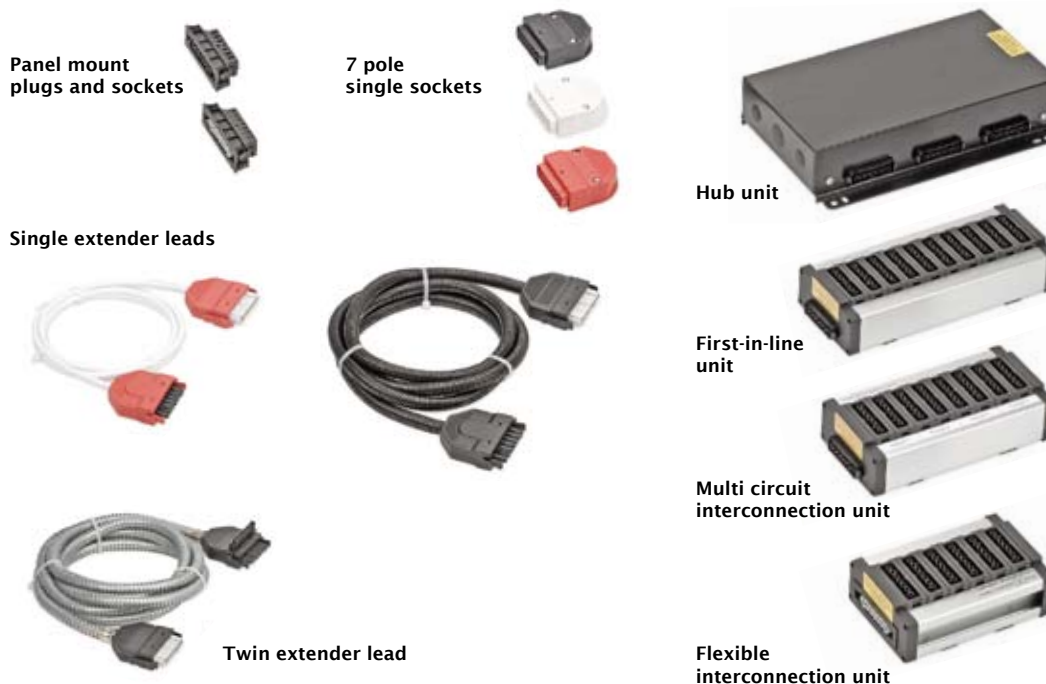

flex 7 hub units

The 6-outlet hub unit is the most effective tool for initiating a Flex 7 interconnection system, with up to six circuits plugging-in for connection to the distribution board.

Each hub outlet has seven poles, allowing central switching and emergency test configurations, as well as the integration of control or signal cables. The completely separate terminations for each outlet permit connection back to more than one phase at the distribution board. A large capacity earth terminal bar gives a choice of earthing arrangements.

Whilst hubs can be supplied unwired, ordering them wired with a SWA home-run tail (to your specified size and length) allows us to undertake full factory testing for you. Both hubs and tails have clear circuit identification labelling – all that is needed on site is connection to the distribution board.

Ordering flex 7 hub units

fhu06 6 outlet hub unit, no cable

For pre-wired hubs, please contact us to discuss your requirements.



Key features

- Six individually wireable 7-pole sockets rated at 16A.
- Easy to fix and wire or test.
- Choice of unwired or pre-wired with SWA tail.
- Substantial earth block included.
- Supply and signal wiring can be supplied from the same outlet.
- Fully compatible with all Flex 7 plugs and extender leads.

flex 7 single socket outlets

The 16 amp rating enables the Flex 7 socket to cope safely with the inrush current when lights are first switched on, making it particularly suitable for the initial connection to any interconnection circuit.

Large capacity terminals and substantial wiring space, combined with a simple-to-remove cover, make the socket quick and convenient to install, particularly where space is at a premium. Removing the cover gives access for inspection without disturbing the wiring.

The socket has 50.8mm fixing centres for conduit box mounting and the Flex 7 trunking mount plate provides a simple way to mount single outlets to trunking, cable basket or tray. Supplied in the



same colour as the socket with a 25mm hole as standard, you can also order it blank or with a 20mm hole.

Key features

- 7-pole sockets, rated at 16A.
- Large, simple to wire terminals with easy access for power screwdrivers.
- 50.8mm/2" fixing for conduit box mounting.
- Supplied with M4 captive fixing screws.
- Also available with trunking mount plate (plain or pre-punched with 20mm or 25mm hole).

Ordering flex 7 single sockets

fts07/b 7 pole single socket, black

fts07/tm/b 7 pole trunking mount socket, black

Other colours available on request.

flex 7 first-in-line units

Flex 7 first-in-line units are supplied with a socket for through connection and with five terminals for supply connection. They are supplied with ten 7-pole socket outlets for plugging-in luminaires or control devices. Control signals can only be connected via plug-in devices.

All subsequent units plug into the first-in-line unit using Flex 7 extender leads (see pages 4 and 5).



Key features

- Seven contacts per outlet, rated at 16A.
- End cap outlet for extender lead connection.
- Ten outlets for luminaire or control device connection.
- Slot on top edge for standard drop rod fixing, plus brackets on two sides.

Ordering flex 7 first-in-line units

fi10t 10 way unit, 5 terminals

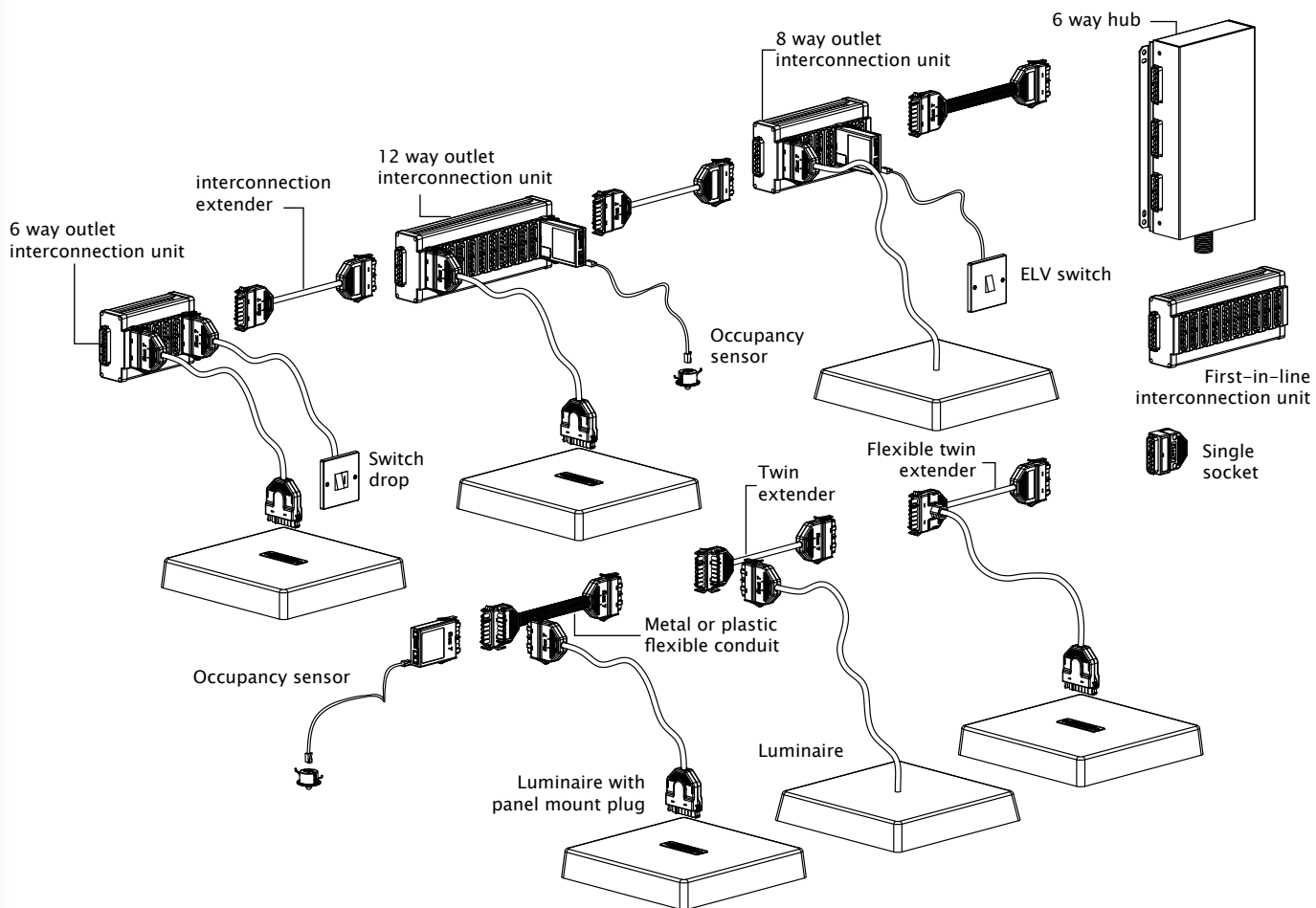

flex 7 flexible interconnection units

To provide contractors with the maximum flexibility when positioning lights, the Flex 7 system has been enhanced by the introduction of units compatible with special extender leads. The range consists of flexible interconnection units with up to 20 outlets.

The units are pre-fitted with plug and socket interfaces, which means any length of pre-wired extender lead can be used for interconnection. The number of conductors in the pre-wired lead is then selected according to the type of interconnection required.



Key features

- Supplied unwired.
- Pre-fitted with plug and socket interconnection interfaces.
- 2 – 20 way outlets.

Lead Application

Lead	Application
3-core	Power connections only, each interconnection unit must have local switching and emergency test facility plugged-in.
4-core	Common emergency test but each unit must have local switching facility plugged in.
5-core	Both switching and emergency test are common for the circuit.

Ordering flex 7 flexible interconnection units

fi <input type="text"/> e	
02 2 way outlet	10 10 way outlet
04 4 way outlet	12 12 way outlet
06 6 way outlet	16 16 way outlet
08 8 way outlet	20 20 way outlet

Ordering flex 7 interconnection single extender leads

fi <input type="text"/> 150lsf <input type="text"/> /b	
3 3-core	Length in metres
4 4-core	
5 5-core	

flex 7 flexible multi circuit units

In response to the increasingly complex lighting installations which public buildings such as schools and hospitals now require, special multi-units for up to four switch or sensor controlled sub-circuits are now part of the Flex 7 range.

Available as interconnection units, 2, 3 or 4 pairs of outlets allow up to four switch drops, ELV

Key features

- Pre-fitted with plug and socket interfaces.
- Ready configured for multiple control circuits.
- 2, 3 or 4 pairs of outlets.

switches or occupancy sensors to be plugged in to control four chains of twin extender sockets or interconnection units. This means up to four rows of lights can then be controlled separately.

Ordering flex 7 flexible multi circuit units

04	4-way interconnection unit – 2 circuits
06	6-way interconnection unit – 3 circuits
08	8-way interconnection unit – 4 circuits

fi m

These units are also available with other configurations or with terminals – please contact us to discuss your requirements.

flex 7 extender range

Flexibility, adaptability and ease of installation – all the benefits associated with Flex 7 lighting connection are an integral part of the new Flex 7 extender range.

Consisting of single and twin extender leads and panel mount plugs and sockets, all items feature the unique Flex 7 interface and are 16 amp rated.

Designed – like every Flex 7 product – specifically for industrial and commercial use, the Extender range plugs together quickly and easily. Fewer connections and less hard wiring reduces the likelihood of errors, saving time – and therefore cost – on the installation.



flex 7 single extender leads

Plugging a Flex 7 single extender into a light fitting means there is no need to hard wire terminations to luminaires. The result is increased flexibility of installation and reduced time and cost on site.

Luminaire manufacturers and electrical contractors no longer have to wire a lead to a luminaire before installation – with the risk that the lead may be too long or, more problematically, too short – because the correct length is selected and fitted after the luminaire is in place.

The luminaire manufacturer simply installs a flush mounting, panel mount plug into the fitting (see page 8). This also minimises packaging and storage, as the plug and lead no longer need to be included. Where an installation requires even greater flexibility of luminaire siting, a short plug and lead can still be fitted to the luminaire.



For interconnection systems, special Flex 7 extender leads pre-wired with 1.50mm² conductors make the connections between interconnection units (see page 4 for selection and ordering criteria).

The Flex 7 single extender is available in a choice of: white, red or black; pre-wired with 1.00mm² and 1.50mm² LSOH flexible cable; 3-core to 7-core; and in 2m, 3m and 5m lengths. Other lengths are available to special order, as are metal or plastic flexible conduit and Flexishield™ leads.

Ordering flex 7 single extender leads

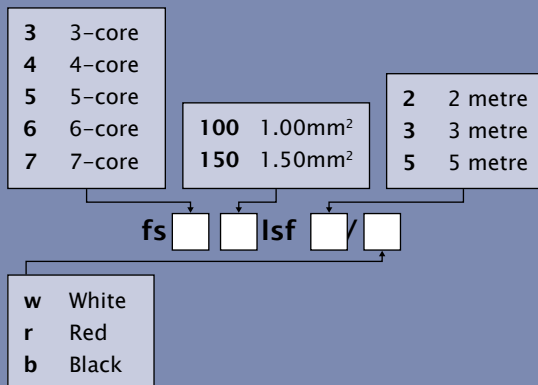

Key features

- Colours – red, white and black.
- Pre-wired with 1.00mm² or 1.50mm² flexible cable, 3-core to 7-core and in 2m, 3m or 5m lengths.
- Other lengths, metal or plastic flexible conduit and Flexishield™ leads available to special order.

flex 7 twin extender leads

The Extender range provides additional lighting connection solutions through the use of a twin-outlet extender. With all the advantages of the single outlet, the twin version has a second outlet available to continue the circuit to the next fitting, using a second lead. This solution is particularly useful where luminaires are sited in rows, such as in corridors or open plan offices, or where the specification requires the luminaire to be sited next to its connecting socket.

Where other products have a separate T-connector – doubling plug and socket connections and therefore potential faults – the Flex 7 twin extender benefits from an integral perpendicular second socket. Metal clips (part no. fb009) for securing the linked sockets to the building fabric are also available.

A further option is available with the Flex 7 twin flexible extender. Whilst similar to the standard



twin extender, this version has the second extender socket on a 1m flexible lead. This eliminates the need for a pre-wired luminaire lead or a single extender lead for final connection to a luminaire when the luminaire is pre-assembled with a Flex 7 panel mount plug.

For systems with plug-in switching, a special Flex 7 twin extender lead is used. A luminaire, an occupancy sensor or an ELV switch can be plugged-in to any outlet on the circuit. 5-core special leads are available for use when plug-in switch, sensor or emergency test units are required. 7-core leads should be used for dimming circuits.

The Flex 7 twin extender is available in black, pre-wired with 1.50mm² LSOH flexible cable in a choice of: 3-core to 7-core; and in 2m, 3m and 5m lengths. Other lengths are available to special order, as are metal or plastic flexible conduit and Flexishield™ leads.

It is recommended that a single extender lead is used to connect to the final luminaire in a row if a control device is not to be fitted.



Ordering flex 7 twin extender leads

fd twin extender lead

ff flexible twin extender lead

Add I if 5-core leads are required for plug-in switching

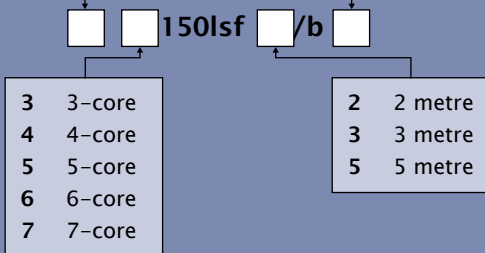

Key features

- Colour – black.
- Pre-wired with 1.50mm² flexible cable, 3-core to 7-core and in 2m, 3m or 5m lengths.
- Other lengths, metal or plastic flexible conduit and Flexishield™ leads available to special order.

flex 7 modular chains

The Flex 7 modular chain allows complete, pre-wired chains of outlets to be factory assembled. Whilst chains created using twin extender leads are plugged together, Flex 7 single socket outlets are permanently connected together, the required distance apart, in order to allow complete runs of lighting points to be installed in one piece.

The 3- and 4-core versions are suitable for standard switched and emergency lighting connection, whilst the 5-, 6- and 7-core versions are versatile enough to cater for digital and analogue dimming connection, multi-circuit switching and control network connection.

Luminaires are pre-wired with Flex 7 plugs and leads of the required length, firmly secured into the Flex chain outlets by means of their strong latches. Circuit control can be provided by hard-wired switching or by allowing an extra socket outlet to plug-in one of the large range of Flex 7 control devices.



Standard wiring is 1.50mm² LSOH flexible cable although larger cable sizes are possible; sockets are spaced 2, 3, 4 or 5m apart; and chain lengths can be from 2 to 16 outlets. Mixed and special spacing are also available – please contact us for details on 020 8580 1066.

Key features

- Up to seven poles per outlet.
- Contacts and outlet rated at 16A.
- Standard versions from 3-pole to 7-pole.
- Plug in luminaires using Flex 7 plugs or pre-wired leads.

Ordering flex 7 modular chains

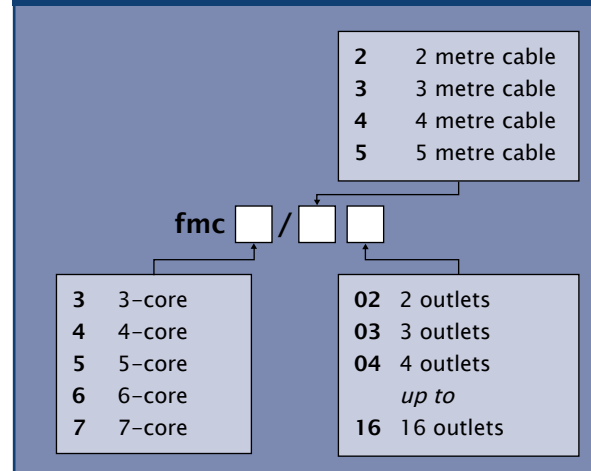

flex 7 flush panel mount plugs and sockets

Available in 3-, 4- and 7-pole versions, the panel mount units enable the Flex 7 interface to be added to luminaires or other equipment, allowing Flex 7 leads to connect to and from the equipment.

Designed with a minimal thickness front plate and a strong snap fixing, the panel mount snaps-in to a rectangular hole in materials from 0.5mm – 1.50mm thick.

Panel mount plugs and sockets are supplied with screw terminals. However, they can easily be pre-wired with your required cables – contact us on 020 8580 1066 to discuss your requirements and obtain a quotation.



Aperture size

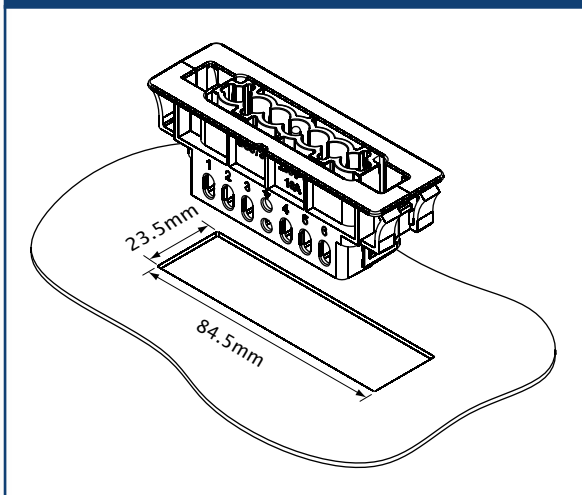

Key features

- Available in 3-, 4- and 7-pole versions.
- Minimal thickness front plate.
- Strong snap fixing.
- Screw terminals.

Ordering flex 7 panel mount plugs and sockets

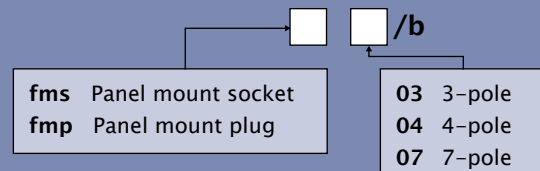

flex 7 interconnection product details

Connectors

230V, 16A ~
BS 5733
All contacts rated at 16A
3, 4 or 7 poles per outlet using Flex 7 outlet format

Information given in this catalogue is for guidance only, as our policy is one of continuous development and specifications may change. Flex Connectors is not liable for claims arising from product misuse.

Conduits and cables

LSOH flexible cable
1.50mm ² to BS7211 dimensions to BS6500 Table 27
LSOH flexible conduit
Nylon corrugated, high strength flexible conduit Low fire hazard -40°C to 120°C. Colour: black
BS EN 50086.1 Class 2 250N BS EN 50086.2.3
Internal cables 6491B LSOH to BS7211 – normally 1.50mm ²
Metal flexible conduit
Galvanised steel helically wound flexible conduit. Colour: zinc self-colour
BS EN 50086.1 BS 731
Internal cables 6491B LSOH to BS7211 – normally 1.50mm ²

Technical information

First-in-line circuit diagram

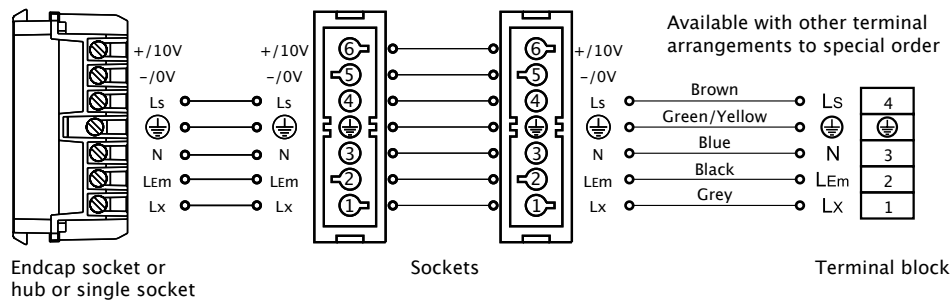

Installing a flex 7 mounting clip

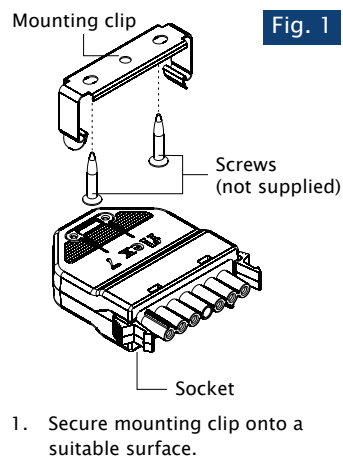

Hanging from ceiling suspension systems

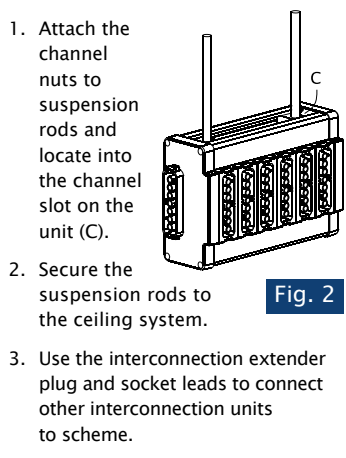

Installing a flex 7 single socket outlet onto a conduit box

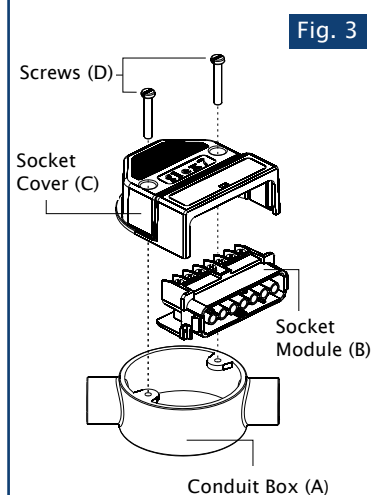

Fixing to a solid surface

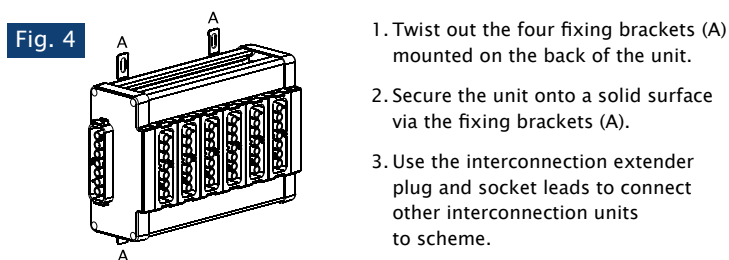

Installing a flex 7 trunking mounted single socket outlet

1. Drill hole into trunking (20mm Ø or 25mm Ø).
2. Secure trunking mount plate (A) onto trunking with a suitable gland and nut (B), not supplied.
3. When ready to terminate, slide and snap socket module (C) on to trunking mount plate (A) and terminate.
4. Fit socket cover (D) using self-tapping screws (E) supplied with the trunking mount plate (A), discard screws supplied with the socket cover (D).

Please note:
We recommend that socket modules are only fitted to the trunking mount plate when terminating, as when the socket cover is removed, drilling vibrations can cause terminal screws to fall out.

