

Heat Mat

Underfloor Heating

Ultra-Thin, 17th Edition Compliant Combymat Heating System

Fitting Guide – version 1

Call 01444 247020 for Technical Support



Underfloor Heating – made easy...

Please ensure you read this guide completely before commencing installation of the underfloor heating. If you are unsure of any aspect of the installation please call Heat Mat's Technical Support helpline on 01444 247020.

Contents

Do's and Don'ts	3
Technical information	4
System and testing information	4
Basic wiring diagram	5
Combination and positioning	6
Installation instructions - Heating Mats	7
Installation instructions - Overlay Boards	10
Warranty information	15
Consumer unit information	Back page

**Before commencing your installation, please check that you have the correct heater or combination of heaters for your chosen area.
(see page 6 for details)**

Heat Mat Limited accept no liability, either express or implied, for any consequential losses incurred as a result of a Heat Mat system installation that does not conform to the following installation instructions.

Do's and Don'ts

- Do thoroughly read this guide before commencing installation
- Do space the mats evenly across the floor to produce a uniform heat output
- Do use the supplied electrically conductive tape to bridge the gaps between each section of mat and cover all exposed cable. Always check the earth connection between sections before installing the floor covering
- Do ensure that all sections of the heating mat are fitted beneath the floor covering or Overlay Boards
- Do ensure the floor base has no sharp debris or objects such as nail heads protruding before beginning installation
- Do cover the Combymat system with a suitable floating laminate floor (10-18mm thick) or Overlay Boards that will conduct heat
- Do use a multi-meter to test each mat before, during and after fitting the final floor covering
- Do connect multiple mats in parallel and ensure that the earth leads for each mat are connected to the earth ring
- Do consider additionally insulating your sub-floor before installing the underfloor heating system
- Do ensure that all electrical works conform to Part 'P' of the Building Regulations and current IEE Wiring Regulations
- Do consult with your builder or electrician to ensure your BTU requirements can be met (if using the heating system as your primary heat source)
- Do place all acoustic, insulation and damp proof membranes beneath the heating system, not on top, and ensure they are suitable for use with electric underfloor heating
- Do ensure the system is protected by a suitable RCD (30mA)
- Don't cut, shorten, strain or cross the heating cables or bend the joint between the heating element and the black coldtail
- Don't use the Combymat system beneath tiles or in bathrooms or wet areas
- Don't use the Combymat system with laminate or engineered board floors that use a glued locking system or a metal fixing strip, or have an integrated layer of insulation
- Don't turn on the system to maximum power once the floor covering is down, you should increase the temperature of the system slowly over a course of weeks
- Don't lay the system so that any pairs of cables cross over other pairs of cables or run parallel to them closer than 20mm
- Don't place mats closer than 50mm away from conductive items such as drains, metal pipework or within walls
- Don't walk on the heating system during installation. If you need to walk over the underlay or heating, distribute your weight with ply or laminate floor planks
- Don't overlap heating mats or start your installation before you have planned it out
- Don't place thermal blocks onto your finished floor covering above your mats when they are in use. Such items include large bean bags, thick rugs or floor flush furniture
- Don't install the system if the ambient temperature is below 5°C as the cables can become less flexible
- Don't install the mats in walls or ceilings
- Don't install the floor temperature sensor close to other heat sources such as hot water pipes

Combymat System 150W/m² technical specification

Product Code	Size in m ²	Length in Metres	Width in Metres	Wattage	Resistance (Ohms) -5 /+ 10%
CBM-150-0100	1.0m ²	2.0m	0.5m	150	378
CBM-150-0150	1.5m ²	3.0m	0.5m	225	252
CBM-150-0200	2.0m ²	4.0m	0.5m	300	189
CBM-150-0250	2.5m ²	5.0m	0.5m	375	151
CBM-150-0300	3.0m ²	6.0m	0.5m	450	126
CBM-150-0350	3.5m ²	7.0m	0.5m	525	108
CBM-150-0400	4.0m ²	8.0m	0.5m	600	94
CBM-150-0450	4.5m ²	9.0m	0.5m	675	84
CBM-150-0500	5.0m ²	10.0m	0.5m	750	76
CBM-150-0600	6.0m ²	12.0m	0.5m	900	63
CBM-150-0700	7.0m ²	14.0m	0.5m	1050	54
CBM-150-0800	8.0m ²	16.0m	0.5m	1200	47
CBM-150-0900	9.0m ²	18.0m	0.5m	1350	42
CBM-150-1000	10.0m ²	20.0m	0.5m	1500	38
CBM-150-1200	12.0m ²	24.0m	0.5m	1800	31
CBM-150-1500	15.0m ²	30.0m	0.5m	2250	26
CBM-INS-0006	6m ² of insulation for Combymat				
CBM-ALU-TAPE	20 x 40mm aluminium conductive tape for Combymat				
CBM-OVE-Q280	2.88m ² of 7mm of Combymat Overlay Boards				

General Construction:	Ultra-thin 1.2mm heating cable sandwiched between twin layers of aluminium	Power Range:	150W to 2250W
Voltage:	240 Vac – 50Hz	CE Marked in accordance with:	EN 60335-2-96
Maximum Load:	150W/sqm	Thermal Conductor:	Fluoropolymer coated resistance wires
Wire Thickness:	1.2mm	Earth Shield:	Aluminium foil
Cable Flexibility:	Minimum bend radius 25mm	Heat Dissipation Materials:	Full coverage aluminium foil
		Factory Testing:	2 seconds at 2.5kV (EN30335-2-96)

Testing your Heating Mat with a multi-meter

Test each heating mat with a multi-meter before unwrapping to confirm you have received it in working order. The black coldtail is insulated and carries an earth and live and neutral wires.

The continuity and resistance tests can be carried out on these wires and should also be carried out before, during and after fitting the final floor covering.

After installing the heating mats and aluminium tape, a suitably qualified electrician must verify that all cut sections of the mat have a sufficient earth connection that complies with the relevant local standards.

If your tests do not conform to the expected results please contact Heat Mat's Technical Support Team on 01444 247020 for guidance.



Tests

- Live to neutral = ohms value as listed above
- Live to earth and neutral to earth = both infinity
- Ensuring all aluminium surfaces are earthed:

The electrician carrying out the final electrical checks before laying the floor covering must ensure that all sections of the aluminium above the heating mat are connected to the earth. In reality, this often means checking the connection between the furthest section of the heating mat back to the earth braid. Care should be taken not to damage the heating cables during the process (if piercing the aluminium layer).

Basic wiring diagram

Typical Wiring System

- All electrical works must be carried out by a certified electrician.
- A suitable RCD protection (30mA) must be incorporated in this system.
- If the ampage of the thermostat is exceeded by your chosen system, a contactor or similar device will be required. All thermostats used must have a minimum opening between the contacts of 3mm.
- The heating cables must not be cut or cross each other or other wiring.
- Electrically conductive tape must be used to make an earth connection between each section of heating mat, and this connection must be confirmed as suitable before commencing laying the floor covering.
- Please consult your electrician to discuss your individual requirements.

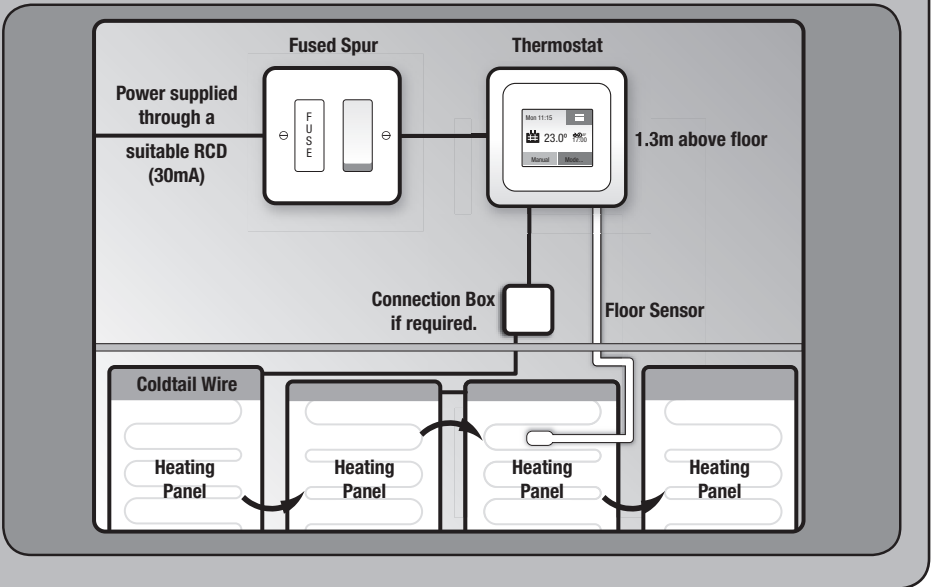

Please see the back page of this fitting guide for the required information label for the distribution board.

It is a legal requirement that this label is completed and the required information is displayed near the relevant distribution board.

Choosing the correct combination and positioning your Combymat Heaters

Heat Mat's Combymat heating system contains ultra-thin heating wires and an aluminium earth shield. Most floating laminate and engineered board floors between 10 and 18mm thick can be laid directly on top of the heating system; if the laminate floor includes a plastic locking system at the end of each board you must confirm with the manufacturer if it is suitable for installation directly above the heating system. If it is not suitable Overlay Boards should be used.

Carpet, vinyl, linoleum and bonded wooden floors can be installed onto Heat Mat Overlay Boards placed above the heating system. Heat Mat's Combymat System is particularly suited to large, regularly shaped rooms, where planning the installation is particularly simple. In smaller (less than 4m²) or more complicated rooms the system requires additional planning to ensure that your installation runs smoothly.

The heating mats can be cut and turned, but they must not be bent or shortened and you should ensure that no matting is placed under any fixed units or beneath internal wall partitions.

The first step is to calculate the coverage of heating mat that you require. Although 100% coverage is achievable we would recommend allowing a border of between 20 and 40mm around the edge of the room. Calculate the internal dimensions (skirting board to skirting board) of your room and using these amended dimensions sketch out a diagram of your room and calculate the total area that you have.

Take this total area and deduct approximately 10% from it if your room is less than 8m² and 7% if it is greater than 8m². We would then recommend installing heating mats totalling this calculated area.

For instance: You have a dining room that is going to have a floating laminate floor and the internal dimensions, skirting board to skirting board, are 4.14m by 6.37m.

We would suggest multiplying these dimensions together, and then deducting 7% from the remainder as the room area is greater than 8m².

The calculation would be as follows:

$$4.14\text{m} \times 6.37\text{m} = 24.53\text{m}^2, \text{ less } 7\% \\ (\text{as the room is above } 8\text{m}^2) = 24.53\text{m}^2$$

Referring to the table of possible mat sizes on page 4 we can see that a possible combination would be two 10.0m² mats and one 4.5m² mat giving a total coverage of 24.5m² (we recommend using the lowest number of mats possible).

We would recommend spending ten minutes sketching this out, as it can save you a lot of time during the installation process if you have a plan.

To simplify your installation the heating mats are provided with 3m coldtails as standard. These can be extended by a suitably qualified electrician or, alternatively, you can cut the heating mat between the cable to provide you with loose sections of the heating wire still affixed to a section of the foil.

These loose wires can then be laid out effectively extending the coldtail, however all wires must be covered with aluminium tape to help them dissipate their heat and ensure they are earth shielded. If you choose to use the heating wires in this way they must all still be laid flat on the floor.

We suggest placing the largest heating mat you have first. Start by planning to lay your heating mat from the wall with your thermostat on and run it to the far side of the room. You should then return the heating mat to the wall with the thermostat on it parallel to the previous run. Continue drawing out the diagram in this method until you have no further linear metres of mat left.

You should then design where the next heating mat is going to be placed and we would suggest starting this where the other heating mat finished. Continue this process until you have designed your entire floor layout and, at this point, if you find the layout will not allow your coldtails to reach the thermostat easily, you can re-design the system without having laid out a single heating mat.

Please note, the coldtail connection and end termination must never be placed in areas that may have heavy furniture or a thermal block placed on top of the floor.

Installation instructions

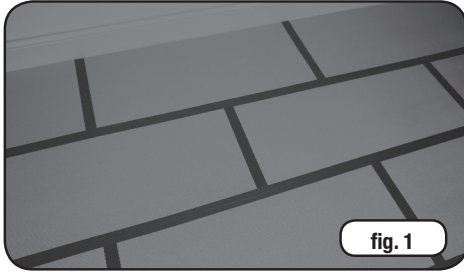

fig. 1

Floor preparation

Ensure the sub-floor is solid, level and dust free. There should be no sharp debris or objects protruding from your base before you begin the installation. The subfloor must be dry and if there is a risk that moisture may be drawn up through the floor then a suitable damp proof membrane must be fitted beneath the 6mm insulation layer. Ideally the sub-floor should be insulated to current building regulations.

Installing your Combymat system

You should always consult a specialist floor layer to check their recommendations for installing your flooring above a direct acting underfloor heating system. In general Heat Mat advises each room is controlled as a separate system and that with solid floors an expansion gap is left between each room, and also between any significantly large unheated areas and the heated floor sections in the same room. If you or your floor fitter have concerns that the floating floor surface you have chosen will not be evenly supported by the underfloor heating system you can use Heat Mat Overlay Boards to solve this problem.

To ensure a completely even floor surface you must cover the entire floor base with Heat Mat's 6mm soft insulation board which should be laid grooved side up. Boards should be fitted even where no heating is going to be laid. The 6mm boards should be laid out in a tessellating pattern similar to the way house bricks are placed in walls (fig.1). The boards can easily be cut with scissors or a utility knife, and once they are laid out on the floor, you should tape the joins between the boards with duct tape or equivalent tape. The boards must not be secured to the floor base itself and you should take care not to crush the insulation boards during the installation process.

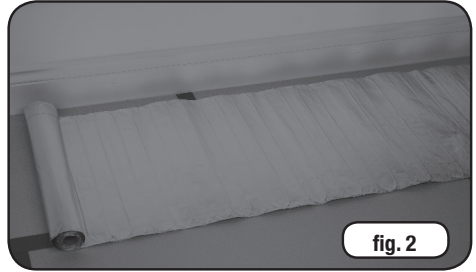

fig. 2

In the thresholds of doors we recommend securing a 20mm wide x 5mm high wooden block to the floor across the entire threshold width, to ensure the floor above is suitably supported in this high traffic area. No insulation should be placed beneath this block.

Test each mat with a multi-meter before unpacking to ensure you have received the product in full working order (page 4). You should now roll out your Combymat heating mats, and place them in accordance with the diagram you previously made (fig.2). The mats should not be bent or twisted and they should lie flat on the floor.

Roll out your first heating mat onto the floor and continue until you reach an obstruction such as a wall. You should now lift up the end of the heating mat and, being careful to avoid cutting the cable, you should cut through the aluminium foil and clear acrylic from one side of the mat to the other (fig.3). You should ensure that you do this between the correct cable run to allow the mat to turn the way you desire. The mat can then hinge back on itself at the point where the two cables now join the two sections of the heating mat and you can start rolling out the mat in the opposite direction (fig.4).

In awkward areas you can cut between a number of the runs of wire on the heating mat to provide you with runs of cable that can be laid out into thin areas. If you need to bend this cable you should carefully cut the remaining foil either side of the cable to allow it to turn more easily. When laying the cable in this manner try to keep the spacing between the cables similar to that on the mat to maintain an even output across the floor area and never let the pairs of cable touch or cross, they should always remain at least 30mm away from each other.

Installation instructions

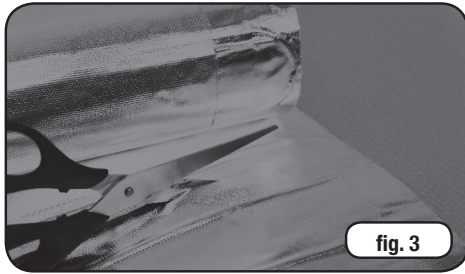

Once you have successfully placed all of your heating mats and coldtails onto the floor you must cut out the insulation beneath the manufactured connections and the coldtail leads with a sharp knife so that they do not stand proud of the insulation (fig.5). You can use double-sided tape beneath these sections to hold the heating mats and loose cable on the floor if you wish.

The manufactured connections are located at either end of the heating mat and are thicker than the rest of the matting. The first is where the black coldtail lead meets the heating cable between the aluminium layers, and the second connection is at the far end of the heating mat - both can be felt through the aluminium.

Once all of your heating mats are lying flat you must use the supplied electrically conductive foil tape to tape between the runs of heating mat. The tape must overlap the edges of each mat by at least 5mm and should also cover any exposed heating elements. All tape must be pushed down firmly onto the surface below to ensure a good bond.

This tape is vital as it ensures that earth protection is present above the heating system. You should now lay the floor sensor for your thermostat between two runs of the heating cable in one of the mats. To obtain the most accurate temperature reading you should position the floor sensor at least 30cm from the edge of the room in an area where no items will be placed on top of the flooring.

Cut a channel in the insulation where you wish to lay the floor sensor and line this with aluminium foil before placing the floor sensor on top. You should then use a section of aluminium tape to hold the floor sensor in position, this will ensure that the sensor picks up an accurate temperature reading from the floor.



If you are going to be installing Overlay Boards the sensor should be installed in a different way once these boards are in place (see page 13).

Now the system is fully installed, a suitably qualified electrician must carry out the electrical checks on each heating mat to ensure that they are in full working order. In addition to the standard electrical checks an earthing test must be carried out between every section of the heating mat and the earth connection of the mat to ensure that a suitable earth connection has been made.

Laying your floor

Your laminate or engineered board floor covering or Overlay Board (see page 9) can now be laid. Please take care when working above the system by wearing soft soled shoes and by using a robust layer to protect the system when you need to stand or kneel on it. Should any of the heating mats/wires be damaged during the installation of the flooring please contact Heat Mat's Technical Support Team on 01444 247020 for advice, as the mats themselves cannot be repaired.

If you are not laying your floor covering straight away the system should be covered by a layer of cardboard or carpet and you should avoid walking over the system where possible. Your electrical checks should then be carried out again before installing your final floor covering.

The Combymat system is particularly suitable for use beneath floating laminate floors and wooden floors where it's low build height, and ease of installation without any wet trade, make it a simple-to-fit solution. It is not suitable for use beneath floor coverings that require gluing or bonding in position unless covered with Overlay Boards, and the system must never be used in wet areas.

Installation instructions

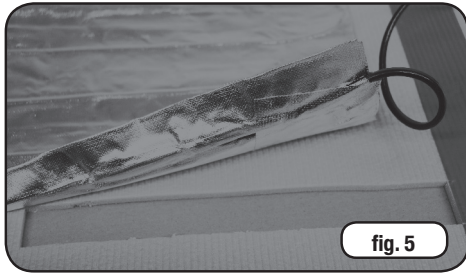

fig. 5

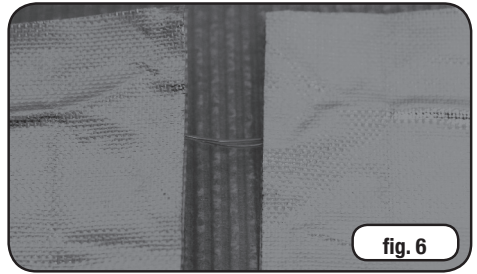

fig. 6

When installing this system beneath a floating laminate or engineered board floor you should confirm with the flooring manufacturer/installer that their flooring is suitable for use directly above an electric underfloor heating system. If the laminate floor being laid contains a plastic spacer at the end of each board it may be necessary to install Overlay Boards before laying the flooring. These types of boards can be prone to movement unless the floor is 100% level, which the Overlay Boards should achieve. We recommend the flooring is laid directly onto our heating system, however if you are installing some form of acoustic insulation or a membrane on top of the heating system before laying your flooring, you should ensure that this insulation/membrane allows heat through efficiently. The layer should have a Tog rating of less than 1.0 Tog and you should confirm with the manufacturer/installer that it is suitable for use with electric underfloor heating in this way and can cope with the associated temperatures. Under no circumstances should any form of cellulose insulation be used with the heating system.

Electrical connections

Wiring can now be completed and all work must comply with current IEE wiring regulations and installations must comply with Part 'P' of the Building Regulations. Consult your Local Authority Building Control department regarding their requirements for certification or check with an electrician qualified to issue Part 'P' certification regarding your individual installation.

The heating mat/s have to be wired into a thermostat with floor temperature limitation. Please see the separate instructions in your Heat Mat thermostat box.

Run the coldtail connections and floor sensor cable in separate plastic conduit or trunking from your heated floor to the thermostat position.

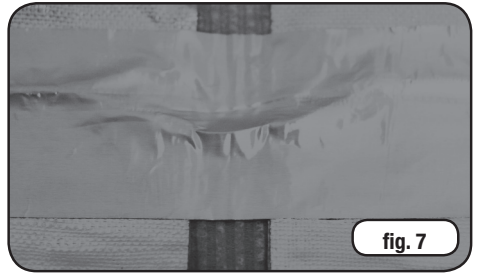

fig. 7

Up to 2 heating mats can be wired straight into the thermostat. A connection box will be required if installing 3 or more heating mats. Ensure that multiple mats are wired in parallel, not in series.

The mains power supply must be protected by a suitable RCD (30mA and up to 4.8kW).

The thermostat should be connected to the power supply via a suitably rated fused spur or circuit breaker.

Heat Mat's thermostats are usually rated to 16 Amp and if the total loading from a combination of heating mats exceeds this, the system will require multiple thermostats, or we would recommend the installation of a suitable rated contactor, which would allow the heating system to be run through a single thermostat for ease of control.

If the thermostat is placed outside the room to be heated, or inside a cupboard, the thermostat will have to be reprogrammed (when first switched on) to only monitor the floor sensor that has been placed into the heated floor space.

Combymat Overlay Board Instructions

Overview of use

Combymat Overlay Boards allow Combymat electric underfloor heating to be installed beneath carpet, vinyl, rubber, bonded engineered board and linoleum floor coverings without needing to cover the heating system with levelling compound. These floor coverings can be fitted directly on top of the Overlay Boards, while the 6mm thick underlay used beneath the Combymat system provides cushioning from movement/walking impact. Any floor covering and underlay fitted onto the Overlay Boards must have a sufficiently low combined Tog rating of 1.8 Tog or less to allow the heat from the underfloor heating system to heat the room. The greater the Tog rating of the floor covering the longer it will take for the system to heat the floor. The Overlay Boards are installed directly on top of the Combymat system which should be installed by following the instructions on page 7.

Special attention should be paid to the following installation guidance:

- **The Combymat and Overlay Boards cannot be used in wet or damp areas such as bathrooms.**
- **If there is a risk of moisture rising up through the floor, a damp proof membrane must be installed directly beneath the 6mm insulation the Combymats are laid onto.**
- **When installing the Combymats you should lay a 20mm wide x 5mm high baton in the threshold of all doorways (without any insulation beneath it) to ensure the Overlay Boards are correctly supported.**

For fixing carpet onto the Overlay Boards it is recommended to use a tackifier adhesive or the double stick method of carpet installation. If using the stretch method of installation the gripper must be installed before the electrical heating system. In order for the gripper to function correctly, the top surface of the gripper should be level with the top surface of the Overlay Boards or underlay. This can be achieved by using a timber spacer beneath a conventional gripper to raise it to the correct level. The Overlay Boards must be kept in a dry environment and free of any moisture.

Overlay Board Fitting Instructions

Overlay Boards must acclimatise in their sealed packaging in the room where they are to be fitted, for at least 48 hours before installation, at a temperature of at least 18°C. Before starting your installation of Overlay Boards ensure your sub-floor is permanently dry, clean and free of dust. We recommend when cutting the boards that you use a retractable concave bladed knife or similar. Score the boards two or three times on the upper surface and then snap the boards along the cut always bending them upwards to break them. This avoids creating sawdust which would prevent the adhesive from bonding correctly. The heating system must be switched off before installing the Overlay Boards.

Installation Overview

The Overlay Board system consists of two self-adhesive components, baseboards and top boards, which bond to each other. The boards create a floating sub-floor which must not be mechanically fixed or bonded to the floor below. Each layer is laid out with staggered joints and arranged so that the top boards overlap the joints in the baseboards. The baseboards are thinner (3mm) and have a protective plastic film to keep the self-adhesive coating clean. This is laid facing upwards and the film is left in place until cutting and fitting is completed.

The top boards are thicker (4mm) and have no plastic film over the adhesive coating. Sometimes the top boards become firmly stuck together during transit; to separate the boards we recommend firmly holding the top of them while placing the bottom of the boards on the ground against your foot. Use your knee to firmly push the centre of the boards forward and they will bend and separate. Once the cut is 10mm or so in between the boards they will separate easily. When installing the top boards you must carefully position them, adhesive side down, so that they overlap all the baseboard joints and abut each other without gaps.

It is important to check that any trimming of the top board is accurate and that the adhesive coating is free from dust or fragments, before removing just enough of the protective film from the baseboards to allow the top board to be bonded in place. The adhesive will allow adjustments to be made for accurate positioning until pressure is applied, but once pressure is applied the boards should not be pulled apart.

Tapping down with a rubber mallet will ensure close contact of the adhesive coatings and produce a strong, permanent bond. Take care to position boards accurately as it is very difficult to separate them once bonded. If the floor finish is to be glued to the Overlay Board surface, the heating system must not be switched back on until the glue has set completely. Temperatures should then be increased gradually.

When installed correctly the overlay boards create a stable and level floor above the heating system allowing a wide variety of floor coverings to be installed directly on top of them. **To ensure that the boards provide this level surface it is vital that you follow the instructions below and install the boards in the order as described.**

Rather than laying all of the base boards first you should install sections of these base boards starting off in one corner, and when enough base boards have been laid, you should lay a section of the top boards as shown in the diagrams. Working in this way ensures that all of the boards are laid closely together and ensures that there are no gaps between the top boards.

At the start of the installation you will need to cut some of the boards and you should make sure that the cut sides are placed towards the wall. An expansion gap of between 8 and 10mm should be left around the perimeter of the room and against all fixed objects. An expansion gap of 8mm should be left in doorways, and this should be increased to 16mm if a system is installed on both sides of the doorway.

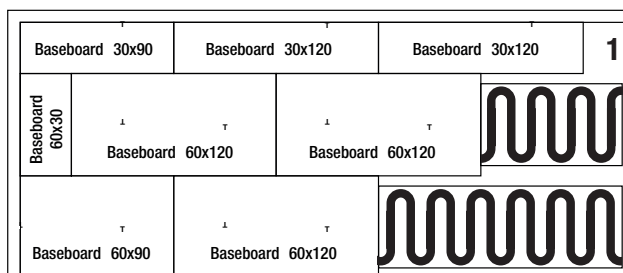

Baseboard first row (picture 1)

The first row of baseboards is created by splitting boards in half lengthways and turning the cut edges towards the wall; the base boards have the plastic film on them and this should be face up. The first piece is shortened to 3/4 of its length with both cut edges against the walls in the corner. Lay out the other pieces end to end in a line along the wall, adhesive side up, leaving the protective film in place. **Leave an expansion gap of 8-10 mm around the whole perimeter and around pipes or other fixed objects**, this also applies to the final floor finish. The boards have markings on them to help you judge your cuts, and we recommend using one of the top boards as a guide for your knife when cutting the boards, to ensure you obtain a straight edge.

Baseboard second row (picture 1)

Boards in the second row are laid out in the same direction as the first row. Start by cutting a full board to 1/4 of its length and place this piece, with the cut end to the wall, next to the first row. Now place a full sized baseboard end to end with it and alongside the first row. The large off-cut will be used to start the third row of baseboards (picture 1). Do not remove the protective film at this stage and keep the boards clean and free from dust.

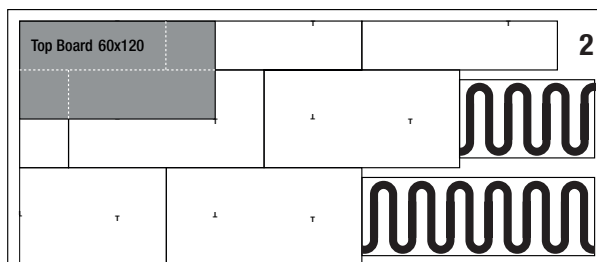

Top boards first row (picture 2)

The top boards are laid in the same direction as the baseboards, but with the adhesive side down. The first board of this row is full size and positioned into the corner overlapping both the first and second rows of baseboards (picture 2). If the board fits neatly into the corner no trimming is required, in which case it can be lifted out and the plastic film can be peeled back from the baseboards that it will cover. Avoid removing more film than is necessary to accommodate the top board on the adhesive. The top board is carefully repositioned and adjusted for alignment, at the same time the baseboards should be checked for any gaps and adjusted if required; finally the top board is fixed in place by tapping down with a rubber mallet.

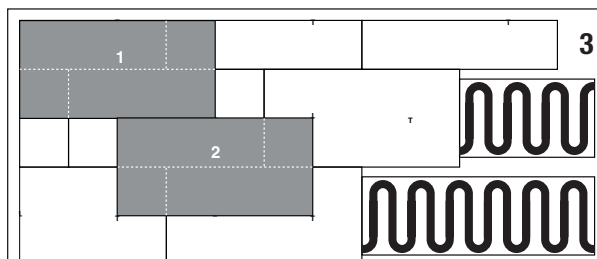

Top boards second row (picture 3)

For the best result it is important to keep the joints between the top boards as tight as possible. The easiest way to achieve this is by starting the second row of top boards with a half-length piece, followed by a full board and pushing all the edges tightly together before tapping down. Boards should be laid in the order shown on the diagram; 1,2,3,4 etc.

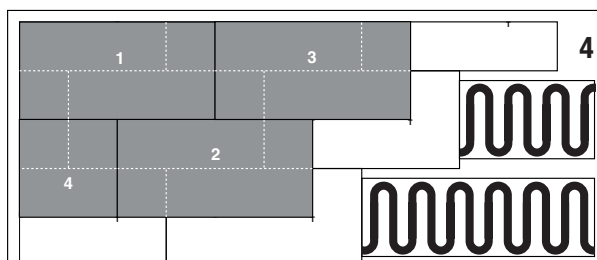

Adding further boards, alternately, to the first two rows keeps the lines straight and prevents gaps from developing (picture 4).

Always check the finished Overlay Board sub floor for irregularities. **Any irregularities of the joints can easily be sanded away with a 120-grain fine sand paper (picture 6).** Vacuum clean the finished Overlay Board sub floor before fitting the floor covering.

When resilient floor coverings are to be glued on to the Overlay Boards, the boards must be fitted 24 hours before laying the floor covering. For the best result and because of possible influences of air humidity, you must glue the floor covering onto the Overlay Boards within 48 hours of their installation.

For run lengths over 10m length, add 1mm per extra metre to the expansion gap around the perimeter of the room. The maximum advised length of floor is 12m, for larger floors please contact Heat Mat for advice. Every room is to be fitted separately, leaving an expansion gap of at least 8 -10mm around the perimeter and 16mm in door openings when Overlay Boards are continued in the adjoining area.

The floor covering should be glued onto the total surface of the Overlay Boards and must not go beyond the edges of the boards. Tap or roll all the top boards with a rubber mallet or a 75kg roller to ensure all boards are properly adhered to each other.

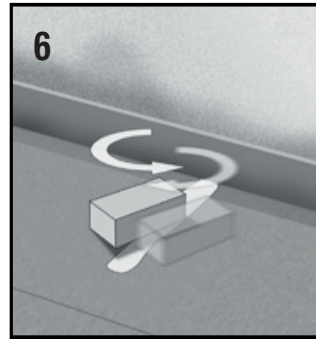
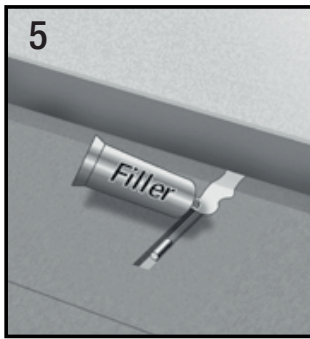

Heating System Floor Sensor Installation

Special attention should be made to the location of the floor sensor and it should be installed as close to the floor surface as possible, and be located in an area directly above a heating element in order to achieve accurate control. A wide groove should be made in the top layer of the Overlay Board to take the tip of the sensor and allow the sensor cable to run to the edge of the room without causing a raised area for the final floor covering. The groove and sensor should be entirely covered with flexible filler to ensure an accurate temperature reading and a smooth and level finish to the Overlay Boards. We recommend that the maximum floor temperature on the thermostat is set no higher than 32°C when using the Overlay Boards. Care should be taken to select a filler that will not react with the floor finish.

Living with your underfloor heating system

To ensure that your system works to its full capacity for the lifetime of the flooring, please ensure that thermal blocking is avoided above the heating system.

Thermal blocks are any items that prevent heat escaping from the floor, and include items such as beanbags, furniture without any air gaps beneath it and thick or rubber backed rugs.

Thermal blocking occurs when the heat produced by the system warms the floor surface but is then trapped and has no way of escaping from the surface of the floor.

This can cause the system to overheat in the thermally blocked area and, in extreme cases, affect the integrity of the floor covering and heating system.

Please note that the Combymat system is not suitable for use in wet areas such as bathrooms.

When you first turn on your underfloor heating system after installing your floor covering you should take care to increase the floor temperature slowly over a number of weeks. If your floor manufacturer has instructions on the process they recommend please follow these. In the absence of any manufacturer's instructions we would suggest limiting the floor temperature initially to 25°C, and then gradually increasing this to 32°C over the course of two weeks. This process should ensure that the floor does not rapidly heat to too high a temperature, which could lead to movement within the floor.

Although care should be taken with underfloor heating when it is used with laminate and wooden floors, it should be remembered that laminate and wooden floors are often exposed to high temperatures when they are installed in conservatories without ill effect.

If you have particular concerns that your floor may suffer from thermal blocking once the heating is installed, you should consider using conventional heating mats covered with levelling compound, as this compound is very efficient at dissipating the heat that can build up beneath a thermal block.

Remember:

If you are unsure how to proceed at any stage of the installation process, please contact Heat Mat's Technical Support Team on 01444 247020.



Heat Mat Lifetime Warranty



Congratulations on your purchase of a Heat Mat electric underfloor heating system

Your earth shielded Combymat heating mat has been supplied in the European Union by Heat Mat Limited, and the following Warranty is provided in accordance with the general product liability rules, as stated in Directive 85/374/CEE, and all relevant national laws. **You are initially provided with a fifteen year warranty on the ultra-thin heating mat for eventual defects in material.** Details and evidence of defects have to be presented to Heat Mat or an authorised distributor for approval.

When your warranty is invoked, your damaged product will either be repaired or replaced free of charge to yourself.

Your warranty does not cover the following:

- Any faults caused by misuse.
- A system which has not been installed in accordance with the manufacturer's guidelines.
- Any other subsequential or consequential damages.
- Any system that has not been paid for in full.

Heat Mat Limited are covered by an international insurance covering warranty payments.

Lifetime Warranty extension

In addition to the above warranty, Heat Mat offer a lifetime extension to the above 15 year warranty on your earth shielded Combymat heating mat. To be covered by this extra warranty in addition to the above stipulations you must also:

- Register your product at www.heatmat.co.uk/warrantyregistration within 90 days of purchase.
- Be able to provide your proof of purchase of the system (a normal retail invoice/receipt is sufficient for this purpose).

- Ensure the system has been installed in accordance with Heat Mat's installation guidelines and is protected by a suitable RCD.
- Ensure that all installation work is compliant with current IEE wiring regulations and installations must comply with Part 'P' of the Building Regulations. You should retain your Part 'P' certificate as proof of this.

If the above stipulations have been followed, Heat Mat will provide a lifetime warranty once the original fifteen year warranty expires for the Combymat heater. This warranty runs for the life of the floor covering above the original installation. This warranty covers manufacturing defects in the Combymat heater supplied. Details and evidence of defects have to be presented to Heat Mat or an authorised UK or Ireland distributor for approval. When your warranty is invoked, your damaged product will either be repaired or replaced free of charge.

The repair or replacement of your system is the only remedy available to you under these warranties. None of the above warranties affect your statutory rights. Heat Mat Limited will in no event be liable for consequential losses or secondary charges, including but not restricted to the cost of replacing or repairing floor coverings, any costs associated with utility expenses or running costs, professional fees relating to trades peoples' subsequent work or any other damage caused to material items.

Heat Mat Limited,
Ashwyn Business Centre,
Marchants Way, Burgess Hill, RH15 8QY
Tel: 01444 247020 Fax: 01444 247121
www.heatmat.co.uk

Please complete and display at your distribution board.

Warning

This building is fitted with Heat Mat electric underfloor heating utilising a 240Vac supply.

Do NOT pierce the floors above the system with nails, screws or other fasteners.
(see installer diagram for heater positioning)

Do NOT expose the floor to thermal blocking or attempt to reduce the size of
the heated floor area.

(check suitability of floor covering with manufacturer & that furniture has 10mm (min) air void beneath it.)

In the event of flooding or when carrying out any repairs or alterations
disconnect the Under Floor Heating and contact your electrician or
Heat Mat for advice

Details of Installation:

Electricians Name:

Signature:

Company Name:

& Address:

Date:

Room with heating Installed: _____

Total Wattage of system: _____

Please list the product code and test results of each element
after installation (**compare to install guide for rated resistance**)

Product Code	Resistance Rating	Insulation Test Passed

Heat Mat Ltd - Tel No: 01444 247020

see www.heatmat.co.uk for more under floor heating solutions

This warranty card should be left with the thermostat user manual, Heat Mat system
installation guide and the installer's heater layout & wiring diagrams to meet IEE Wiring
regulations (17th Edition - section 753). These items should be permanently fixed near the
relevant distribution board.

Heat Mat
Underfloor Heating

Heat Mat Limited, Ashwyn Business Centre, Marchants Way, Burgess Hill. RH15 8QY

www.heatmat.co.uk

Reproduction of part or all of the contents of this fitting guide in any form is prohibited other than with the express
written permission of Heat Mat Limited.