

- Countdown from 30 secs. to 20 mins.
- Electronic Overload Protection
- Toggle switch for permanent light
- External push switch control
- Designed for use with TS35 DIN Rail

### Technical Data

<b>Rated Operating Voltage:</b>		230VAC	
<b>Voltage Tolerance:</b>		220-240VAC	
<b>Frequency Range:</b>		50-60Hz (common use)	
<b>Power Consumption:</b>		1W	
<b>Drive Method:</b>		Quartz Controlled Stepping Motor	
<b>Cycle:</b>		20 minutes	
<b>Time Precision:</b>		±3 sec./day at 22°C	
<b>LOAD</b>	<b>Contact Capacity:</b>	<b>Resistive Load</b>	16A, max. 3680W
		<b>Inductive Load</b>	230V, 4A cos φ =0.4
		<b>Energy Saving Lamp</b>	90W
		<b>LED Lamp &lt;2W</b>	20W
		<b>LED Lamp 2-8W</b>	55W
	<b>LED Lamp &gt;8W</b>	70W	
<b>Switch Construction:</b>		SPST	
<b>Manual ON/AUTO</b>		ON / AUTO switch	
<b>SETTING</b>	<b>Present Time Setting:</b>	Turn dial to set time	
	<b>Countdown:</b>	20 mins. - 30 secs.	
	<b>Accuracy:</b>	0-20 mins.: ±150 secs. 0-30 secs.: ±3 secs.	
<b>Protection Rating:</b>		IP20	
<b>Ambient Temperature:</b>		-10 to +55°C	
<b>Ambient Humidity:</b>		Max. 85% RH	
<b>Weight:</b>		Approx. 80g	

### Parts Identification & Wiring Diagram

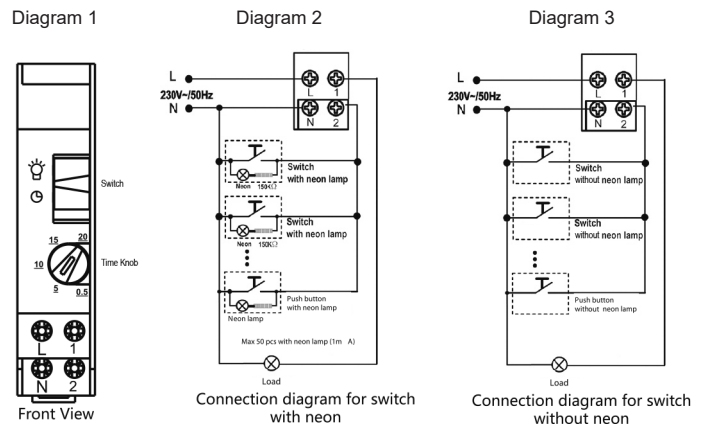

### Instructions for Use

This time switch has been designed specifically to switch off a particular circuit with a countdown period from 30 seconds to 20 minutes. Additionally, it can be used as a normal ON/OFF switch.





The SST-5-1C Staircase Time Switch allows for multiple switches to be connected, either with or without a neon lamp, in different locations for easier control.

#### 1. Mounting the Timer

Mount the timer in a suitable enclosure with TS35 (35mm) DIN Rail. Simply hook the timer on to the DIN Rail and push down until you hear a click. The timer is now attached to the DIN Rail. To remove the timer, pull down on the catch located on the bottom of the timer and pull the bottom of the timer toward you, then simply lift upwards.

#### 2. Connecting and Setting the Timer

Connect the wires as indicated in Diagram 2 for neon lamp operation, or Diagram 3 for operation without a neon lamp.

- Set the ON/AUTO switch to the  position for continuous operation.
- Turn the time dial to the desired  countdown time (from 30 seconds to 20 minutes).
- Set the switch to the  position for AUTO. This sets the time switch in to standby mode ready for operation.
- Countdown is initiated  according to the set time when the designated light switch is pressed.

Any number of lamps can be connected providing the total current does not exceed the maximum load of 150mA. There is no restriction to the number of connections without lamp.

#### NOTE:

When the timer countdown has been initiated, neither the pushbutton nor time dial are active.

The timer countdown can only be overridden by switching the ON/AUTO switch from  position and back to the  position.