

Product Code: QBW25

Description: BW Armoured Industrial Brass Glands 25mm (PK2)

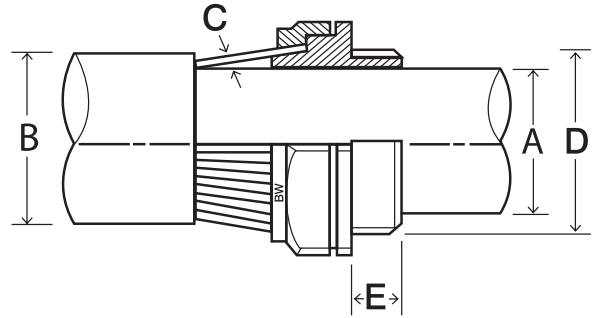

**Dimensions**

Cable Dia. Max. (A)	19.9mm
Cable Dia. Max. (B)	27.4mm
Armour Wire Dia. (C)	1.25/1.6mm
Gland Size (D)	25mm
Entry Thread (E)	10mm

**Materials**

Gland Body & Earth Tag: Brass  
 Locknut: Steel  
 Sleeve: PVC (Polyvinyl Chloride)

**General Information**

Ingress Protection	IP30
Temperature Rating	-80°C - +600°C

**Packaging Overview**

Polybag Of 2 Gland Kits

**Standards**

BS 6121-1:2005  
 BS EN 60529: 1992 + A2: 2013

**Directives**

RoHS 2: 2011/65/EU & RoHS 3: 2015/863/EU  
 REACH: 1907/2006/EU

