

**ceiling mounting – SF50 - SF100 - SL50 - CEQ - UC50 - SAS - CE40 - CM50XL**

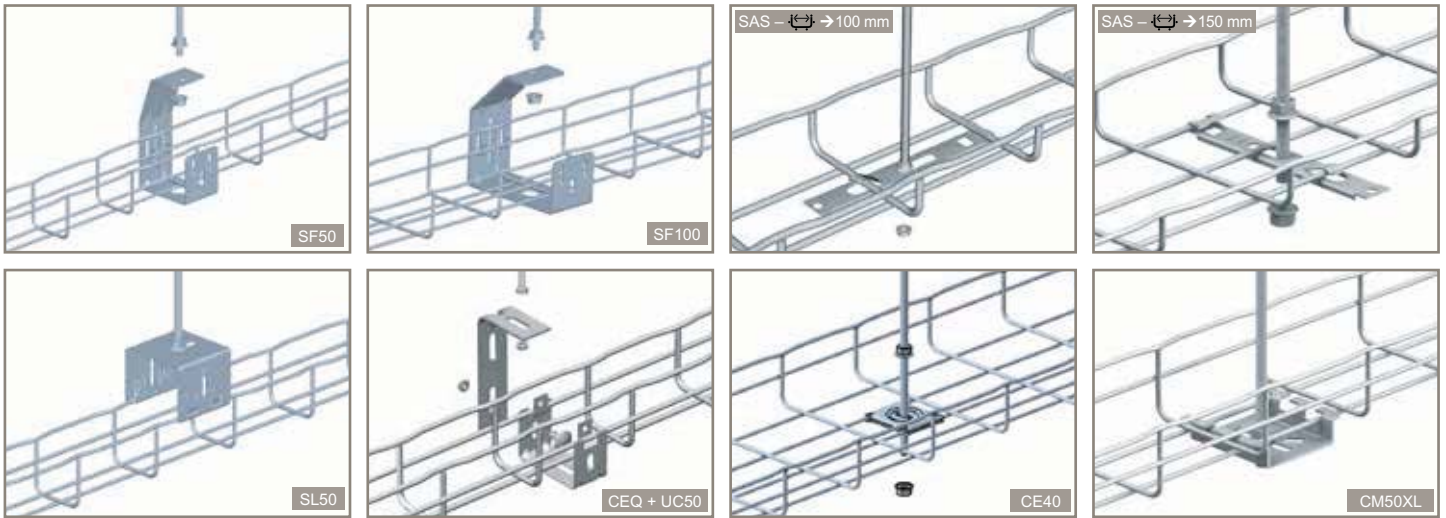

Dimensions and technical information p. 66-69

**NOTE : please use Cat. No. when placing your order**

Pack	Cat. Nos.		SF50 - SF100 – central hangers		
	<b>GS</b>	<b>GC</b>	$\downarrow \uparrow 30 \rightarrow 54 \text{ mm}$ $\leftarrow \rightarrow 50 \rightarrow 100 \text{ mm}$		
			For technical information, see p. 66		
1	CM586140	CM586143	SF50	30	73
1	CM586100	CM586103	SF100	26	134
	<b>304L</b>	<b>316L</b>			
1	-	CM586144	SF50	30	73
1	-	CM586104	SF100	26	134

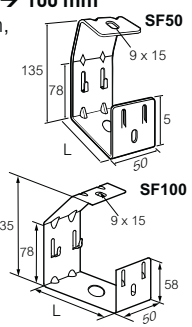

Pack	Cat. Nos.	SL50 – multifix base plate	
	<b>GS</b>	$\downarrow \uparrow 30 \rightarrow 54$ $\leftarrow \rightarrow 50 \text{ mm}$	
		For technical information, see p. 66	
1	CM585180	H mm	56
		$\downarrow \uparrow$ daN	150

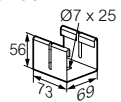

Pack	Cat. Nos.		CEQ – central hanger brackets	
	<b>GS</b>	<b>GC</b>	$\downarrow \uparrow 30 \rightarrow 54 \text{ mm}$ $\leftarrow \rightarrow 50 \text{ mm}$	
			For technical information, see p. 67	
1	CM557300	CM557303	$\downarrow \uparrow$ daN	12
	<b>304L</b>	<b>316L</b>		
1	-	CM557304		12

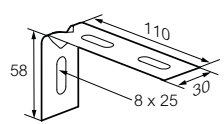

Pack	Cat. Nos.		UC50 – support cradles	
	<b>GS</b>	<b>GC</b>	$\downarrow \uparrow 30 \rightarrow 54 \text{ mm}$ $\leftarrow \rightarrow 50 \text{ mm}$	
			For technical information, see p. 67	
1	CM586040	CM586043	$\downarrow \uparrow$ daN	12
	<b>304L</b>	<b>316L</b>		
1	CM586048	CM586044		12

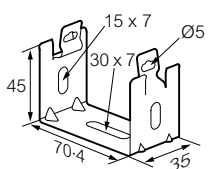

**NOTE : please use Cat. No. when placing your order**

Pack	Cat. Nos.		SAS – suspension hangers	
	<b>EZ</b>	<b>DC</b>	$\downarrow \uparrow 30 \rightarrow 54 \text{ mm}$ $\leftarrow \rightarrow 100 \rightarrow 150 \text{ mm}$	
			For technical information, see p. 68	
1	CM586031	CM586037	$\downarrow \uparrow$ daN	60

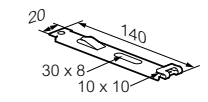

Pack	Cat. Nos.		CE40 – hold down clamps	
	<b>EZ</b>	<b>DC</b>	$\downarrow \uparrow 30 \rightarrow 54 \text{ mm}$ $\leftarrow \rightarrow 100 \rightarrow 200 \text{ mm}$	
			For technical information, see p. 69	
25	CM558051	CM558053	$\downarrow \uparrow$ daN	100
	<b>304L</b>	<b>316L</b>		
25	CM558058	CM558054		100

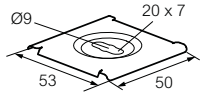

Pack	Cat. Nos.		CM50XL – universal mounting plates (large)	
	<b>GS</b>	<b>GC</b>	$\downarrow \uparrow 30 \rightarrow 54 \text{ mm}$ $\leftarrow \rightarrow 100 \rightarrow 200 \text{ mm}$	
			For technical information, see p. 69	
1	CM586130	CM586133	$\downarrow \uparrow$ daN	100
	<b>304L</b>	<b>316L</b>		
1	CM586138	CM586134	$\downarrow \uparrow$ daN	100

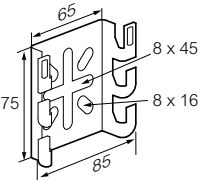

<b>Key :</b>	<b>EZ</b> Electrogalvanising after manufacture	<b>304L</b> Stainless steel 304L
	<b>GS</b> Pre-galvanised	<b>316L</b> Stainless steel 316L
	<b>GC</b> Hot dip galvanised after manufacture	
	<b>DC</b> Geomet	

For detailed information related to finishes, refer to p. 116-117

All dimensions (mm) are nominal