

# QuietAir QT120

Toilet, bathroom, utility room and kitchen (adjacent to hob)

## Key Features

- Axial fan
- Two speed ventilation up to 170 m<sup>3</sup>/hr\*
- Awarded Quiet Mark by Noise Abatement Society
- Quiet, noise level as low as 32 dB(A)
- Power consumption from only 10w
- Very low SFP of 0.24 W/l/s, IP45 rating
- Interval timer for routine auto extraction
- Long life ball-bearing motor 40,000 hours
- Integral flow straightener / backdraught flap
- Powerful extraction for longer ducts
- Suitable for installation anywhere in Zone 1 of bathrooms when installed with an RCD
- Install in a kitchen adjacent to the hob
- Complies with Building Regulations
- 3 year warranty



## QT120 range

The powerful performance QuietAir 120 is designed to provide extraction levels that exceed the requirements of the latest Building Regulations.

QuietAir, is a range of elegant, discreet axial fans that are supremely quiet. By using exceptionally low energy they help to reduce carbon emissions but also save on your electricity bill.

Operated by a range of control options including basic switching, timer, humidity and motion sensor control.

Room refresh (interval timer) enables automatic extraction at pre-set times if required.



## Models

<b>Basic</b>	Control by remote switch
<b>Timer</b>	Timer can be set to run on for 6,10,15 or 21 minutes
<b>Humidity Timer</b>	Humidity sensor can be set between 60 - 90% RH
<b>Motion Sensor Timer</b>	PIR sensor activates fan



## Technical Data

Specification	QuietAir QT120B	QuietAir QT120T	QuietAir QT120HT	QuietAir QT120MST
Air flow m <sup>3</sup> /hr*	150 / 170	150 / 170	150 / 170	150 / 170
Air flow l/sec*	42 / 47	42 / 47	42 / 47	42 / 47
Fan type	Axial	Axial	Axial	Axial
Controls	Basic	Timer	Humidity Timer	Motion Sensor Timer
Mounting	Wall / Ceiling	Wall / Ceiling	Wall / Ceiling	Wall / Ceiling
Sound pressure dB(A)@3m	32/36	32/36	32/36	32/36
Delay start (min)	No	2	2	No
Adjustable timer (min)	No	6,10,15,21	6,10,15,21	15
Adjustable humidity (%RH)	-	-	60 - 90	-
Interval timer, auto start (hrs)	-	0,8,12,24	-	-
Power watts	10/13	10/13	10/13	10/13
Amps	0.08/0.09	0.08/0.09	0.08/0.09	0.08/0.09
Specific Fan Power (SFP)	0.24	0.24	0.24	0.24
Building Regulations ADF	Yes	Yes	Yes	Yes
Duct Diameter (mm)	125	125	125	125
Voltage	230v / 1ph / 50-60Hz	230v / 1ph / 50-60Hz	230v / 1ph / 50-60Hz	230v / 1ph / 50-60Hz
Rating	IP45	IP45	IP45	IP45
Max ambient temperature	40°C	40°C	40°C	40°C
Weight (kg)	1.05	1.05	1.05	1.05
Dimensions (H x W x D) mm	176 x 176 x 155	176 x 176 x 155	176 x 176 x 155	176 x 176 x 155
Part No.	9041497	9041498	9041499	9041500*

\* 2nd Speed activated by remote switch

## Dimensions (mm)

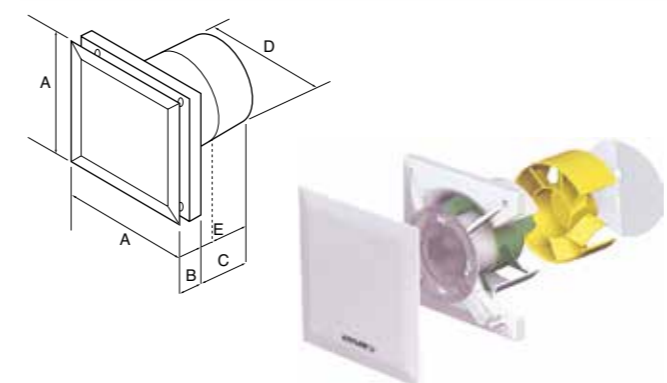

Model	A	B	C	D	E
QuietAir QT120	176	39	116	118	70

## Performance

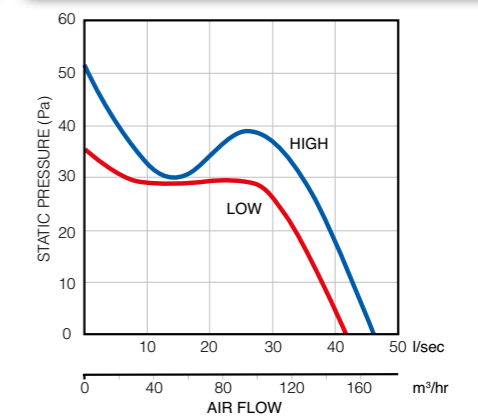

## Controls and Accessories

A range of accessories including flexible and rigid ducting kits, controls, switches and grilles are available.

See accessories for more details.

