

# QuietAir QT150

Kitchen



## Key Features

- Axial fan
- Two speed ventilation up to 260 m<sup>3</sup>/hr
- Quiet, noise level as low as 35 dB(A)
- Power consumption from only 6w
- Very low SFP of 0.09 W/l/s, IP45 rating
- Interval timer for routine auto extraction
- Long life ball-bearing motor 40,000 hours
- Integral flow straightener / backdraught flap
- Powerful extraction for longer ducts
- Variable speed control version
- Install in a kitchen / light commercial
- Complies with Building Regulations
- 3 year warranty



## QT150 range

The powerful performance QuietAir 150 is designed to provide extraction levels that exceed the requirements of the latest Building Regulations. Ideal for kitchens and larger rooms.

QuietAir, is a range of elegant, discreet axial fans that are supremely quiet. By using exceptionally low energy they help to reduce carbon emissions but also save on your electricity bill.

Operated by a range of control options including basic switching, timer, humidity and variable speed control.

Room refresh (interval timer) enables automatic extraction at pre-set times if required.



## Models

<b>Basic</b>	Control by remote switch
<b>Timer</b>	Timer can be set to run on for 6,10,15 or 21 minutes
<b>Humidity Timer</b>	Humidity sensor can be set between 60 - 90% RH
<b>Variable speed</b>	Controlled by remote switch



## Technical Data

Specification	QuietAir QT150B	QuietAir QT150T	QuietAir QT150HT	QuietAir QT150VS
Air flow m <sup>3</sup> /hr*	220 / 260	220 / 260	220 / 260	50 - 260
Air flow l/sec*	61 / 72	61 / 72	61 / 72	13 - 72
Fan type	Axial	Axial	Axial	Axial
Controls	Basic	Timer	Humidity Timer	Variable Speed
Mounting	Wall / Ceiling	Wall / Ceiling	Wall / Ceiling	Wall / Ceiling
Sound pressure dB(A)@3m	35/39	35/39	35/39	35/39
Delay start (sec's)	No	0,45,90,120	0,45,90,120	No
Adjustable timer (mins)	No	6,10,15,21	6,10,15,21	No
Adjustable humidity (%RH)	-	-	60 - 90	-
Interval timer, auto start (hrs)	-	0,8,12,24	-	-
Power watts	6/10	6/10	6/10	6/10
Amps	0.07/0.12	0.07/0.12	0.07/0.12	0.07/0.12
Specific Fan Power (SFP)	0.09/0.13	0.09/0.13	0.09/0.13	0.09/0.13
Building Regulations ADF	Yes	Yes	Yes	Yes
Duct Diameter (mm)	145	145	145	145
Voltage	230v / 1ph / 50Hz	230v / 1ph / 50Hz	230v / 1ph / 50Hz	230v / 1ph / 50Hz
Rating	IP45	IP45	IP45	IP45
Max ambient temperature	40°C	40°C	40°C	40°C
Weight (kg)	1.2	1.2	1.2	1.2
Dimensions (H x W x D) mm	210 x 210 x 190	210 x 210 x 190	210 x 210 x 190	210 x 210 x 190
Part No.	90000454	90000455	90000456	90000458
Variable speed controller				90000514*

\* refer to accessories section.

## Dimensions (mm)

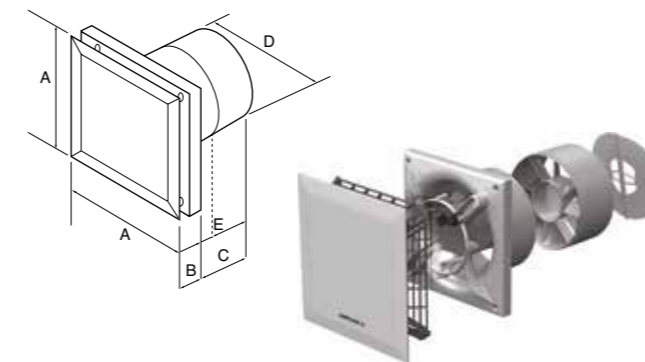

Model	A	B	C	D	E
QuietAir QT150	210	48	142	145	76

## Performance

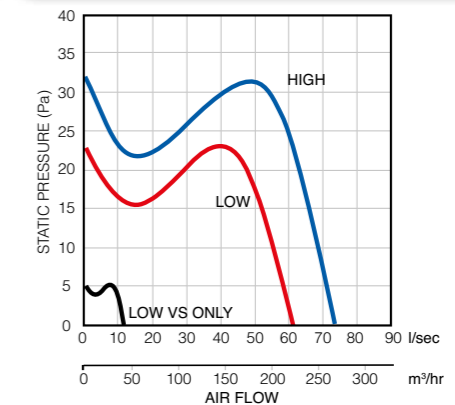

## Controls and Accessories

A range of accessories including flexible and rigid ducting kits, controls, switches and grilles are available.

See accessories for more details.

