

QuietAir QT100

Toilet, bathroom and en-suite ventilation



Key Features

- Axial fan
- Two speed ventilation up to 90 m³/hr*
- Awarded Quiet Mark by Noise Abatement Society
- Extremely quiet, noise levels as low as 25 dB(A)
- Power consumption from only 5w
- Interval timer for routine auto extraction
- Very low SFP of 0.24 W/l/s
- Long life ball-bearing motor 40,000 hours
- Integral flow straightener / backdraught flap
- Powerful extraction for longer ducts
- Suitable for installation anywhere in Zone 1 of bathrooms when installed with an RCD
- IP45 rating
- Complies with Building Regulations
- 3 year warranty



QT100 range

The whisper quiet QuietAir QT100 is designed to provide powerful extraction levels that exceed the requirements of the latest Building Regulations.

The QuietAir QT100 is the quietest fan available complying with Building Regulations "Installed Performance" requirements when ducted.

QuietAir is a range of elegant, discreet axial fans that are extremely quiet with various control options that activate the fan only when needed – remote switching,

timer, humidity timer and motion sensor with timer. By using exceptionally low energy this helps to reduce carbon emissions and also save on your energy bills. It has a high efficiency impeller for extraction through up to 12m of rigid ducting and still complies with the Building Regulations.

Room refresh (interval timer) enables automatic extraction at pre-set times if required.



Models

Basic	Control by remote switch
Timer	Timer can be set to run on for 6,10,15 or 21 minutes
Humidity Timer	Humidity sensor can be set between 60 - 90% RH
Motion Sensor Timer	PIR sensor activates fan



Technical Data

Specification	QuietAir QT100B	QuietAir QT100T	QuietAir QT100HT	QuietAir QT100MST
Air flow m ³ /hr*	75 / 90	75 / 90	75 / 90	75 / 90
Air flow l/sec*	21 / 25	21 / 25	21 / 25	21 / 25
Fan type	Axial	Axial	Axial	Axial
Controls	Basic	Timer	Humidity Timer	Motion Sensor Timer
Mounting	Wall / Ceiling	Wall / Ceiling	Wall / Ceiling	Wall / Ceiling
Sound pressure dB(A)@3m	25/30	25/30	25/30	25/30
Delay start (min)	No	2	2	No
Adjustable timer (min)	No	6,10,15,21	6,10,15,21	15
Adjustable humidity (%RH)			60 - 90	
Interval timer, auto start (hrs)		0,8,12,24		
Power watts	5/9	5/9	5/9	5/9
Amps	0.04/0.06	0.04/0.06	0.04/0.06	0.04/0.06
Specific Fan Power (SFP)	0.24	0.24	0.24	0.24
Building Regulations ADF	Yes	Yes	Yes	Yes
Duct Diameter (mm)	100	100	100	100
Voltage	230v / 1ph / 50-60Hz	230v / 1ph / 50-60Hz	230v / 1ph / 50-60Hz	230v / 1ph / 50-60Hz
Rating	IP45	IP45	IP45	IP45
Max ambient temperature	40°C	40°C	40°C	40°C
Weight (kg)	0.8	0.8	0.8	0.8
Dimensions (H x W x D) mm	147 x 147 x 131	147 x 147 x 131	147 x 147 x 131	147 x 147 x 131
Part No.	9041259	9041260	9041261	9041262

* 2nd Speed activated by remote switch

Dimensions (mm)

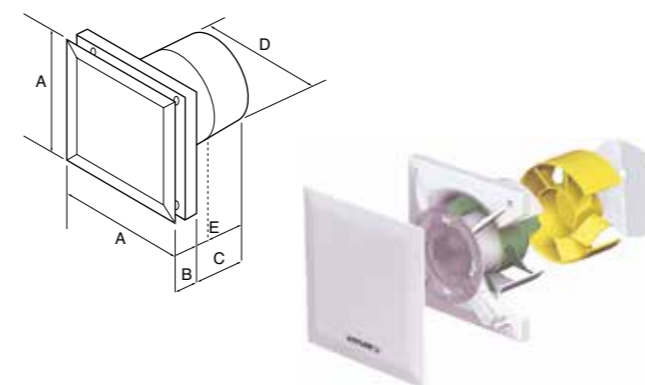

Model	A	B	C	D	E
QuietAir QT100	147	35	96	98	52

Performance

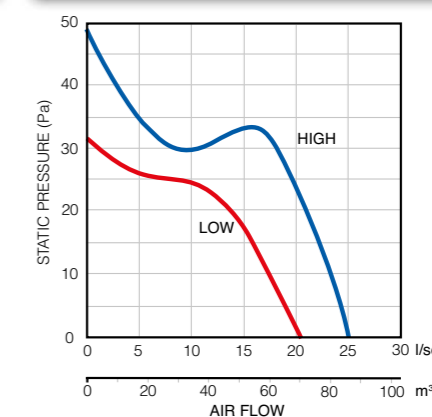

Controls and Accessories

A range of accessories including flexible and rigid ducting kits, controls, switches and grilles are available.

See accessories for more details.

