

8MWEURO2

Sheer | SHEER RANGE | EuroFix Apertured Plates complete with Fixing Grid

Item Image



Wiring



Dimensions

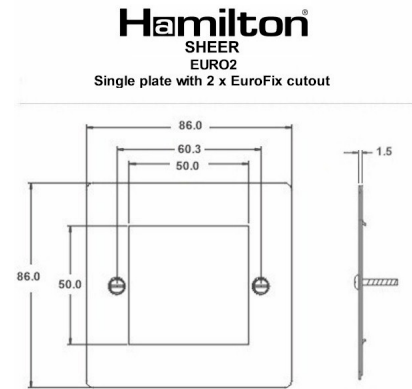

Primary Range	Sheer	
Insert Type	2 gang EuroFix 50x50mm Apertured Plate with Grid	
Insert Colour	No Insert Colour	
EAN13 Barcode	5017504068004	
Commodity Code	74199100	
Luckins TSI	404398211	
Dimensions(Nominal)	Single: Height = 86.0mm Width = 86.0mm Depth = 1.5mm	
Weight	96 GR	
Switched Poles	N/A	
Current Rating	Insert Specific	
Voltage	Insert Specific	
Maximum Load	Insert Specific	
IP Rating	N/A	
Contact Gap Minimum	N/A	
Earth Terminal Capacity 1	5x1mm ²	
Earth Terminal Capacity 2	4x1.5mm ²	
Earth Terminal Capacity 3	3x2.5mm ²	
Earth Terminal Capacity 4	1x4mm ² Multi-strand	
Earth Terminal Capacity 5	1x6mm ²	
Product Class 1	Face plate must be earthed	
Recommended Location	Internal Use Only	
Maximum Installation Altitude	2000m	
Standard/Approval	N/A	
Additional Notes	See EuroFix for a full range of inserts. Plates must be Earthed via the Earth Tag.	
All products listed conform to current British or European standard and the product information is correct at the time of going to press.	All accessories are manufactured under an accredited BS EN ISO 9001 : 2015 Quality Management System.	It is the policy of the company to improve products as part of our development programme. Therefore, we reserve the right to alter designs and dimensions without prior notice.

8MWEURO2

Sheer | SHEER RANGE | EuroFix Apertured Plates complete with Fixing Grid

Illustrations and diagrams are reproduced within the limitations of reproduction and printing process and are not binding.

Due to manufacturing processes we cannot guarantee an exact colour match and shadings of of certain finishes.

Correct as at 30 July 2021 02:13 PM
E&OE

R Hamilton & Co Ltd, Unit 10 Carrick Business Centre, 4-5 Bonville Road,
Brislington, Bristol, BS4 5NZ

T: +44 (0)1747 860088 F: +44 (0)1179 710414

E: info@hamilton-litestat.com www.hamilton-litestat.com

Registered Office 1 Rushmills, Bedford Road, Northampton NN4 7YB

Registered in London No. 941624 VAT Registration No. 222 6607 84

