

Product Code: Q-04205

Description: M5 x 50mm Spring Toggles

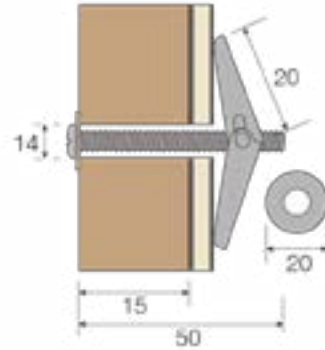

Dimensions

Thread Length (mm)	50
Thread Size	M5
Drill Size (mm)	14
Maximum Fixture Thickness (mm)	15
Arm Length (mm)	20
Washer Outer Diameter (mm)	20

General Information

Head Type	Slotted Pan Head
-----------	------------------

Materials

Material:	Zinc Plated Carbon Steel
-----------	--------------------------

Additional Information

<p>Ideal solution for fixing items such as light fittings and smoke alarms to cavity walls and low structural strength ceilings</p>

