



AlarmSense® Installation Guide

General

AlarmSense® is a range of conventional detection and alarm products designed to be connected to the same pair of supply wires. It is not compatible with other ranges of detectors and must be used with AlarmSense compatible control equipment.

The AlarmSense Sounder Base, Sounder Beacon Base and Alarm Relay referred to in this guide incorporate priority/non-priority switching. If this enhanced feature is required, please check with the control equipment manufacturer that the feature is accessible.

The basic functions of all these devices are compatible with all AlarmSense panels and are backwards compatible with all previous AlarmSense devices.

The products are not suitable for outdoor use. Insulation checks on cabling must be conducted prior to connection of AlarmSense devices.

AlarmSense Base

Wiring connections to the AlarmSense base, part no 45681-244, are shown in **Fig 6**.

The incoming and outgoing cables are connected to the same terminals, L1 IN (+ve Line) and L2 (-ve Line). A remote indicator can be connected to each base, -R (Remote LED +ve) and L2 (Remote LED -ve).

AlarmSense Sounder Base

The AlarmSense Sounder Base, part no 45681-510, is an integrated base and sounder. Each sounder base has a switch to set it to either a priority sounder or a non-priority sounder.

Note: the Sounder Base is factory set as a priority sounder.

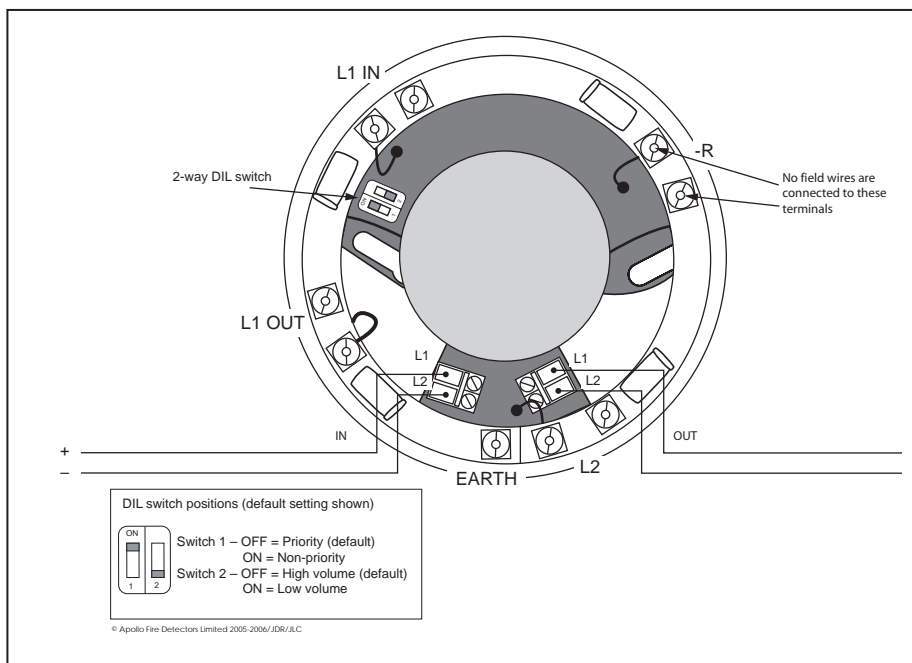

Fig 1 Sounder/Sounder Beacon Base

AlarmSense Sounder Beacon Base

The AlarmSense Sounder Beacon Base, part no 45681-509, combines a sounder with a beacon and a detector base in one unit. The beacon is activated whenever the sounder is active and cannot be controlled separately.

Note: the Sounder Beacon Base is factory set as a priority sounder.

Installation

1. Bring incoming and outgoing cable tails through the aperture in the sounder. Screw the sounder to a mounting box or directly to the mounting surface as required.
2. Connect the incoming two cables to +IN (L1) and –IN (L2) and outgoing cables to –OUT (L2) and +OUT (L1).
3. The priority/non-priority feature and volume are set by means of the DIL switch, see Fig 1.

Note: This feature is not available on all AlarmSense control panels. Please check with control panel manufacturer.

Apollo recommends that when a heat detector is attached to a sounder base/sounder beacon base that the sounder is set as a 'priority' sounder.

For stand-alone sounders or sounder beacons, fitted with either a white cap, part no. 45681-294 or red cap, part no 45681-295

1. Follow the steps 1—3 above.
2. A wire link (not supplied) is required between L1 IN and L1 OUT to disable the head removal signal.
3. When using the sounder base or sounder beacon base in stand-alone mode, the non-priority feature is not available.

Technical Data: AlarmSense System

Operating Voltage

Detectors and MCP	9-33V
Sounders (off)	9-15V
Sounders (on)	18-33V

Sounder Output

High tone setting	maximum volume 87dB(A)
Low tone setting	volume nominally 70dB(A)

SPL polar plot data is available in document PP2203 available on request.

Troubleshooting

Before investigating individual units for faults, ensure the system wiring is fault free.

Fault Finding

Problem	Possible Cause
Control panel reports zone fault	EOL resistor not fitted or incorrect value Detector removed Incorrect zone wiring Incompatible control panel
Control panel reports alarm	Incorrect EOL resistor Detector or MCP in alarm state
Sounder fails to operate	Incorrect wiring Sounders disabled at control panel
Sounder operates continuously MCP does not activate alarm	Incompatible control panel Polarity reversed MCP disabled at panel

AlarmSense Alarm Relay

Part no 55000-835 is a relay used to switch and monitor conventional sounders and beacons on an AlarmSense zone. The relay can be set to priority or non-priority by means of a DIL switch.

Note: the Alarm Relay is factory set to its priority setting.

Installation

If connecting conventional sounders and beacons to an AlarmSense zone, the alarm relay has to be placed first in the zone (see Fig 7).

Note: the Alarm Relay has to be mounted in a suitable enclosure rated at IP20.

1. Connect negative to L2 and the 12/24V connection to L1
2. Connect between L1 and N/O1
3. Connect L2 to N/O2
4. Connect N/C1 to N/O2
5. Connect N/O1 to N/C2
6. Positive zone wiring connects to COM 2 and the negative to COM 1.
7. Connect end-of-line supplied by the panel manufacturer between COM 1 and COM 2. (See Fig 6).
8. Set the priority/non-priority feature using the DIL switch.

Note: the Alarm Relay will reset on a 'silence alarms' signal from the control panel.

AlarmSense Manual Call Point

The AlarmSense Manual Call Point (EN54), part no. 55100-894, is supplied with a backbox for surface mounting. The call point is 'Type A' meaning it is suitable for indoor use only. For flush mounting, a standard electrical outlet box with a minimum depth of 20mm is required.

Installation – General

The installation must conform to BS5839: Part 1 (or applicable local codes).

Warning: AlarmSense call points are polarity sensitive.

Installation

1. Fit the backbox (Fig 2) to the wall.
2. Run the cables into the backbox and connect them to the terminal blocks as shown in Fig 3. Ensure that functional earth/screen continuity is maintained. Screens should be connected to the yellow terminal block marked 1–4 on the black PCB cover.
3. If a continuity test is to be done, it should be carried out before securing the call point to the backbox (step 4). Insert the continuity links supplied with the backbox (Fig 4) into the terminal blocks before testing. After testing for continuity remove the connectors and store for re-use.
4. Unlock the small front cover by inserting the forked key and pushing it home. Pull the cover down and towards you and remove the deformable element. Connect the terminal blocks as shown in Fig 3, secure the call point to the backbox and refit the deformable element as required. Finally, replace the front cover in the reverse order in which it was removed and push it up until it locks.

Transparent Hinged Cover (flip lid)

To provide additional protection against accidental operation of call points, a transparent hinged cover with locking tag, part no. 26729-152 is available, which can be fitted to the manual call points included in this guide. AlarmSense glasses are also available, part no. 39117-747.

Please note that once a manual call point is fitted with such a lid it no longer complies with BS5839: Part 2. For non-UK installations, check compliance with the appropriate authority.

Commissioning

Test each MCP using the test key provided. Ensure the control panel enters the alarm state and the LED illuminates.

Wiring Details

All wiring terminals accept solid or stranded cables up to 2.5mm².

Maximum Current Consumption at 15V

quiescent	<50µA at 15V
alarm current at 2–4.5V	<1.5mA
at 7.5–15V	25±2mA
at 18–24V	<1.5mA

LED Indicator

- ⊙ Illuminated red when call point is operated

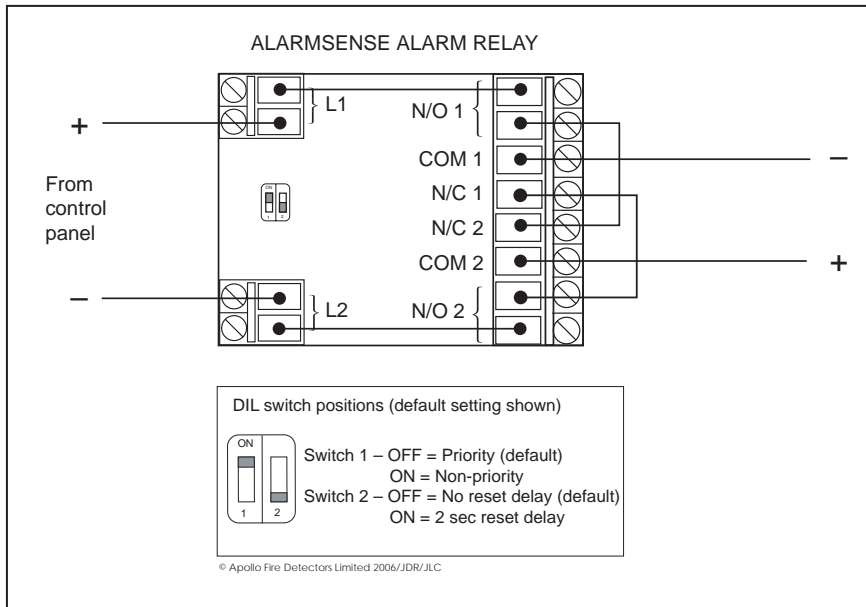

Fig 7 AlarmSense Alarm Relay wiring

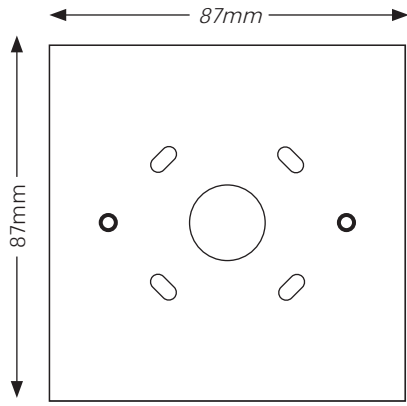

Fig 2 Backbox

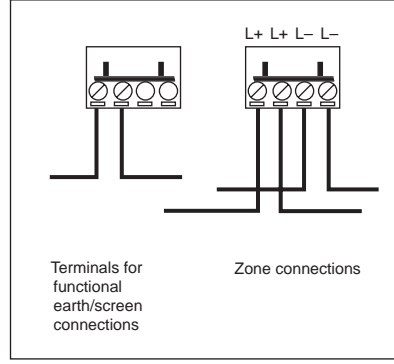

Fig 3 Terminal block connections

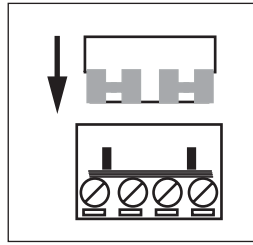

Fig 4 Continuity link

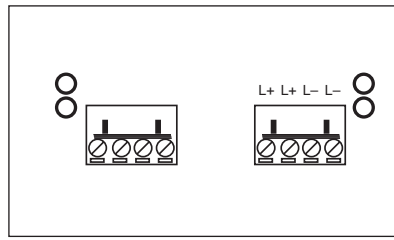

Fig 5 Terminal blocks fitted

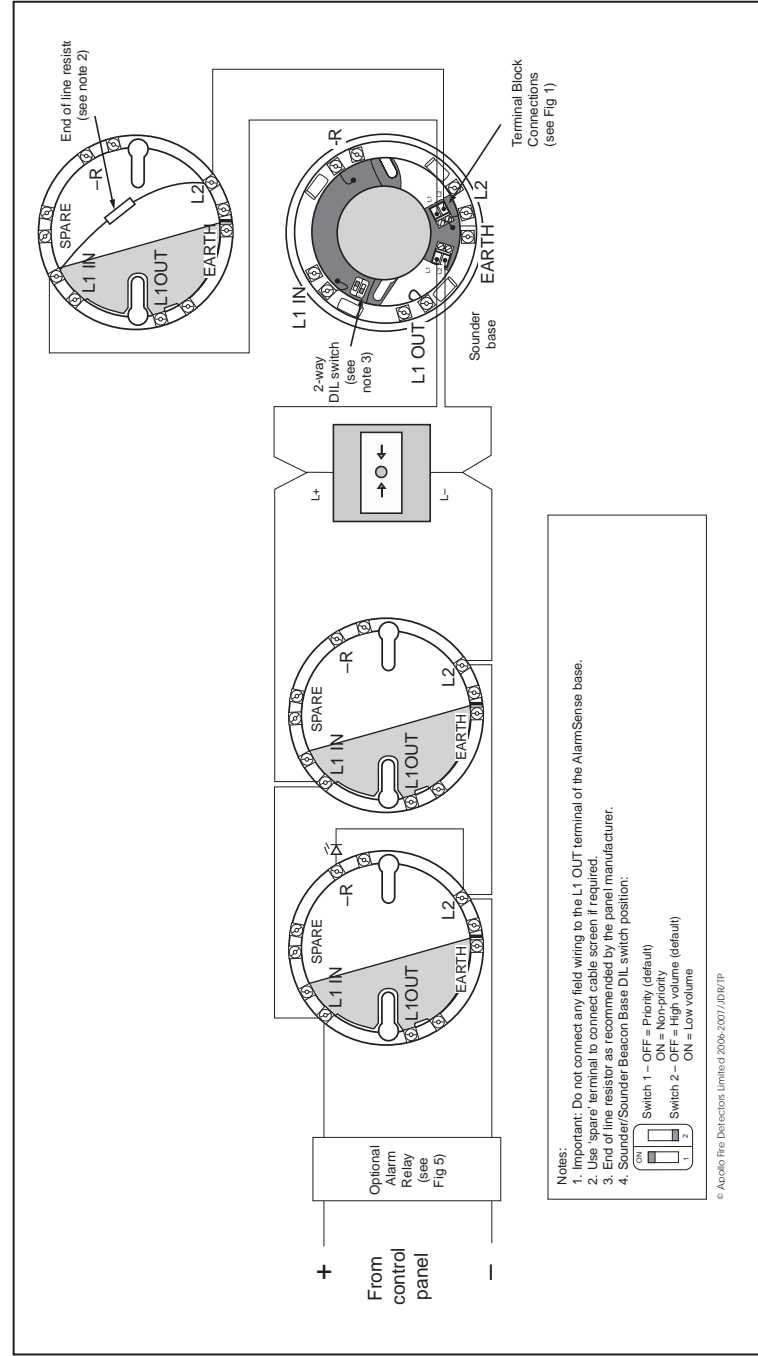

Fig 6 Schematic wiring diagram of an AlarmSense zone