

Congratulations on the purchase of your high gain wideband aerial. This aerial has been manufactured to the standard required to get the best reception of digital terrestrial TV services (DTT). This aerial is also 4G ready - the design restricts bandwidth to prevent interference & channel loss on your TV caused by signals from 4G transmitters. If the aerial is to be used for DTT reception check before installation at www.dtg.org.uk/industry/coverage.html to confirm that your home is in a coverage area and to find where your local transmitter is. For optimum results install the aerial using double screened digital coax cable and screened coax outlets.

Main Features

- Wideband – suitable for all UK TV reception areas, covering frequency range 460-790MHz
- Receives digital TV signals
- Suited for moderate and strong signal strength areas

The aerial requires some assembly - please read these instructions carefully before beginning.

A. Fitting the dipole assembly

The dipole clips onto the central boom. Ensure that the cable exit hole (from the terminal box) faces the rear of the aerial and that the locating stud fits into the locating hole on the boom as shown in Fig. 1.

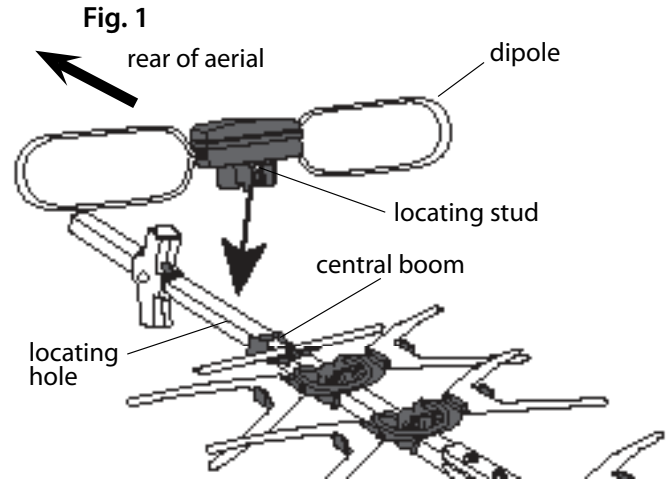

B. Rotating aerial elements and central boom assembly

1. Rotate the elements about the central fixing clip until they 'snap' into an upright position as shown in Fig. 2.
2. The central boom comes in two sections using the bracket supplied and the holes drilled in the boom sections join these two sections as shown in Fig. 3.

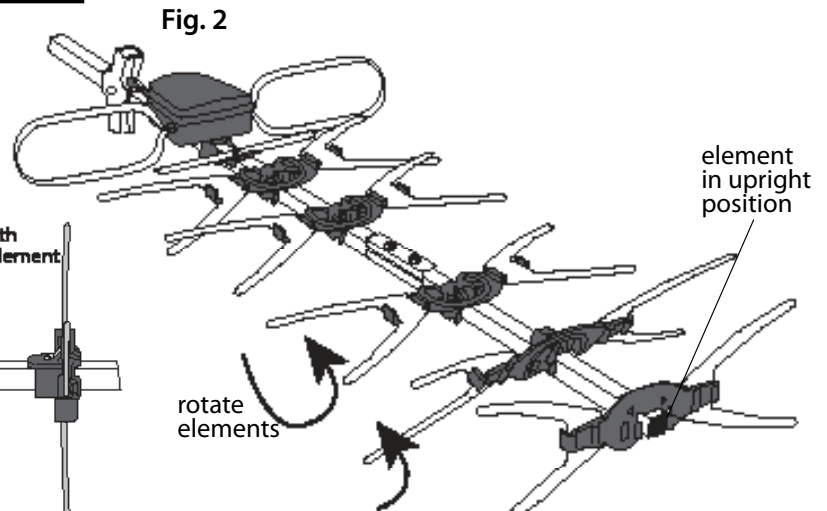
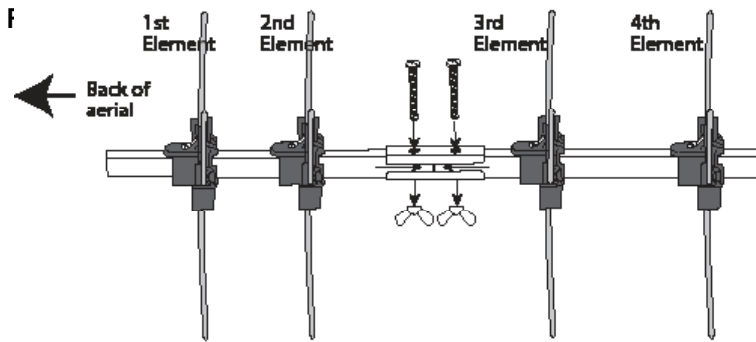

C. Fitting the reflectors

1. Using the reflector clamps, screw and large wing nut, fix the reflector assemblies to the main aerial boom as shown in Fig. 4 and 5.
2. Check that the reflector clamp tabs locate in the holes of the reflector boom sections and that the wing nut is tight, see Fig. 5.
3. Ensure that the reflector elements are facing towards the front of the aerial (convex surface forward).

Fig. 4

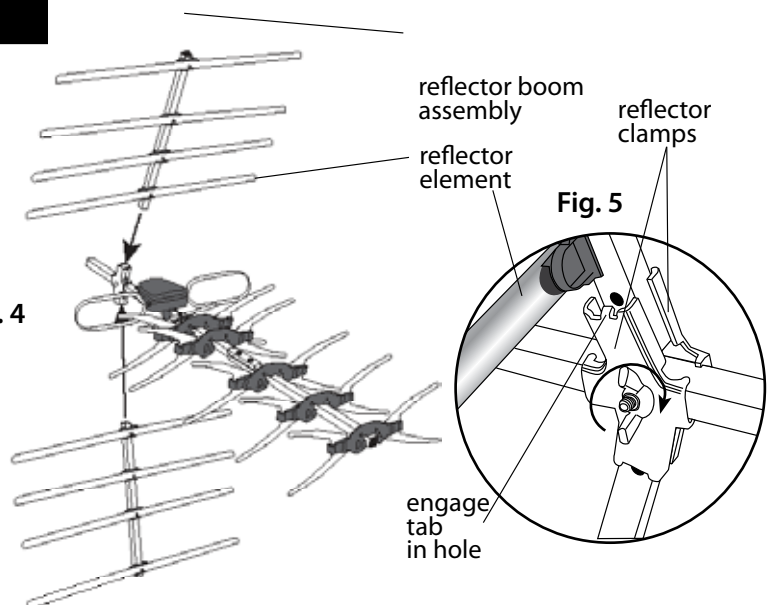

Please Note: Coaxial cable, mountings and masts are not supplied with this aerial. You will need to select these from the range available according to the specific requirements of your installation. The quality of the coaxial cable used is as important as the quality of the aerial and you should make sure that if it is not specifically marked as suitable for digital TV it is of the same quality as that used for digital satellite installations.

D. Connecting coax cable

1. Before preparing and stripping the cable ready for connection, feed the coax cable through the hole in the terminal cover.
2. Prepare cable as shown in Fig. 6
3. Feed prepared cable through the braid clamp and thread the centre wire through the hole in the central terminal as shown in Fig. 7.
4. Clamp the cable braid securely first, then tighten the screw on the central terminal. Trim any stray braid that might come into contact with the centre wire or central terminal.
5. Replace terminal cover carefully and securely making sure that the cable is not trapped or kinked.

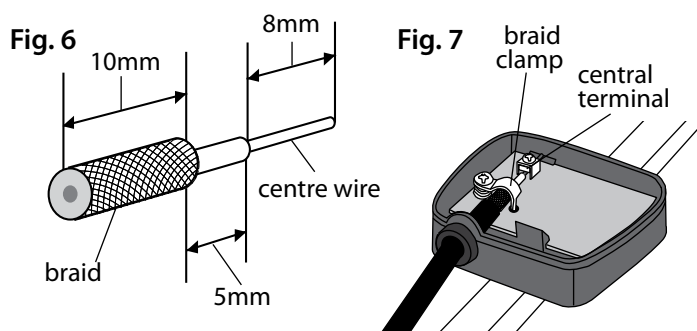

E. Coax cable routing

For optimum performance it is very important that the coax cable should be routed as shown in Fig. 8.

DO NOT ALLOW THE CABLE TO TOUCH THE AERIAL BOOM AT ANY POINT.

PVC insulation tape can be used as shown to hold the cable in place.

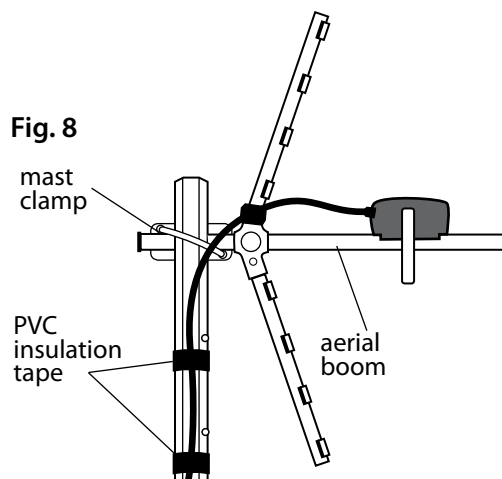

F. Fixing to a mast

For best results the aerial should be mounted on an outdoor aerial mast and pointed in the direction of the nearest transmitter* making sure it is in a position where the transmitter signal will not be obstructed by nearby trees and buildings. If you are in any doubt about the direction in which the aerial should be pointing or the orientation of the aerial (horizontal for main transmitter, vertical for relay transmitter) check your neighbours' aerials.

If mounting on an existing mast check that the mast is in good condition and firmly fixed.

1. Using the clamp supplied fix the aerial to the mast - see Fig. 8 & 9.
2. After the aerial direction has been fine tuned for best reception tighten the bolts firmly until the aerial is securely fixed to the mast.

Please note that this aerial can also be loft mounted.

CAUTION: When mounting the assembled aerial, always observe safety precautions and use the correct equipment. Unless you are competent in the use of ladders and other access equipment, do not work outdoors at roof height. If in any doubt, refer to a qualified aerial installer.

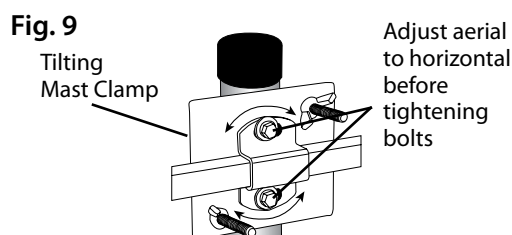

PLEASE NOTE: A coax plug is not included with this aerial. If you need to fit one please follow the wiring instructions shown below.

Box contents

- 1x Central boom: assembly square aluminium (L) approx 780mm with 5x 'X' type elements assembled
- 2x Reflector booms: Square aluminium (L) approx 330mm with 8x Reflector elements: Curved aluminium (L) approx 500mm
- 1x Bow tie shaped dipole and printed circuit balun
- 1x Tilting mast clamp

Troubleshooting

No picture: Check all connections from aerial to TV.

Poor picture: Check all connections from aerial to TV.

Check aerial is properly aligned to the correct transmitter.

If the aerial has been loft mounted try mounting outside.

Make sure new digital coax cable has been used throughout the installation.

Check the transmitter signal is not obstructed by nearby trees or buildings.

If in a very weak signal area or for long cable runs, installing a masthead amplifier will improve the signal.

If in a strong signal area the signal strength may need to be reduced by fitting an attenuator.

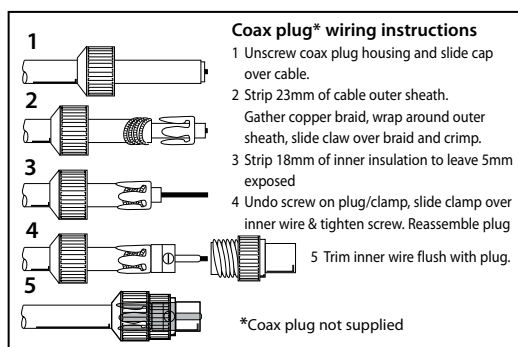

Other Useful Websites for Digital Advice:

*To confirm that your home is in a coverage area, to find out what DTT channels should be available locally and to find out where your nearest transmitter is (distance and compass bearing) visit: **Digital UK Website:** www.dtg.org.uk/industry/coverage.html

Customer Careline: 08457 573 479

Local rate UK only

Technical Website: www.philex.com/support

E-mail Support: technical@philex.com