

CHANNEL

SAFETY SYSTEMS

Glade



LED emergency downlights from Channel Safety Systems

CHANNEL SAFETY SYSTEMS

Petersfield Business Park
Bedford Road
Petersfield
Hampshire
GU32 3QA

t: 0845 884 7000

f: 0845 884 6000

e: sales@channelsafety.co.uk

w: www.channelsafety.co.uk

INSTRUCTION MANUAL

INSTALLATION

The Glade 1 watt non-maintained and 5 watt maintained are compact fittings that utilise the latest LED technology. This ensures an environmentally friendly emergency downlight.

- 1W non-maintained and 5W maintained versions available
- Line Voltage: 220 - 240 V AC, 50 ~ 60Hz
- Lamp Type: Flux White LED
- 3 hour Emergency Lighting Duration
- Meets BS EN 60598-2-22 and other relevant standards

PARAMETER	VALUE			UNIT
	MIN	TYP	MAX	
Line Voltage	220		240	[Vac]
Line Frequency		50		[Hz]
Standby Current		35		[mA]
Battery Charging Current			100	[mA]
LED Drive Current		100		[mA]
Environmental Temperature Range	0		35	[°C]
Case Temperature (max)			50	[°C]
Battery Nominal Voltage		3.6		[V]
Battery Nominal Capacity		1500		[mAh]
Battery Nominal Capacity		4500		[mAh]
Hole size required (nominal)	36		38	mm
Hole size required (nominal)	70		75	mm

INSTALLATION

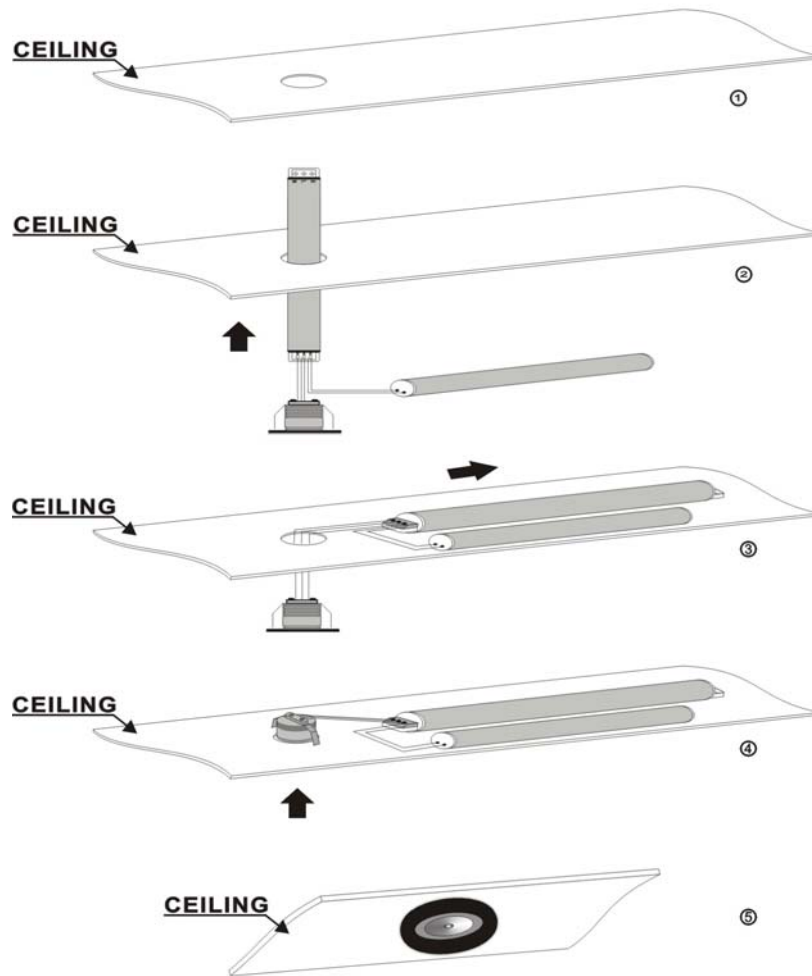

The 5w unit may be installed in the non maintained mode by omitting the 'Lsw' input.

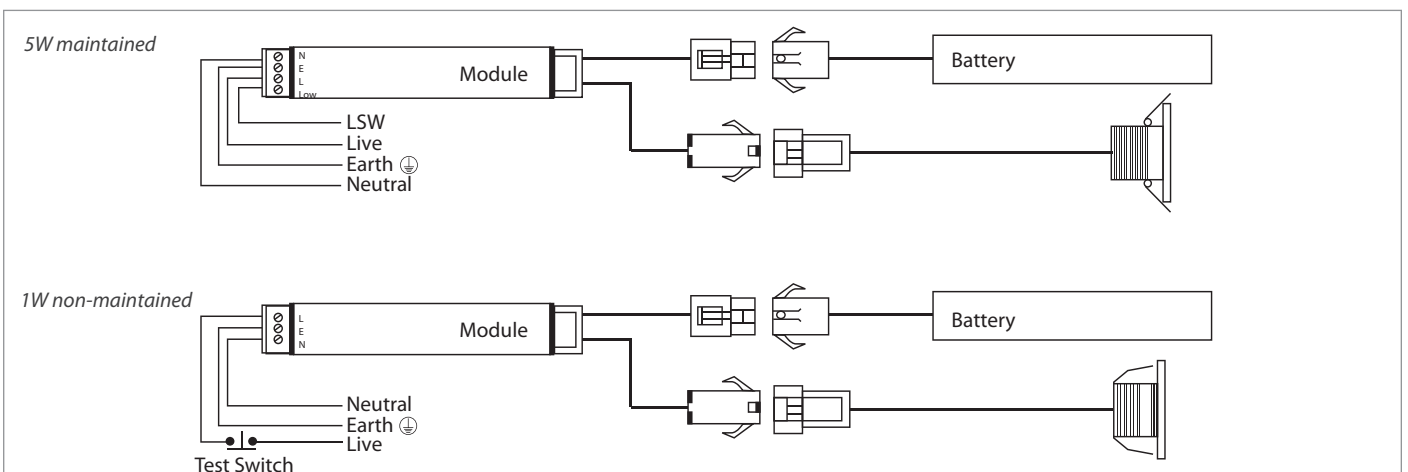

CHANNEL SAFETY SYSTEMS

Petersfield Business Park
Bedford Road
Petersfield
Hampshire
GU32 3QA

t: 0845 884 7000

f: 0845 884 6000

e: sales@channelsafety.co.uk

w: www.channelsafety.co.uk