

# BIS Strut Rail Beam Clamp

to make Strut rail fabrications

(H 36 05)

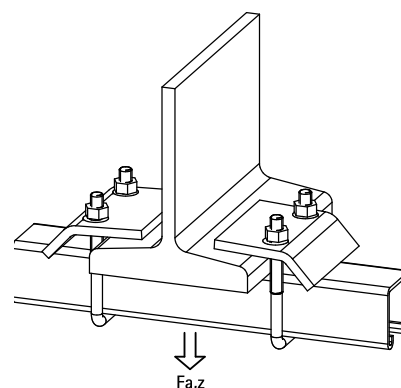

## Features and benefits

- for a solid fixing to steel construction without the need for welding or drilling
- material: steel 1.0332
- hot dip galvanized
- always use 2 beam clamps per fixing

Part No.	A (mm)	G	L	B (mm)	H (mm)	s (mm)	SW1 (mm)	For Rail	Fa,z (N)	Pack 1
6658 1 711	20	M10	69 mm	80	90	6.0	17	Strut 41x21 + 41x41 + 41x21D	5,700	25
6658 1 721	20	M10	69 mm	80	130	6.0	17	Strut 41x62 + 41x82 + 41x41D	5,700	25

*Also available in stainless steel 1.4401 (AISI 316).*

