

# BIS RapidRail® Wall Plate

fixing to wall

(G 15 05)



661 3 200

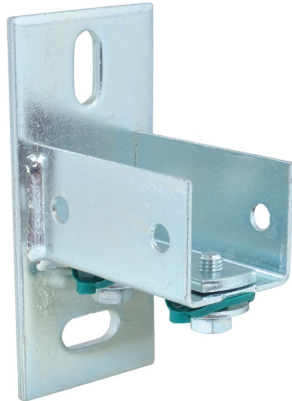

661 3 235

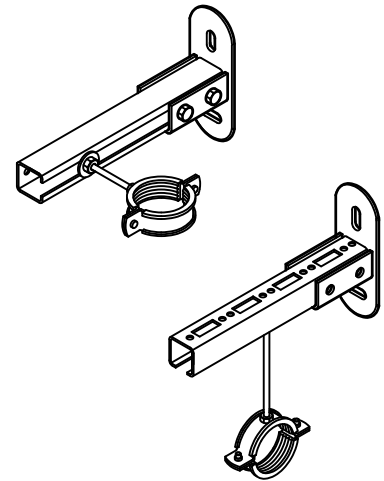

## Features and benefits

- U-profile welded on wall plate
- for wall fixing of rail
- rail can be fixed with slot downwards or sideways
- Part No. 661 3 200: suitable for WM0, 1, 15, 2, 30
- Part No. 661 3 235: suitable for WM35
- slots at 90° to each other to simplify fixing
- CO<sub>2</sub> welded
- with pre-assembled BIS RapidRail® Sliding nut(s) for a quick fixing, and retains assembly in place before final tightening
- material: metal parts made of steel 1.0332; spring(s) made of POM (polyoxymethylene), green
- zinc plated

Part No.	T (max.) (Nm)	For Rail	Pack 1
661 3 200	15.0	WM0 - 30	25
661 3 235	15.0	WM35	25

