

AXIAL FANS WITH ULTRA-FLAT GRILLE TO EXPEL THE AIR OUTSIDE OR INTO SHORT DUCTS. FOR WALL AND CEILING INSTALLATION

## Punto Filo Range

- The front grille of just 17 mm and the roundness of the four sides makes the appliance “virtually” invisible.
- 4 diameters 90-100-120-150, standard, timer, long life versions.
- Data, Safety and Performance Certified by IMQ Performance CE Mark.
- Extremely easy installation and maintenance. Fitted with just 1 screw, supplied in the box.
- Virtually silent thanks to a new impeller that permits very limited noise levels with high performance.
- Integral backdraught shutter already installed on the appliance: that prevents unwanted air from getting back in when the appliance is switched off.
- IPX4 splashproof protection on all models.



- Conforms to the following standards: CEI EN 60335-2-80 (part 2: Particular requirements for fan), CEI EN 60529 (code IP) and CEI I07-53/1986.
- Eco-Friendly: It guarantees a low environmental impact. Recyclable materials have been used and the “Design for Disassembly” technique has been followed (2002/96/EC-WEEE).

Design: F. Trabucco & Associati

### Accessories on request

- SCNR electronic speed controller (code 12912) for standard models.
- C 1,5 electronic speed controller (code 12912) for standard models.
- SCB Kit (code 22481) for SCNR.
- Fixed grille (code 22010 and 22020) for all products.
- Ceiling kit:  
(Ø 90-100 code 22162)  
(Ø 120 code 22163)  
(Ø 150 code 22164)

| Product      | Code  |       | V ~ 50 Hz | W  | A    | Rpm  | Delivery          |     | P max               |    | Lp dB(A)<br>3 m | Approvals | kg   | Insulation | IP     | °C max |    |
|--------------|-------|-------|-----------|----|------|------|-------------------|-----|---------------------|----|-----------------|-----------|------|------------|--------|--------|----|
|              |       | TIMER |           |    |      |      | m <sup>3</sup> /h | l/s | mm H <sub>2</sub> O | Pa |                 |           |      |            |        |        |    |
| MF 90/3.5"   | 11122 | 11126 | 230-240   | 14 | 0.08 | 2500 | 65                | 18  | 2.5                 | 25 | 28.8            |           | 0.50 |            | cl. II | X4     | 50 |
| MF 100/4"    | 11123 | 11127 | 230-240   | 15 | 0.09 | 2400 | 85                | 24  | 3                   | 29 | 31              |           | 0.51 |            | cl. II | X4     | 50 |
| MF 120/5"    | 11124 | 11128 | 230-240   | 20 | 0.12 | 2150 | 175               | 49  | 5                   | 49 | 34.4            |           | 0.61 |            | cl. II | X4     | 50 |
| MF 150/6"    | 11125 | 11129 | 230-240   | 28 | 0.15 | 2100 | 335               | 93  | 6                   | 59 | 40.1            |           | 0.97 |            | cl. II | X4     | 50 |
| MF 100/4" LL | 11131 | 11135 | 230-240   | 15 | 0.09 | 2400 | 85                | 24  | 3                   | 29 | 31              |           | 0.52 |            | cl. II | X4     | 50 |
| MF 120/5" LL | 11132 | 11136 | 230-240   | 20 | 0.12 | 2150 | 175               | 49  | 5                   | 49 | 34.4            |           | 0.62 |            | cl. II | X4     | 50 |
| MF 150/6" LL | 11133 | 11137 | 230-240   | 28 | 0.15 | 2100 | 335               | 93  | 6                   | 59 | 40.1            |           | 0.98 |            | cl. II | X4     | 50 |

## Pressure/performance curve

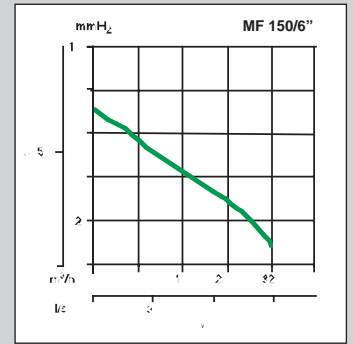
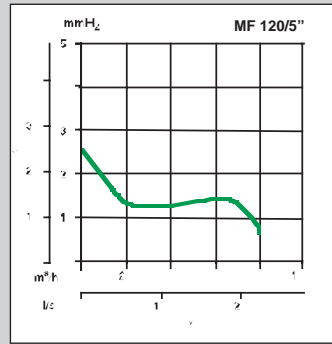
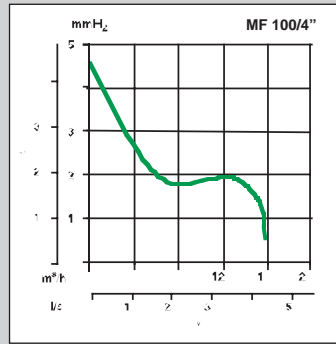
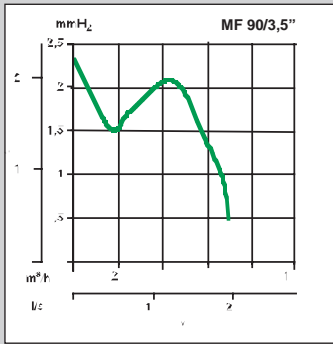





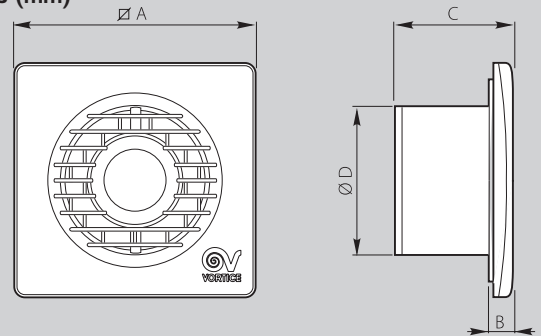

The front grille of just 17 mm and the roundness of the four sides makes the appliance "virtually" invisible. The design of a special miniaturized Timer has made it possible to keep the grille ultra-slim for these versions too.

## Dimensions (mm)



|                   | ∅ A | B  | C  | ∅ D  |
|-------------------|-----|----|----|------|
| <b>MF 90/3.5"</b> | 159 | 17 | 77 | 92.5 |
| <b>MF 100/4"</b>  | 159 | 17 | 77 | 98   |
| <b>MF 120/5"</b>  | 179 | 17 | 89 | 119  |
| <b>MF 150/6"</b>  | 214 | 17 | 96 | 156  |

## Accessories/Ancillaries

| Model   | Code            | Products   |
|---|-----------------|--|
|  SCNR electronic speed controller<br>C 1.5 electronic speed controller | 12912*<br>12966 | for standard models  |
|  SCB Kit   | 22481           | for SCNR (12912)   |
|  Fixed grille Ø 90-100   | 22010           | for all products   |
|  Fixed grille Ø 120-150  | 22020           | for all products   |
|  Ceiling kit (Ø 90 - 100)  | 22162           | 11122 - 11123 - 11126 - 11127<br>11130 - 11131 - 11134 - 11135 |
|  Ceiling kit (Ø 120)   | 22163           | 11124 - 11128 - 11132 - 11136                                  |
|  Ceiling kit (Ø 150)   | 22164           | 11125 - 11129 - 11133 - 11137                                  |

\* Upon stock depletion.