

Hamilton CHERITON VICTORIAN
1 GANG INTERMEDIATE
10AX ROCKER SWITCH

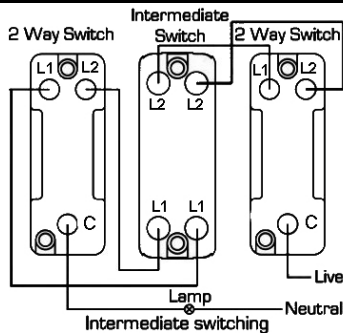

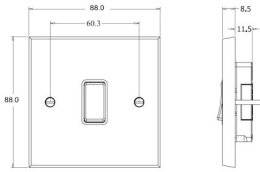

Order Code :
92 R31 PB-B

Cheriton Victorian Polished Brass 1 gang Intermediate 10AX Rocker. Standard Insert will be Polished Brass with a Black surround.

Attributes

Primary Range	Cheriton Victorian
Inst	R31
Plate material	Metal
Size (single) height	88mm
Size (single) width	88mm
Size (single) depth	8.5mm
Box fixing hole centres	60.3mm
Grid fixing hole centres	Grid fixing inserts are available on Cheriton Victorian plates. For full details refer to GRID-IT technical pages and GRID-IT catalogue
Minimum wall box depth	25mm
Current rating	10AX
Voltage	220/250V AC
Max load	10 Amp inductive
IP rating	IP2XD
Switched Poles	Single
Contact Gap Minimum	3mm
Terminal Capacity 1	5 x 1mm ²
Terminal Capacity 2	4 x 1.5mm ²
Terminal Capacity 3	1 x 2.5mm ²
Terminal Capacity 4	1 x 4mm ² Multi-Strand
Terminal Capacity 5	1 x 6mm ²
Earth Terminal Capacity 1	5 x 1mm ²
Earth Terminal Capacity 2	4 x 1.5mm ²
Earth Terminal Capacity 3	3 x 2.5mm ²
Earth Terminal Capacity 4	1 x 4mm ² Multi-Strand
Earth Terminal Capacity 5	1 x 6mm ²
Product Class 1	Must be earthed
Ambient Operating Temperature	-5Å° to +40Å°C
Recommended Location	Indoor use only
Max installation Altitude	2000m
BS EN ISO Standard	BS EN 60669-1
Patents And Trademarks	Trade Mark No. 2344779

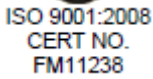
All products listed conform to current British or European standards and the product information is correct at the time of going to press.	All accessories are manufactured under an accredited BS EN ISO 9001 : 2008 Quality System.	It is the policy of the company to continually improve products as part of our development programme. Therefore, we reserve the right to alter designs and dimensions without prior notice.
Illustrations and diagrams are reproduced within the limitations of reproductions and printing processes are not binding.	Due to manufacturing processes we cannot guarantee an exact colour match and shadings of certain finishes.	   

R. Hamilton & Co Ltd. Unit G Quarry Industrial Estate MERE, Wiltshire UK BA12 6LA
 Tel: +44 (0)1747 860088 Fax: +44 (0)1747 861032 Email: info@hamilton-litestat.com Web: www.hamilton-litestat.com