

SHARK 525W

Classic Series

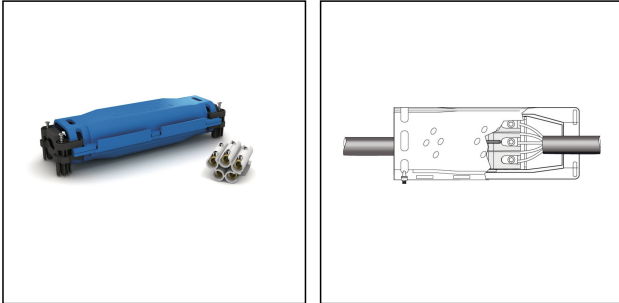

Products may differ in size, colour and appearance to those shown. If you require further information or customisation, please contact us directly.

Material	Polyamide
Filling	Silicone
Temp. range min	-20 °C
Temp. range max	90 °C
Glow wire test	self-extinguishing
Voltage	0,6 kV - 1 kV
Terminals/poles	3 - 5 x 6 - 16 mm ²
Quantity of cable	3 - 5
Order no. UK	SH525W
Type	SHARK 525W
Packing unit	1
ETIM-Classification	EC001169

Remarks:

Ampere: 135

Cable Size: (3 core) 2.5 - 16 mm (4 core) 2.5 - 16 mm (5 core) 2.5 - 10 mm

LxBxH: 69x180x40 mm

Description:

SHARK Pre-filled gel insulated straight joint. Includes retention clamp, earth braid and constant force roll springs. Perfect for steel wired armour cable.

Additional Info:

Ready to use, re-enterable, no mixing or pouring, immediate operation, excellent electrical insulation, good mechanical strength, no expiry date.

Your Contact:

WISKA UK Ltd.

Unit 7, Hurling Way · St. Columb Major Business Park · TR9 6SX, St. Columb Major, Cornwall · Great Britain

☎ +44-12-08816062 · 📠 +44-12-08816708



info@wiska.co.uk · www.wiska.co.uk

13.10.2020

Your Contact:

WISKA UK Ltd.

Unit 7, Hurling Way · St. Columb Major Business Park · TR9 6SX, St. Columb Major, Cornwall · Great Britain

 +44-12-08816062 ·  +44-12-08816708

info@wiska.co.uk · www.wiska.co.uk

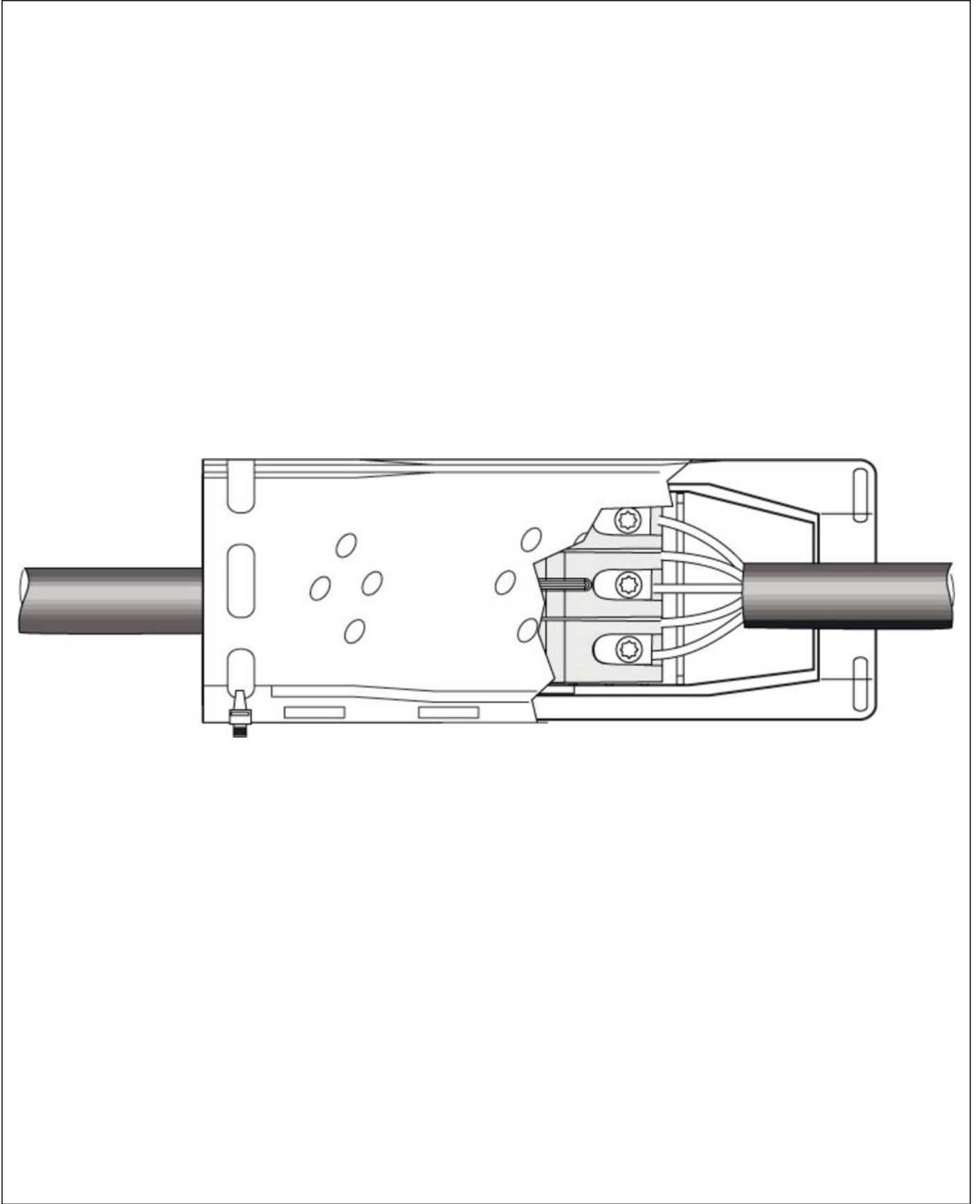

Your Contact:

WISKA UK Ltd.

Unit 7, Hurling Way · St. Columb Major Business Park · TR9 6SX, St. Columb Major, Cornwall · Great Britain

☎ +44-12-08816062 · 📠 +44-12-08816708

info@wiska.co.uk · www.wiska.co.uk