

INCEPTOR® SLATE

Technical Specification

Product Code: OV75302CW

Description: 30W 1200mm x 300mm LED Panel - 4000K - White

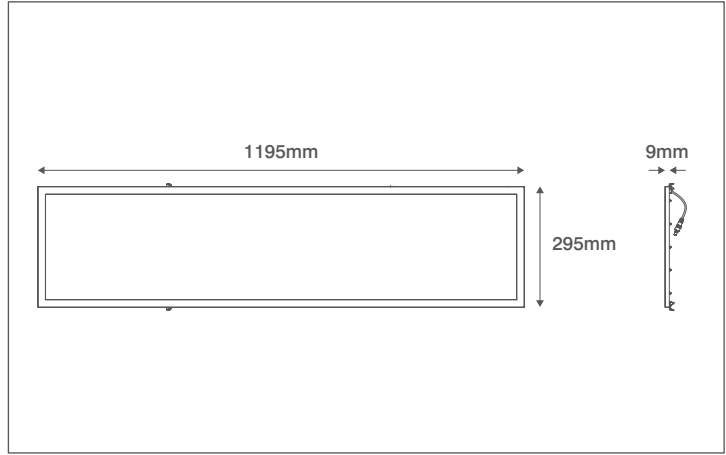
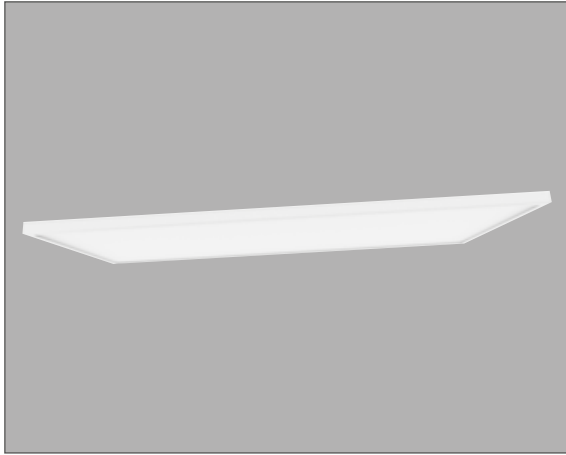

General Information

Dimensions	1195mm x 295mm x 9mm
Materials	Frame: Powdercoated Aluminium Diffuser: Polycarbonate Light Guide Plate (LGP): PMMA
Finish	White (RAL 9003)
Product Weight	2.4Kg
Dimmable	No
Ingress Protection	IP44
Flammability Rating	TP(a)
Warranty	5 Years

Supply & Power

Input Voltage & Frequency	220-240V ~ 50/60Hz
Electrical Safety	Class II (Double Insulated)
Input Power	30W
Input Current	139.5mA
In-rush Current	9.31A (460µs)
Power Factor	>0.9
Ambient Temperature (Ta)	-20°C - +40°C
Critical Temperature	+75°C
LED Driver	Remote Driver Supplied
Pre-wired Flow Connector	Yes (3 Pole CT105-F Push-fit Terminals)

Accessories

OVEMCG50	3 Hour Emergency Pack
OVSURF732	1200mm x 300mm Surface Frame Kit
OVSUSP733	Suspension Wire Kit

Luminaire Output

Colour Temperature	4000K
CRI	>80
Typical Luminous Flux	3250lm
Efficacy	105lm/W
Beam Angle	90°
Unified Glare Rating (UGR)	<19
Flicker Free	Yes
LED Lifetime (L70)	30,000 Hours
Flicker Free	Yes

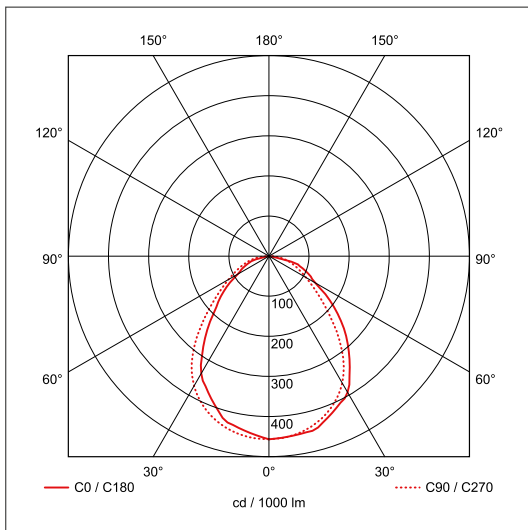

Additional Information

Suspension hooks pre-fitted to the back