

Product Code: OVMS001WH

Description: Surface Mounted 360° Low Profile Microwave Sensor - White

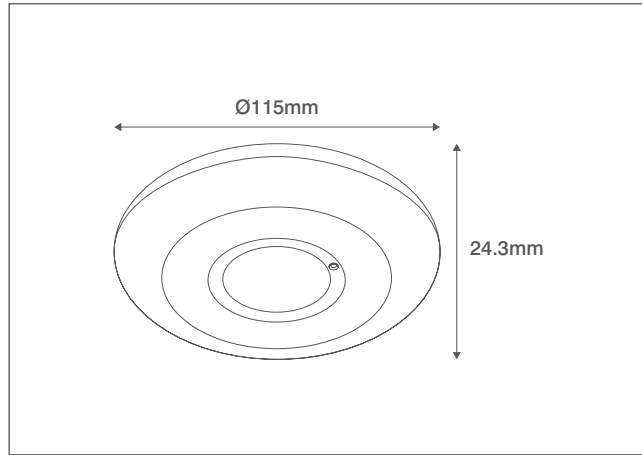
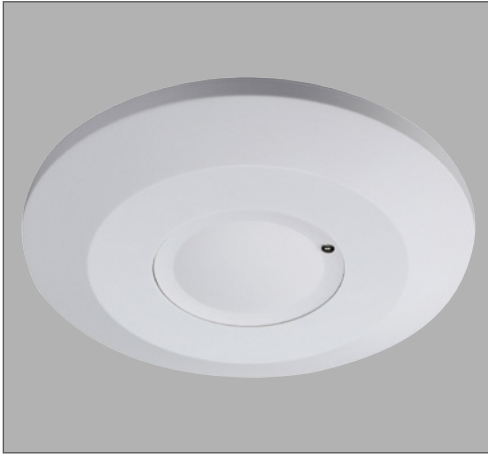

### General Information

Dimensions	115mm Diameter x 24.3mm (D)
Materials	Body: Polycarbonate (UV Stabilised)
Finish	White
Typical Mounting	Horizontal / Ceiling
Ingress Protection	IP20
Warranty	5 Years

### Supply & Power

Input Voltage & Frequency	220-240V~ 50/60Hz
Terminations	Input: Permanent Live & Neutral Output: Switched Live (All Screw Terminals)
Electrical Safety	Class II (Double Insulated)
Load Rating	1000W - LED & Compact Fluorescent 2000W - Incandescent & Halogen
Zero Cross Technology	Yes
Power Consumption	0.9W Approx.
Ambient Temperature (Ta)	-20°C - +40°C

### Sensor Parameters & Settings

Installation Height	2 Metres to 6 Metres	
Detection Distance	1 Metre to 8 Metres Radius	
Detection Angle	360°	
Detection Motion Speed	0.6-1.5m/s	
Manual Adjustments	Time Delay	10 Seconds (Min. +3 Seconds) to 12 Minutes (Max. + 1 Minute)
	Sensitivity	2 Metre Radius (Minimum) to 8 Metre Radius (Maximum)
	Lux Level	3 Lux (Minimum) to 2000 Lux (Maximum)

### Detection Area Schematics

