

# INCEPTOR® SLATE

## Technical Specification

Product Code: OV75301CW

Description: 30W 600mm x 600mm LED Panel - 4000K - White

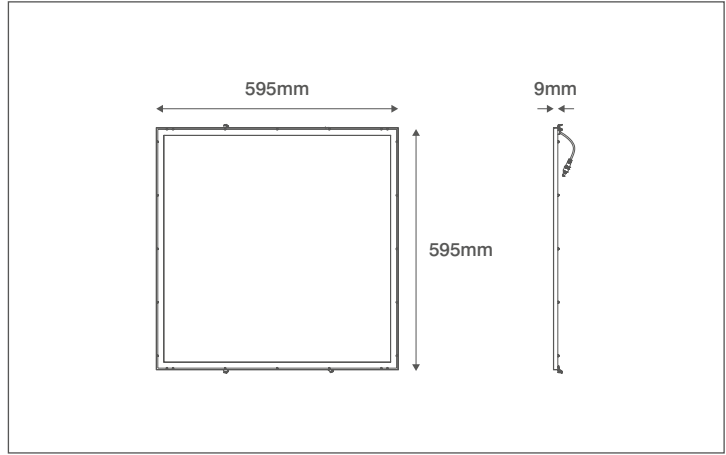
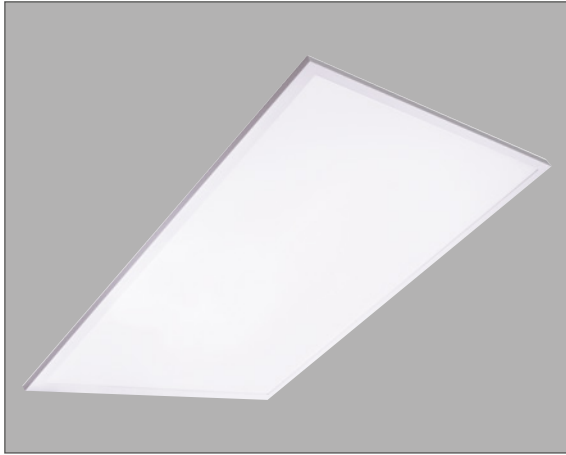

### General Information

Dimensions	595mm x 595mm x 9mm
Materials	Frame: Powdercoated Aluminium Diffuser: Polycarbonate Light Guide Plate (LGP): PMMA
Finish	White (RAL 9003)
Product Weight	2.4Kg
Dimmable	No
Ingress Protection	IP44
Flammability Rating	TP(a)
Warranty	5 Years

### Supply & Power

Input Voltage & Frequency	220-240V ~ 50/60Hz
Electrical Safety	Class II (Double Insulated)
Input Power	30W
Input Current	139mA
In-rush Current	9.31A (460µs)
Power Factor	>0.9
Ambient Temperature (Ta)	-20°C - +40°C
Critical Temperature	+75°C
LED Driver	Remote Driver Supplied
Pre-wired Flow Connector	Yes (3 Pole CT105-F Push-fit Terminals)

### Accessories

OVEMCG50	3 Hour Emergency Pack
OVSURF731	600mm x 600mm Surface Frame Kit
OVREC731	600mm x 600mm Recess Frame Kit
OVSUSP731	Suspension Wire Kit

### Luminaire Output

Colour Temperature	4000K
CRI	>80
Typical Luminous Flux	3250lm
Efficacy	105lm/W
Beam Angle	90°
Unified Glare Rating (UGR)	<19
Flicker Free	Yes
LED Lifetime (L70)	30,000 Hours
Flicker Free	Yes

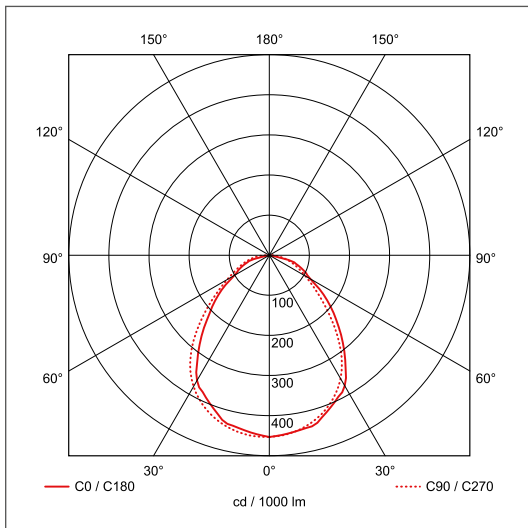

### Additional Information

Suspension hooks pre-fitted to the back