

Technical Data Sheet
Code 46312
125mm to 100mm Reducer Plastic

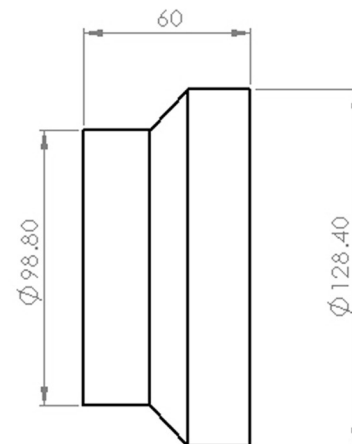
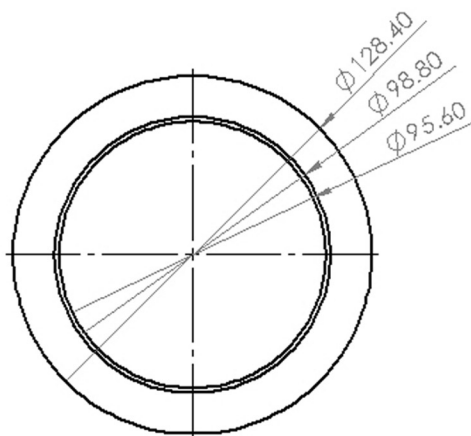

SPECIFICATION DETAILS

The 46312 125mm -100mm diameter Reducer is manufactured from (white) High Impact Polystyrene and has a minimum free area on the 125mm diameter of 12,266mm² that reduces to 100mm diameter free area of 7,283mm². It has a male spigot for connection inside of the System 100 duct.

46312 is manufactured in compliance with Domestic Plastic Ductwork Specification DW/154 and does meet UL94HB flammability standard.

Box quantity: 40

Individual Weight: 40g

MAX/MIN OPERATING TEMPERATURES + 60°C to - 15°C

Colour: White

PERFORMANCE CURVE

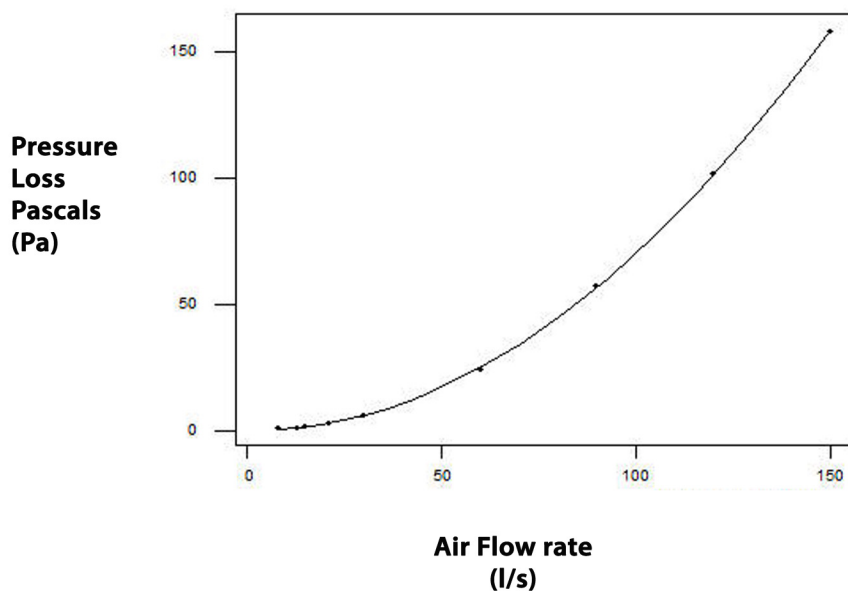

AIRFLOW

RESISTANCE

8 l/s	0.80 pa
13 l/s	1.30 pa
21 l/s	3.20 pa
30 l/s	5.90 pa
60 l/s	24.00 pa
120 l/s	102.00 pa