

**Technical Data Sheet**  
**Code 46024, 46028, 46032, 46036**  
**100mm Gravity Grille**

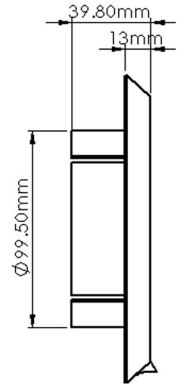
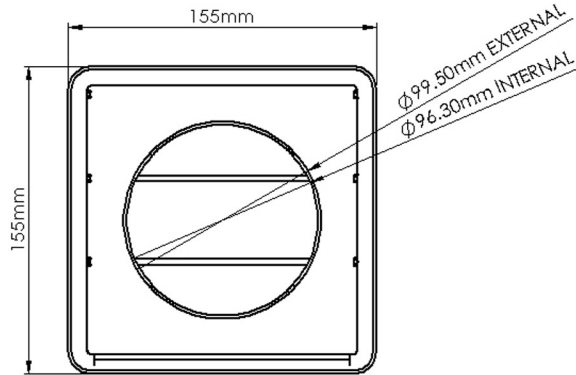

**SPECIFICATION DETAILS**

The 100mm diameter Gravity Grille Round Spigot is manufactured from Polypropylene and has a minimum free area of 7,283mm<sup>2</sup>. It has a male spigot for connection inside of the System 100 duct.

The Gravity Outlet is supplied complete with 3 anti-backdraught shutters which will open during fan operation and close when the fan is switched off. The outlet will prevent external airflow or wind pressure from traveling up the duct and into the property.

The Gravity Outlet is manufactured in compliance with Domestic Plastic Ductwork Specification DW/154 and does meet UL94HB flammability standard.

**Box quantity:** 20

**Individual Weight:** 80g

**MAX/MIN OPERATING TEMPERATURES** + 60°C to - 15°C

**Colour:** White, Brown, Beige, Terrocatta

**PERFORMANCE CURVE**

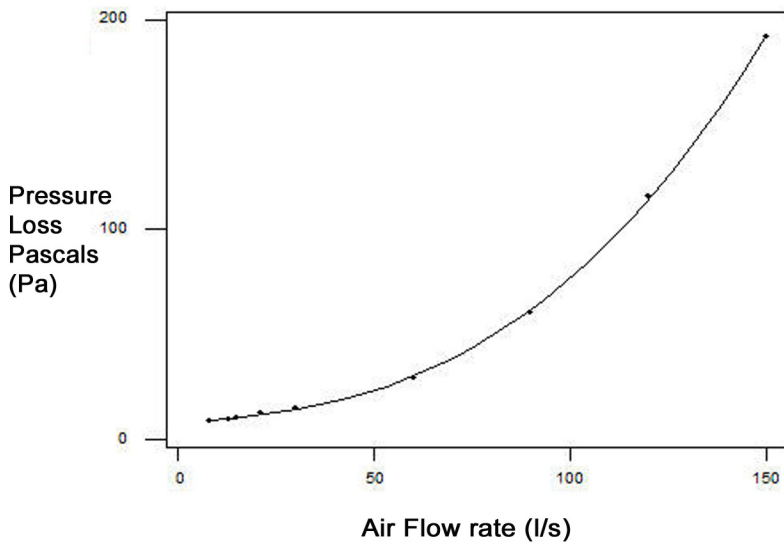

AIRFLOW	RESISTANCE
8 l/s	9.00 pa
13 l/s	10.00 pa
21 l/s	13.00 pa
30 l/s	15.00 pa
60 l/s	30.00 pa
120 l/s	116.10 pa