

1619A00XP10001

Robert Bosch Limited
Power Tools Division
PO Box 98, Uxbridge,
Middlesex, UB9 5HN.
United Kingdom
www.boschpowertools.co.uk



1 619 A00 XP1 - en - PT-AC/MKB1 - Printed in Germany - Imprimé en Allemagne -
Subject to technical alterations. Liability for printing errors is not accepted. Valid from: 01.09.2014
Segment Catalogue 4 - 2nd edition
Printed at Werbedruck GmbH Horst Schreckhase, Dörnbach 22, 34286 Spangenberg, Germany.

Bosch: Focusing on perfect cuts.

The circular saw blade range.

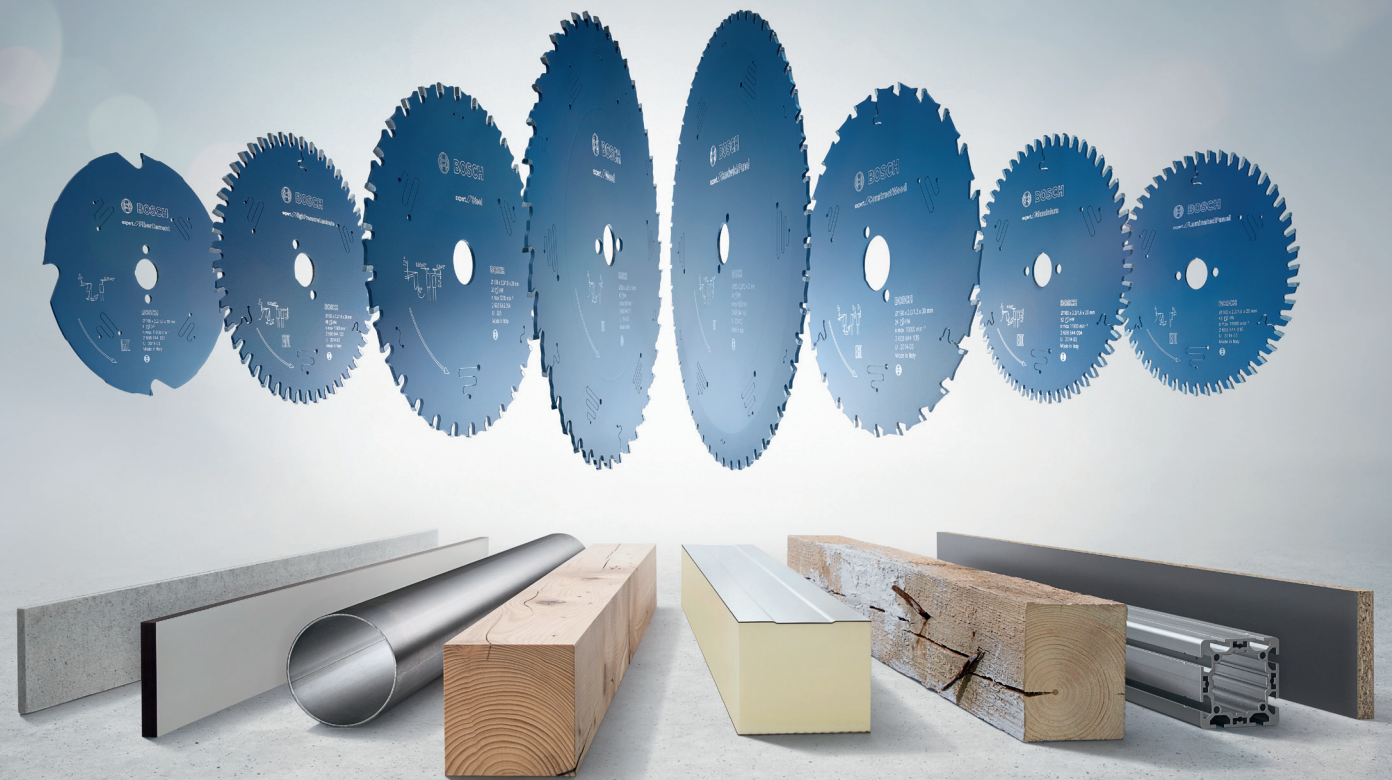

BOSCH
Invented for life

Circular sawing, routing



BOSCH
Invented for life

Accessory range

Overview

Innovative and efficient products ensure sales success. The research and development departments at Bosch work to continuously develop and optimise accessories in line with the needs of professionals.



Universal accessories

- Metal and wood drilling
- Accessories for screwdriving
- Machine accessories
- Cordless working
- Work safety



The circular saw blade range

- Circular sawing
- Routing



The concrete and masonry range

- Hammer drilling
- Masonry drilling
- Chiselling



The jigsaw blade range

- Jigsawing
- Sabre sawing
- Multi-cutters
- Holesawing



The diamond accessory range

- Diamond cutting
- Diamond grinding
- Diamond drilling



The cutting and grinding disc range

- Sanding and polishing
- Cutting and grinding
- Brushing

Bosch Customer Service

Have any questions about our products and applications?
 Tel.: 0344 736 0109
 Fax: 0344 736 0146
 Mon - Fri: 8:30 - 17:00
 boschservicecentre@uk.bosch.com

Calls are charged at 4 pence per minute from a BT landline, call charges from other networks will vary and mobiles may be significantly more.
 This number connects you to the Bosch application adviser team.
 It is there to answer your queries regarding technical matters and for quick and user friendly customer service.
 Outside office hours an answer phone will take your message.

Packaging

information system

Technical information / Applications

Material / Machines

Hand-held circular saw	Plunge saw	Multi-router
Table saw	Pull-push saw	Horizontal panel sizing saw
Vertical panel sizing saw	Mitre saw	Mitre dry cutters
Hand dry cutters	Router	Table router
CNC router		

Features

microteQ Circular sawing	cleanteQ Circular sawing	proteQtion Circular sawing
stabiliteQ Circular sawing	Vibration Control Circular sawing	Dura Technology Circular sawing
microteQ Routing	cleanteQ Routing	proteQtion Routing
Silent	Precise	

Advantages

For effortless cuts	Clean cut	Very clean cut
Long lifetime	Very long lifetime	Clean cuts over the entire lifetime

Safety

Wear protective glasses	Wear dust mask	Wear ear protectors
-------------------------	----------------	---------------------

Table of contents

Overview	
Expertise from Bosch	4
Range expertise	6
Circular sawing	
Introduction	8
The Best range	
Overview	12
Top Precision Best for Wood	14
Top Precision Best for Laminated Panel Abrasive and Fine	16
Top Precision Best for Multi Material	19
Best for Laminate	20
The Expert range	
Overview	21
Expert for Wood	24
Expert for Construct Wood	30
Expert for Laminated Panel	31
Expert for High Pressure Laminate	34
Expert for Multi Material	35
Expert for Aluminium	36
Expert for Steel	40
Expert for Sandwich Panel	42
Expert for Fiber Cement	43
The Standard range	
Overview	44
Optiline Wood	46
Speedline Wood	49
Construct Wood	51
Multi Material	53

Routing	
Overview	68
The Standard range	
Overview	71
Precise bits for joining	73
Shaping bits for profiling	83
Accessories for Bosch universal routers and biscuit jointers	96
General information	
Index	98
Date of production or packing	100
Ordering and packaging control system	101
Packaging overview	102
Pictograms	107



Circular saw blades and router bits

Expertise from Bosch



Manufacturing expertise

We use state-of-the-art, technologically pioneering machines and processes, such as steel sheets laser cutting, carbide tip brazing and teeth grinding, in the world's largest factory for premium quality circular saw blades, which guarantees the superior quality of our products.

Innovative research and development

Our modern development and research centre for cutting tools enables us to continuously improve and innovate. The new technology of polyurethane (PUR) filled slots for low-noise blades is an example of our many innovative solutions.

Unique features

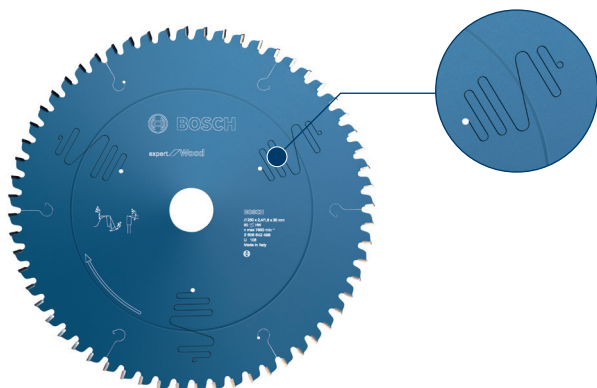

Vibration Control

Specially designed anti-vibration slots ensure particularly smooth running. The arrangement of the slots, which is based on discoveries made in laboratory simulations, reduces noise and vibration.

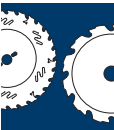

Leader in carbide technology

Our in-house production of carbide powder is unique in the world. Using precise mixtures of cobalt, titanium and tungsten, we create different blends that are specifically designed to maximise lifetime and material finish.

Leader in coating technology

We manufacture our unique Cleanteq and Protection coatings ourselves. Their cooling and non-stick properties increase the lifetime of the accessory and enable precise cuts.



Microteq

Some of the carbides we produce are made of an extremely fine grit (Microteq). Carbide grain size is important when it comes to sharpness as well as the wear life of a cutting edge. The finer the carbide grain, the less quickly an edge will wear. Our carbide powder has fine to very fine grain sizes, enabling us to offer a high level of reliability with regard to cut quality and lifetime of the accessory.



Protection and Cleanteq coatings

Our special coatings minimise the adhesion of residues such as resin or sap on the accessory. Friction is prevented and the build up of heat is reduced. The coating is also highly anti-corrosive, which improves lifetime and cutting precision.

Circular saw blades

Range expertise

Best ◆◆◆◆



For very demanding applications – Industrial quality

Expert ◆◆◆◆



For perfect cuts you can rely on

Standard ◆◆◆◆



Ideal for optimum cuts

Tooth	Microteq	Microteq	Standard carbide
Coating	Cleanteq	Proteqtion	Dry-lacquered
Anti-vibration slots	Stabilteq	Vibration Control	Partly
Steel body	Laser-cut	Laser-cut	Laser-cut or punched
Tensioning ring	Present	Present	Present
Expansion slot	Laser-cut	Laser-cut	Laser-cut or punched

Router bits

Range expertise

Expert ◆◆◆◆

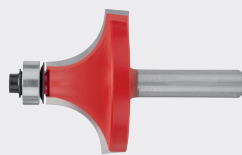

For perfect results you can rely on

Standard ◆◆◆◆



Ideal for optimum results

Carbide	Microteq	Standard carbide
Coating	Proteqtion, Cleanteq	Electrostatic powder coating
Cutting angle	0° shear angle and inclined shear angle	0° shear angle
Working length	Straight bits and laminate trim bits over 50 mm	Straight bits up to 40 mm



expert  Wood

Circular sawing



BOSCH
Ø254 x
60 [1] H
n max
2 608
U 31
Mod



The perfect blade for every application





Best ★★★★★

Best for Wood	Best for Laminated Panel Abrasive	Best for Laminated Panel Fine	Best for Multi Material	Best for Laminate
Wood	Composites		Multi Material	Laminate flooring
Page 14	Page 16	Page 17	Page 19	Page 20

Expert ★★★★★









Expert for Wood	Expert for Construct Wood	Expert for Laminated Panel
Wood	Construction timber	Composites
Page 24	Page 30	Page 31

Wood materials

 Hardwood	●			○	
 Softwood	●			○	
 Construction timber with nails and concrete residues					
 Construction timber					

●		
●		
	●	
	●	

Composites

 Formwork boards					
 Chipboard (raw), acoustic panels, lightweight building panels	●	●	●	●	●
 Abrasive panel materials coated on one or two sides - Hard coating	○	●	○	○	
 Panel materials, veneered laminate, thin chipboards	○	○	●	○	
 Composite material	●			○	
 Pressed laminated wood, plywood	●				
 Fibre materials, MDF, OSB, MDF composite panels	●			●	
 Wood core plywood	●			○	
 Laminate flooring, parquet	○			○	●
 High pressure laminate panels, suitable for Trespa®				○	

	●	
●	●	●
○		●
○		●
●		
●		
●		
○		

Other materials

 Porous concrete					
 Plastics, epoxy				●	
 Non-ferrous metals, aluminium, brass, copper				●	
 Steel					
 Sandwich panels, laminated on one or two sides					
 Fibre cement, suitable for Eternit®					
 Plasterboard					
 Suitable for Corian®					

	●	

● especially suitable ○ suitable

Expert for High Pressure Laminate	Expert for Aluminium	Expert for Steel	Expert for Sandwich Panel	Expert for Fiber Cement
Trespa®, high pressure laminate panels	Aluminium	Steel*	Sandwich panels	Fibre cement
Page 34	Page 36	Page 40	Page 42	Page 43

	○			
	○			

	●			
	●			
	○			
	○			
	●			
	○			
	○			
●				

				●
	●			
	●			
		●*		
			●	
				●
				●
○				○

Standard ◆◆◆

Optiline Wood	Speedline Wood	Construct Wood	Multi Material
Wood	Quick cuts in wood	Construction timber	Multi Material
Page 46	Page 49	Page 51	Page 53

●	●		○
●	●		○
		●	
		●	

	●	●	
●	●	●	●
○			○
○			○
●			○
●			
●			●
●	○		○
○			○
			○

		●	
			●
			●

* Not for inox

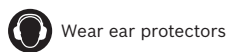
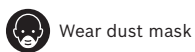
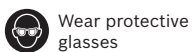

You will find a comprehensive range of protective glasses, dust masks, etc. in Segment Catalogue No. 1 starting on page 265.

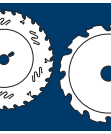

Permanent product information on the circular saw blade

Resharpener made easy!

All our circular saw blades are laser-marked with:

- ▶ A tooth geometry diagram
- ▶ Information about: hook angle, relief angle, ATB angle or chamfer angles, height difference between teeth (for HLTCG or DH tooth geometry)

This permanently marked information allows professional resharpeners to resharpen safely in accordance with original blade specifications, to ensure an outstanding cutting result and increase the blade's working life.

Permanent marking

Clearly visible, permanent product information on the circular saw blade makes it quick and easy to identify for a follow-up purchase. The manufacturing site and date are laser etched on the blade to ensure it can always be traced back to source.



Product information on the packaging

The packaging information is identical to the information in the catalogue, making it easier to find products from the catalogue to the packaging and vice versa.

Performance category/symbols

The performance category guides you to the right product for your individual needs.

Selection guide/Colour coding

Selection guide and colour coding provide information about suitable use. See page 8/9.

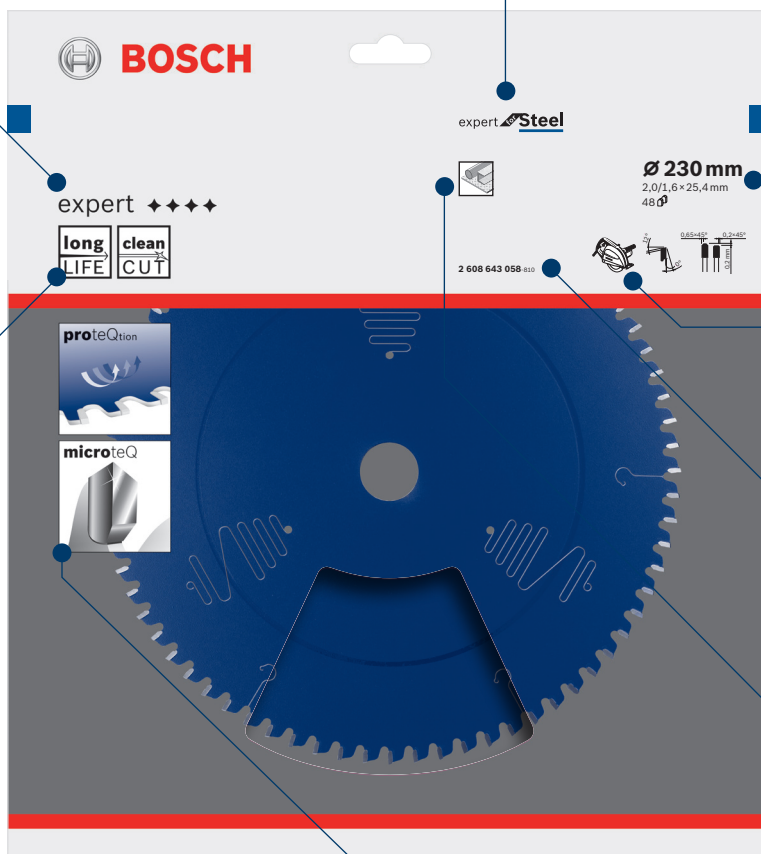

Technical specifications

Blade diameter, blade/tooth thickness, number of teeth.

Machine illustration

Machine illustrations show you which type of machine the accessory can be used with.

Part number

The part number clearly identifies each product and also serves as an order number.

Material pictograms

Material/application pictograms show which materials can be worked on and indicate special application possibilities.

Product benefit pictograms

Product benefit pictograms describe the user benefit of a product, e.g. a long lifetime, a fast cut or a perfect cut.

See page 107.



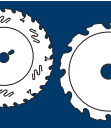

Feature illustrations

Feature illustrations show special product features which affect the benefit and quality of the product.

See page 107.



Best ◆◆◆◆◆









- best  Wood
- best  LaminatedPanel abrasive
- best  LaminatedPanel fine
- best  Laminate
- best  MultiMaterial



Best
◆◆◆◆◆



Expert ◆◆◆◆◆

► Page 21

- | | |
|---|--|
| expert  Wood | expert  Aluminium |
| expert  LaminatedPanel | expert  Steel |
| expert  ConstructWood | expert  SandwichPanel |
| expert  HighPressureLaminate | expert  FiberCement |
| expert  MultiMaterial | |

Standard ◆◆◆

► Page 44

- 
- 
- 
- 

Best

For very demanding applications – Industrial quality

Best for Wood, Laminated Panel Abrasive, Laminated Panel Fine, Multi Material

 **TOP Precision**

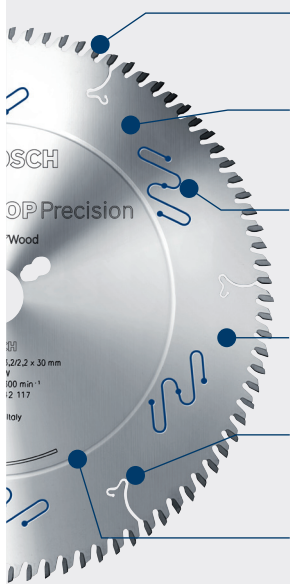

Microteq teeth

Manufactured from extra-hard, durable carbide grains. Unique – from in-house production.



Cleanteq coating

Reduces the adhesion of residues (resin, glue) – ensuring extra-clean results. Protects the blade against corrosion. Keeps the blade cool.



Vibration reduction with Stabilteq

Polyurethane-filled anti-vibration slots: significant reduction in vibration and noise. This improves cutting precision and ease of working.

Steel body

Premium steel (up to HRC 46) for high endurance. Laser-cut for high precision and no blade warping.

Expansion slots

Laser-cut for high blade stability and accuracy. The special design of the slot reduces noise levels.

Tensioning ring

The blades remain dimensionally stable and perfectly flat, also during use, thanks to the specially rolled-in tensioning ring.



Best for Laminate



Microteq teeth

Manufactured from extra-hard, durable carbide grains. Unique – from in-house production.



Protection coating

High-end technology coating for reliable cutting performance – prevents corrosion and reduces friction.



Vibration Control

Specially designed anti-vibration slots for particularly smooth running, considerably less noise and significantly reduced vibration.

Steel body

Premium steel (up to HRC 46) for high endurance. Laser-cut for high precision and no blade warping.

Expansion slots

Laser-cut for high blade stability and accuracy. The special design of the slot reduces noise levels.

Tensioning ring

The blades remain dimensionally stable and perfectly flat, also during use, thanks to the specially rolled-in tensioning ring.



Very coarse cut

Fast rip cuts and cross cuts in softwood, hardwood, raw chipboards and formwork boards



Fine cut

Cross cuts in softwood, hardwood, plywood, wood core plywood, chipboards laminated on one side, and parquet



Coarse cut

Rip and cross cuts in softwood, hardwood, raw chipboards, formwork boards and plywood



Very fine cut

Cross cuts in softwood, hardwood, plywood, wood core plywood, parquet, fibre materials and MDF

Circular saw blades for plunge and hand-held circular saws

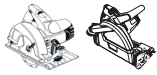

- For precise, clean and quiet cuts in all types of wood with plunge and hand-held circular saws.

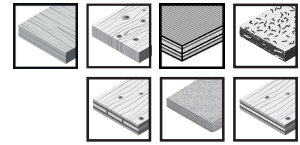

TOP Precision best for Wood

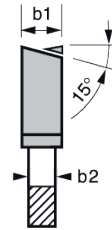
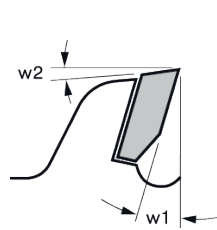

ATB
 w1: hook angle
 w2: relief angle
 b1: width of cut
 b2: base blade thickness

Product properties							Ordering information					
Outer diameter mm	Bore size mm	Width of cut (b1) mm / Base blade thickness (b2) mm	Number of teeth	Tooth shape	Cutting result	Hook angle ° w1	Relief angle ° w2	Part number	Packaging type	Pack quantity	Minimum order quantity	Barcode 3165140...
165	20 1.8/1.3	20	ATB	●●	15	15	2 608 642 385	C1a	1	1	636865	
165	20 1.8/1.3	32	ATB	●●●	10	15	2 608 642 386	C1a	1	1	636872	
165	20 1.8/1.3	48	ATB	●●●●	5	15	2 608 642 384	C1a	1	1	636858	

Circular saw blades for mitre saws and sliding mitre saws



- For precise, clean and quiet cuts in all types of wood.

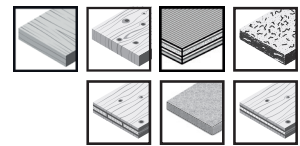

TOP Precision best for Wood

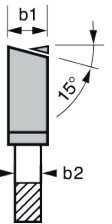
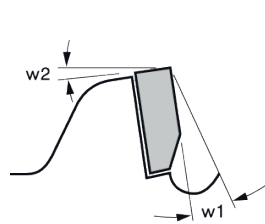
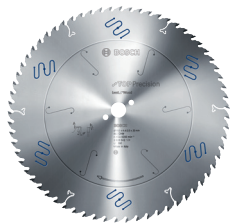

ATB
 w1: hook angle
 w2: relief angle
 b1: width of cut
 b2: base blade thickness

Product properties							Ordering information						
Outer diameter mm	Bore size mm	Width of cut (b1) mm / Base blade thickness (b2) mm	Number of teeth	Tooth shape	Cutting result	Pin hole/pitch circle diameter	Hook angle ° w1	Relief angle ° w2	Part number	Packaging type	Pack quantity	Minimum order quantity	Barcode 3165140...
210	30 2.3/1.8	48	ATB	●●	-	-5	15	2 608 642 100	C1c	1	1	574402	
216	30 2.3/1.8	48	ATB	●●	-	-5	15	2 608 642 101	C1c	1	1	574419	
254	30 2.3/1.8	60	ATB	●●●	-	-5	15	2 608 642 102	C1c	1	1	574426	
305	30 2.3/1.8	72	ATB	●●●	-	-5	15	2 608 642 103	C1c	1	1	574433	



Circular saw blades for horizontal/vertical panel sizing and table saws

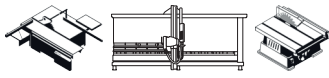
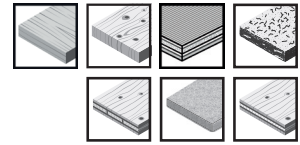

TOP Precision best **for Wood**

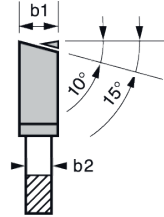
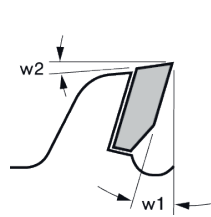

ATB
 w1: hook angle
 w2: relief angle
 b1: width of cut
 b2: base blade thickness



Outer diameter mm	Bore size mm	Width of cut (b1) mm / Base blade thickness (b2) mm	Number of teeth	Tooth shape	Cutting result	Pin hole/Pitch circle diameter	Hook angle ° w1	Relief angle ° w2	Part number	Packaging type	Pack quantity	Minimum order quantity	Barcode 3165140...
Product properties								Ordering information					
250	30	3.2/ 2.2	40	ATB ●●	7/42 9/46.4 10/60	15	15	2 608 642 111	C1c	1	1	574518	
250	30	3.2/ 2.2	60	ATB ●●●	7/42 9/46.4 10/60	10	15	2 608 642 112	C1c	1	1	574525	
250	30	3.2/ 2.2	80	ATB ●●●●	7/42 9/46.4 10/60	5	18	2 608 642 113	C1c	1	1	574532	
300	30	3.2/ 2.2	48	ATB ●●	7/42 9/46.4 10/60	15	15	2 608 642 114	C1c	1	1	574549	
300	30	3.2/ 2.2	60	ATB ●●●	7/42 9/46.4 10/60	10	15	2 608 642 115	C1c	1	1	574556	
300	30	3.2/ 2.2	72	ATB ●●●●	7/42 9/46.4 10/60	10	15	2 608 642 116	C1c	1	1	574563	
300	30	3.2/ 2.2	96	ATB ●●●●	7/42 9/46.4 10/60	5	18	2 608 642 117	C1c	1	1	574570	
315	30	3.2/ 2.2	48	ATB ●●	7/42 9/46.4 10/60	15	15	2 608 642 119	C1c	1	1	574594	
315	30	3.2/ 2.2	72	ATB ●●●	7/42 9/46.4 10/60	10	15	2 608 642 118	C1c	1	1	574587	
350	30	3.5/ 2.5	54	ATB ●●●	9/46 10/60	15	15	2 608 642 120	C1c	1	1	574600	
350	30	3.5/ 2.5	84	ATB ●●●●	9/46 10/60	10	15	2 608 642 121	C1c	1	1	574617	
400	30	4.0/ 2.8	60	ATB ●●●	10/60	15	15	2 608 642 122	C0a	1	1	574624	
400	30	4.0/ 2.8	96	ATB ●●●●	10/60	10	15	2 608 642 123	C0a	1	1	574631	
450	30	4.4/ 3.0	66	ATB ●●●	2/ 10/60	15	15	2 608 642 124	C0a	1	1	574648	
500	30	4.4/ 3.2	60	ATB ●●	2/ 10/80	15	15	2 608 642 125	C0a	1	1	574655	

Circular saw blades for horizontal/vertical panel sizing and table saws

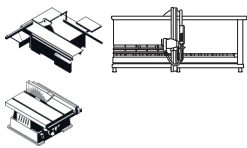
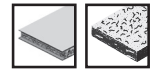

- ▶ For perfect cuts in abrasive panel materials coated on one or two sides.
- DH: Scoring blade not required when used on panel sizing saws.

TOP Precision best Laminated Panel abrasive

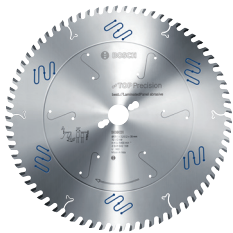

DH

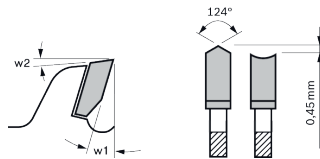

w1: hook angle
w2: relief angle

HLTCG

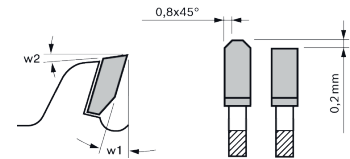

Outer diameter mm	Bore size mm	Width of cut (b1) mm / Base blade thickness (b2) mm	Number of teeth	Tooth shape	Cutting result	Pin hole/Pitch circle diameter	Hook angle ° w1	Relief angle ° w2	Part number	Packaging type	Pack quantity	Minimum order quantity	Barcode 3163140...
Product properties								Ordering information					
250	30	3.2/2.2	48	DH	●●●	7/42 9/46.4 10/60	10	15	2 608 642 104	C1c	1	1	574440
250	30	3.2/2.2	80	HLTCG	●●●●	7/42 9/46.4 10/60	5	18	2 608 642 109	C1c	1	1	574495
300	30	3.2/2.2	96	HLTCG	●●●●	7/42 9/46.4 10/60	5	18	2 608 642 110	C1c	1	1	574501
303	30	3.2/2.2	60	DH	●●●	7/42 9/46.4 10/60	10	15	2 608 642 106	C1c	1	1	574464
350	30	3.2/2.2	72	DH	●●●	7/42 9/46.4 10/60	10	15	2 608 642 108	C1c	1	1	574488



Circular saw blades for horizontal/vertical panel sizing and table saws

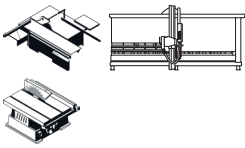

- ▶ For perfect cuts in panels fine-coated on one or two sides and veneered panels.
- ATB: Suitable for all panel sizing and table saws.

TOP Precision best **for Laminated Panel** fine

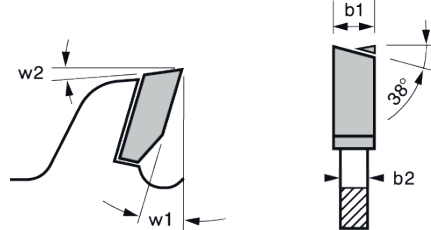

ATB
 w1: hook angle
 w2: relief angle
 b1: width of cut
 b2: base blade thickness



Outer diameter mm	Bore size mm	Width of cut (b1) mm / Base blade thickness (b2) mm	Number of teeth	Tooth shape	Pin hole/Pitch circle diameter	Cutting result	Hook angle ° w1	Relief angle ° w2	Part number	Packaging type	Pack quantity	Minimum order quantity	Barcode 3163140...
300	30	3.2/ 2.2	96	ATB	7/42 9/46.4 10/60	●●●●	2	25	2 608 642 105	C1c	1	1	574457
350	30	3.5/ 2.5	108	ATB	9/46.4 10/60	●●●●	5	25	2 608 642 107	C1c	1	1	574471

Scoring blades for horizontal/vertical panel sizing saws

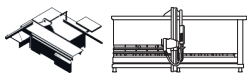
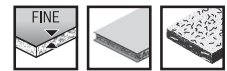

- ▶ Adjustable scoring blades for cutting to size panels coated on one or two sides.

TOP Precision best for LaminatedPanel

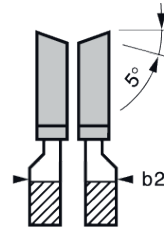
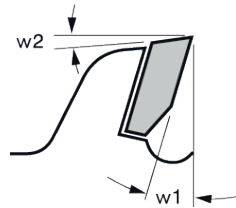

ES
 w1: hook angle
 w2: relief angle
 b1: width of cut
 b2: base blade thickness

Product properties	Ordering information
Outer diameter mm: 80	Part number: 2 608 642 126
Bore size mm: 20	Packaging type: C1c
Width of cut (b1) mm: 2.8-3.6	Pack quantity: 1
Number of teeth: 10+10	Minimum order quantity: 1
Tooth shape: ES	Barcode: 574662
Cutting result: ●●●●	
Hook angle ° w1: 11	
Relief angle ° w2: 17	
	2 608 642 127
	2 608 642 128
	2 608 642 129
	2 608 642 130
	2 608 642 131

Conical scoring blades for horizontal/vertical panel sizing saws

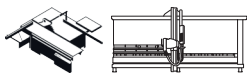
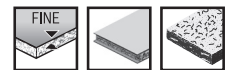

- ▶ Conical scoring blades for cutting to size panels coated on one or two sides.

best for LaminatedPanel

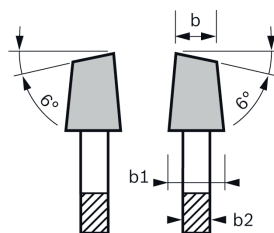
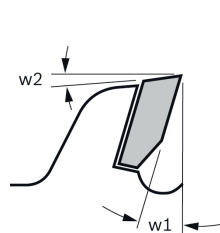

K-WZ
 w1: hook angle
 w2: relief angle
 b1: width of cut
 b2: base blade thickness

100	20	3.1-4.3	24	K-WZ	●●●●	0	15	2 608 642 607	C1c	1	1	666602
100	22	3.1-4.3	24	K-WZ	●●●●	0	15	2 608 642 606	C1c	1	1	666596
120	20	3.1-4.3	24	K-WZ	●●●●	0	15	2 608 642 610	C1c	1	1	666633
125	20	3.1-4.3	24	K-WZ	●●●●	0	15	2 608 642 609	C1c	1	1	666626
125	22	3.1-4.3	24	K-WZ	●●●●	0	15	2 608 642 608	C1c	1	1	666619

Best
★★★★★

Circular saw blades for plunge and hand-held circular saws

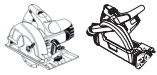
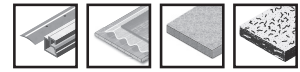

- ▶ For excellent results in non-ferrous metals, aluminium, plastics, epoxy and wood with plunge and hand-held circular saws.

TOP Precision best **MultiMaterial**

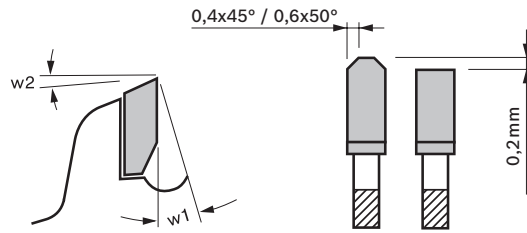

HLTCG
w1: hook angle
w2: relief angle

Outer diameter mm	Bore size mm	Width of cut (b1) mm / Base blade thickness (b2) mm	Number of teeth	Tooth shape	Cutting result	Hook angle ° w1	Relief angle ° w2	Part number	Packaging type	Pack quantity	Minimum order quantity	Barcode 3165140...
Product properties							Ordering information					
165	20	1.8/1.3	48	HLTCG	●●●●	0	17	2 608 642 388	C1a	1	1	636896
165	20	1.8/1.3	56	HLTCG	●●●●	-5	15	2 608 642 387	C1a	1	1	636889

Circular saw blades for mitre saws and sliding mitre saws

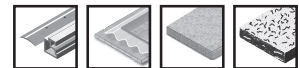

- ▶ For excellent results in non-ferrous metals, aluminium, plastics, epoxy and wood.
- ▶ Using the universal cutting oil 2 607 001 409 increases the lifetime several times over when cutting in metal, e.g. aluminium.

TOP Precision best **MultiMaterial**

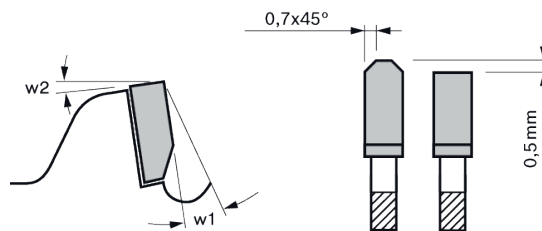
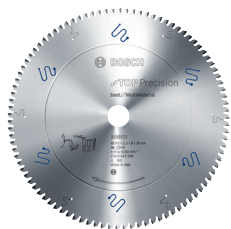

TCG
w1: hook angle
w2: relief angle

210	30	2.3/1.8	54	HLTCG	●●●	-5	15	2 608 642 096	C1c	1	1	574365
216	30	2.3/1.8	64	HLTCG	●●●	-5	15	2 608 642 097	C1c	1	1	574372
254	30	2.3/1.8	80	HLTCG	●●●●	-5	15	2 608 642 098	C1c	1	1	574389
305	30	2.3/1.8	96	HLTCG	●●●●	-5	15	2 608 642 099	C1c	1	1	574396



Circular saw blades for mitre saws and sliding mitre saws

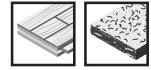

► A durable blade for all types of laminate flooring.

best **for Laminate**

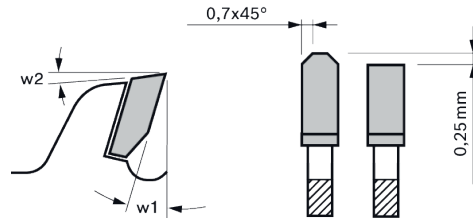

HLTCG
w1: hook angle
w2: relief angle

Outer diameter mm	Bore size mm	Width of cut (b1) mm / Base blade thickness (b2) mm	Number of teeth	Tooth shape	Cutting result	Hook angle ° w1	Relief angle ° w2	Part number	Packaging type	Pack quantity	Minimum order quantity	Barcode 3163140...
216	30	2.5/ 1.8	60	HLTCG	●●●●	5	15	2 608 642 133	C1c	1	1	579568
254	30	2.5/ 1.8	84	HLTCG	●●●●	5	15	2 608 642 135	C1c	1	1	579575
305	30	2.5/ 1.8	96	HLTCG	●●●●	5	18	2 608 642 137	C1c	1	1	579582



Best

Best ◆◆◆◆◆

best  Wood

best  LaminatedPanel abrasive

best  LaminatedPanel fine

best  Laminate

best  MultiMaterial



Expert ◆◆◆◆

expert  Wood

expert  LaminatedPanel

expert  ConstructWood

expert  HighPressureLaminate

expert  MultiMaterial

expert  Aluminium

expert  Steel

expert  SandwichPanel

expert  FiberCement

Expert
◆◆◆◆

Standard ◆◆◆

 **Optiline**
WOOD

 **Speedline**
WOOD

 **CONSTRUCT**
WOOD



 **MULTI**
MATERIAL

Expert

For perfect cuts you can rely on

Expert for Wood, Aluminium, Laminated Panel, Sandwich Panel, High Pressure Laminate, Construct Wood, Steel, Multi Material





- 
Microteq teeth
 Manufactured from extra-hard, durable carbide grains. Unique – from in-house production.
- 
Protection coating
 High-end technology coating for reliable cutting performance – prevents corrosion and reduces friction.
- 
Vibration Control
 Specially designed anti-vibration slots for particularly smooth running, considerably less noise and significantly reduced vibration.
- Steel body**
 Premium steel (up to HRC 46) for high endurance. Laser-cut for precision and no blade warping.
- Expansion slots**
 Laser-cut for high blade stability and accuracy. The special design of the slot ensures reduced noise levels.
- Tensioning ring**
 The blades remain dimensionally stable and perfectly flat, also during use, thanks to the specially rolled-in tensioning ring.

Expert 

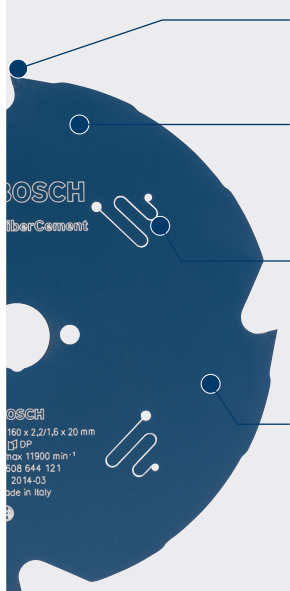
Expert for Fiber Cement



- Polycrystalline diamond teeth (PCD) for an extremely long lifetime**
- 
Protection coating
 High-end technology coating for reliable cutting performance – prevents corrosion and reduces friction.
- 
Vibration Control
 Specially designed anti-vibration slots for particularly smooth running, considerably less noise and significantly reduced vibration.
- Steel body**
 Premium steel (up to HRC 46) for high endurance. Laser-cut for high precision and no blade warping.

 **Very coarse cut**
 Fast rip cuts and cross cuts in softwood, hardwood, raw chipboards and formwork boards

 **Fine cut**
 Cross cuts in softwood, hardwood, plywood, wood core plywood, chipboards laminated on one side, and parquet

 **Coarse cut**
 Rip and cross cuts in softwood, hardwood, raw chipboards, formwork boards and plywood

 **Very fine cut**
 Cross cuts in softwood, hardwood, plywood, wood core plywood, parquet, fibre materials and MDF

Expert

For perfect cuts you can rely on

Expert for Wood, Laminated Panel



Dura Technology teeth
Manufactured from extra-hard, durable carbide grains. Unique – from in-house production.

Vibration Control
Specially designed anti-vibration slots for particularly smooth running, considerably less noise and significantly reduced vibration.

Steel body
Premium steel (up to HRC 46) for high endurance. Laser-cut for precision and no blade warping.

Expansion slots
Laser-cut for high blade stability and accuracy. The special design of the slot reduces noise levels.

Tensioning ring
The blades remain dimensionally stable and perfectly flat, also during use, thanks to the specially rolled-in tensioning ring.

Expert 

 **Very coarse cut**
Fast rip cuts and cross cuts in softwood, hardwood, raw chipboards and formwork boards

 **Coarse cut**
Rip and cross cuts in softwood, hardwood, raw chipboards, formwork boards and plywood

 **Fine cut**
Cross cuts in softwood, hardwood, plywood, wood core plywood, chipboards laminated on one side, and parquet

 **Very fine cut**
Cross cuts in softwood, hardwood, plywood, wood core plywood, parquet, fibre materials and MDF

Circular saw blades for plunge and hand-held circular saws



- For effortlessly clean cross and rip cuts in all types of wood and wood-based materials. Microteq teeth for a long lifetime.

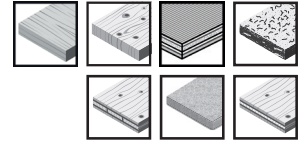

expert **for Wood**

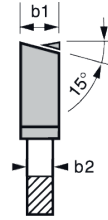
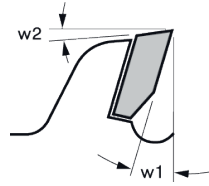

ATB
 w1: hook angle
 w2: relief angle
 b1: width of cut
 b2: base blade thickness

Outer diameter mm	Bore size mm	Width of cut (b1) mm / Base blade thickness (b2) mm	Number of teeth	Tooth shape	Cutting result	Pin hole/Pitch - circle diameter	Hook angle ° w1	Relief angle ° w2	Part number	Packaging type	Pack quantity	Minimum order quantity	Barcode 3165140...
Product properties								Ordering information					
165	20	2.6/ 1.6	48	ATB ●●●●	2/6/ 32.5	5	15	2 608 644 024	C1a	1	1	795906	
190	30	2.6/ 1.6	48	ATB ●●●●	2/7/ 42	10	15	2 608 644 049	C1a	1	1	796156	
190	30	2.6/ 1.6	56	ATB ●●●●	2/7/42	5	15	2 608 644 050	C1a	1	1	796163	
235	30	2.8/ 1.8	56	ATB ●●●●	2/7/42	10	15	2 608 644 066	C1a	1	1	796323	



Circular saw blades for plunge and hand-held circular saws



- ▶ For effortless cross and rip cuts in all types of wood and wood-based materials. Microteq teeth for a long lifetime.

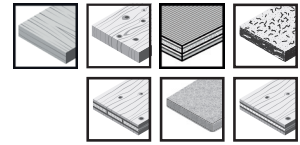

expert **40+** Wood

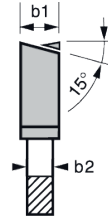
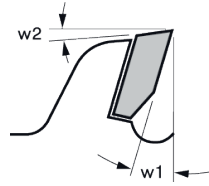

ATB
 w1: hook angle
 w2: relief angle
 b1: width of cut
 b2: base blade thickness

Outer diameter mm	Bore size mm	Width of cut (b1) mm / Base blade thickness (b2) mm	Number of teeth	Tooth shape	Cutting result	Pin hole/Pitch - circle diameter	Hook angle ° w1	Relief angle ° w2	Part number	Packaging type	Pack quantity	Minimum order quantity	Barcode 3165140...
Product properties								Ordering information					
165	20	2.6/1.6	24	ATB ●●	2/6/32.5	15	15	2 608 644 022	C1a	1	1	795883	
165	20	2.6/1.6	36	ATB ●●●	2/6/32.5	10	15	2 608 644 023	C1a	1	1	795890	
190	30	2.6/1.6	24	ATB ●●	2/7/42	15	15	2 608 644 047	C1a	1	1	796132	
190	30	2.6/1.6	40	ATB ●●●	2/7/42	10	15	2 608 644 048	C1a	1	1	796149	
235	30	2.8/1.8	36	ATB ●●●	2/7/42	15	15	2 608 644 064	C1a	1	1	796309	
235	30	2.8/1.8	48	ATB ●●●●	2/7/42	10	15	2 608 644 065	C1a	1	1	796316	



Circular saw blades for mitre saws and sliding mitre saws

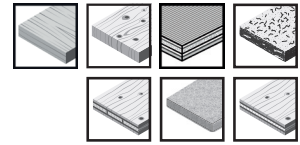

- ▶ For effortlessly clean cuts in all types of wood and wood-based materials. Microteq teeth for a long lifetime.

expert **for Wood**

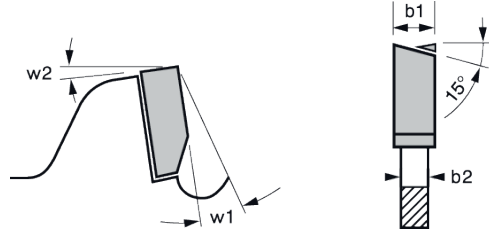

ATB
 w1: hook angle
 w2: relief angle
 b1: width of cut
 b2: base blade thickness

Product properties	Ordering information												
Outer diameter mm	Bore size mm	Width of cut (b1) mm / Base blade thickness (b2) mm	Number of teeth	Tooth shape	Cutting result	Pin hole/pitch circle diameter	Hook angle ° w1	Relief angle ° w2	Part number	Packaging type	Pack quantity	Minimum order quantity	Barcode 3163140...
210	30	2.4/1.8	48	ATB	●●	2/7/42	-5	15	2 608 642 496	C1a	1	1	648219
216	30	2.4/1.8	40	ATB	●●	2/7/42	-5	15	2 608 644 079	C1a	1	1	796453
216	30	2.4/1.8	48	ATB	●●	2/7/42	-5	15	2 608 642 497	C1a	1	1	648226
250	30	2.4/1.8	40	ATB	●●	2/7/42 2/9,5/ 46,5 2/9/46 2/10/ 60	-5	15	2 608 644 080	C1a	1	1	796460
250	30	2.4/1.8	60	ATB	●●●	2/7/42 2/9,5/ 46,5 2/9/46 2/10/ 60	-5	15	2 608 642 498	C1a	1	1	648233
254	30	2.4/1.8	60	ATB	●●●	2/7/42 2/9,5/ 46,5 2/9/46 2/10/ 60	-5	15	2 608 642 530	C1a	1	1	650120
260	30	2.4/1.8	60	ATB	●●●	2/7/42 2/9,5/ 46,5 2/9/46 2/10/ 60	-5	15	2 608 644 082	C1a	1	1	796484
300	30	2.4/1.8	72	ATB	●●●	4/12/ 64; 2/9/55	-5	15	2 608 642 499	C1a	1	1	648240
305	30	2.4/1.8	72	ATB	●●●	2/7/42 2/9,5/ 46,5 2/9/46 2/10/ 60	-5	15	2 608 642 531	C1a	1	1	650137
315	30	2.4/1.8	72	ATB	●●●●	2/7/42 2/9,5/ 46,5 2/9/46 2/10/ 60	-5	15	2 608 644 081	C1a	1	1	796477



Circular saw blades for table saws

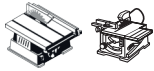

- For effortlessly clean cuts in all types of wood and wood-based materials. Microteq teeth for a long lifetime.

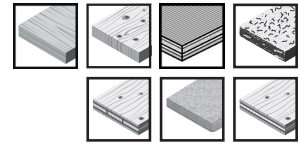

expert **401** Wood

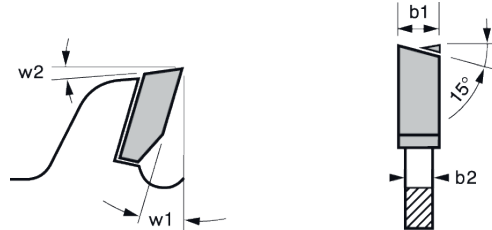

ATB
 w1: hook angle
 w2: relief angle
 b1: width of cut
 b2: base blade thickness

Outer diameter mm	Bore size mm	Width of cut (b1) mm / Base blade thickness (b2) mm	Number of teeth	Tooth shape	Cutting result	Pin hole/Pitch circle diameter	Hook angle ° w1	Relief angle ° w2	Part number	Packaging type	Pack quantity	Minimum order quantity	Barcode 3165-140...
Product properties								Ordering information					
250	30	2.5/ 1.8	80	ATB ●●●●	2/7/42 2/9,5/ 46,5 2/9/46 2/10/ 60	5	15	2 608 642 500	C1a	1	1	648257	
300	30	2.5/ 1.8	100	ATB ●●●●	2/7/42 2/9,5/ 46,5 2/9/46 2/10/ 60	5	15	2 608 642 501	C1a	1	1	648264	
190	30	2.0/ 1.3	24	ATB ●●	2/7/42	15	15	2 608 644 083	C1a	1	1	796491	
190	30	2.0/ 1.3	40	ATB ●●●	2/7/42	10	15	2 608 644 084	C1a	1	1	796507	
190	30	2.0/ 1.3	48	ATB ●●●●	2/7/42	5	15	2 608 644 085	C1a	1	1	796514	
190	Star	2.4/ 1.6	24	ATB ●●	-	15	15	2 608 644 086	C1a	1	1	796521	
190	Star	2.4/ 1.6	48	ATB ●●●●	-	5	15	2 608 644 087	C1a	1	1	796538	
220	30	2.6/ 1.6	48	ATB ●●●●	2/7/42	10	15	2 608 644 088	C1a	1	1	796545	
225	30	2.6/ 1.6	32	ATB ●●●	2/7/42	15	15	2 608 644 089	C1a	1	1	796552	
225	30	2.6/ 1.6	48	ATB ●●●●	2/7/42	10	15	2 608 644 090	C1a	1	1	796569	
260	30	2.8/ 1.8	80	ATB ●●●●	2/7/42 2/9,5/ 46,5 2/9/46 2/10/ 60	10	15	2 608 644 091	C1a	1	1	796576	

Expert
 ★★★★★

Circular saw blades for horizontal/vertical panel sizing and table saws

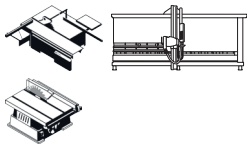
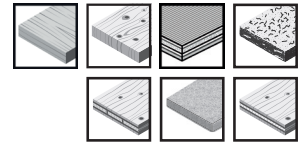

► Long life and constantly high cut quality in all types of wood and wood-based materials.

expert **for Wood**

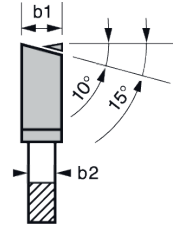
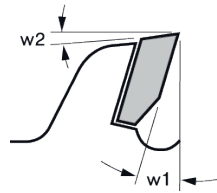

ATB
 w1: hook angle
 w2: relief angle
 b1: width of cut
 b2: base blade thickness

Outer diameter mm	Bore size mm	Width of cut (b1) mm / Base blade thickness (b2) mm	Number of teeth	Tooth shape	Cutting result	Pin hole/pitch circle diameter	Hook angle ° w1	Relief angle ° w2	Part number	Packaging type	Pack quantity	Minimum order quantity	Barcode 3165140...
Product properties								Ordering information					
250	30	3.2/ 2.2	22	ATB	●● 2/7/42 2/9/ 46.4 2/10/ 60	20	15		2 608 642 502*	C1c	1	1	648271
300	30	3.2/ 2.2	26	ATB	●● 2/7/42 2/9/ 46.4 2/10/ 60	20	15		2 608 642 503*	C1c	1	1	648288
350	30	3.5/ 2.5	30	ATB	●● 2/7/42 2/9/ 46.4 2/10/ 60	20	15		2 608 642 504*	C1c	1	1	648295
250	30	3.2/ 2.2	40	ATB	●● 2/7/42 2/9/ 46.4 2/10/ 60	15	15		2 608 642 505	C1c	1	1	648301
250	30	3.2/ 2.2	60	ATB	●●● 2/7/42 2/9/ 46.4 2/10/ 60	10	15		2 608 642 506	C1c	1	1	648318
250	30	3.2/ 2.2	80	ATB	●●●● 2/7/42 2/9/ 46.4 2/10/ 60	5	18		2 608 642 507	C1c	1	1	648325

* Ripping saw blades



Circular saw blades for horizontal/vertical panel sizing and table saws

Outer diameter mm		Bore size mm		Width of cut (b1) mm / Base blade thickness (b2) mm		Number of teeth		Tooth shape		Cutting result		Pin hole/Pitch circle diameter		Hook angle ° w1		Relief angle ° w2		Part number		Packaging type		Pack quantity		Minimum order quantity		BarCode 3165140...	
Product properties															Ordering information												
300	30	3.2/2.2	48	ATB	●●	2/7/42 2/9/ 46.4 2/10/ 60	15	15	2 608 642 508	C1c	1	1	648332														
300	30	3.2/2.2	60	ATB	●●●	2/7/42 2/9/ 46.4 2/10/ 60	10	15	2 608 642 509	C1c	1	1	648349														
300	30	3.2/2.2	72	ATB	●●●	2/7/42 2/9/ 46.4 2/10/ 60	10	15	2 608 642 510	C1c	1	1	648356														
300	30	3.2/2.2	96	ATB	●●●●	2/7/42 2/9/ 46.4 2/10/ 60	5	18	2 608 642 511	C1c	1	1	648363														
350	30	3.5/2.5	54	ATB	●●●	2/7/42 2/9/ 46.4 2/10/ 60	15	15	2 608 642 512	C1c	1	1	648370														
350	30	3.5/2.5	72	ATB	●●●	2/7/42 2/9/ 46.4 2/10/ 60	10	15	2 608 642 513	C1c	1	1	648387														



Circular saw blades for plunge and hand-held circular saws

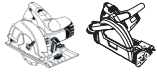

- ▶ The special tooth design and the wide support in the tooth spine ensure high resistance and cut construction site timber with foreign bodies such as nails and concrete residues. Also suitable for cutting formwork boards, raw chipboard, acoustic panels, lightweight building panels and aerated concrete. Microteq teeth for a long lifetime.

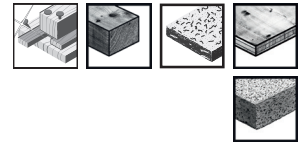

expert **ConstructWood**

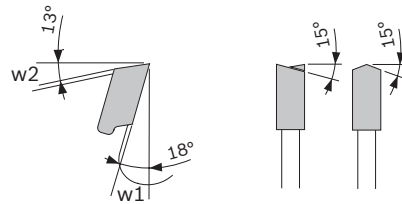

ATB+Pyramid
 w1: hook angle
 w2: relief angle

Outer diameter mm		Bore size mm		Width of cut (b1) mm / Base blade thickness (b2) mm		Number of teeth		Tooth shape		Cutting result		Pin hole/Pitch circle diameter		Hook angle ° w1		Relief angle ° w2		Part number		Packaging type		Pack quantity		Minimum order quantity		Barcode 3163140...	
Product properties														Ordering information													
165	20	2.0/1.3	24	ATB+Pyramid	●●	2/6/32.5	18	13	2 608 644 137	C1a	1	1	797030														
190	30	2.0/1.3	24	ATB+Pyramid	●●	2/7/42	18	13	2 608 644 139	C1a	1	1	797054														



Circular saw blades for plunge and hand-held circular saws

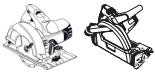
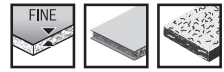

- For effortlessly clean cuts in panel materials (laminated on one or two sides), abrasive panels, and fine-coated or veneered panels. Also suitable for cutting raw chipboard, acoustic panels and lightweight building panels. Microteq teeth for a long lifetime.

expert **for Laminated Panel**

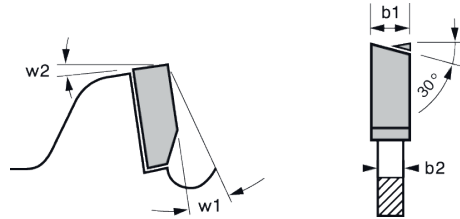

ATB
 w1: hook angle
 w2: relief angle
 b1: width of cut
 b2: base blade thickness

Product properties										Ordering information				
Outer diameter mm	Bore size mm	Width of cut (b1) mm / Base blade thickness (b2) mm	Number of teeth	Tooth shape	Cutting result	Pin hole/Pitch circle diameter	Hook angle ° w1	Relief angle ° w2	Part number	Packaging type	Pack quantity	Minimum order quantity	Barcode 3163140...	
165	20	2.6/1.6	48	ATB ●●●●	2/6/32.5	-5	15		2 608 644 128	C1a	1	1	796941	
190	30	2.6/1.6	60	ATB ●●●●	2/7/42	-5	15		2 608 644 130	C1a	1	1	796965	



Circular saw blades for horizontal/vertical panel sizing and table saws

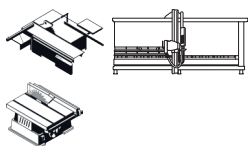
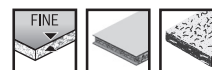

- ▶ Long life and constantly high cut quality in panels coated on one or two sides.

DH: Scoring blade not required when used on panel sizing saws.

expert **LaminatedPanel**

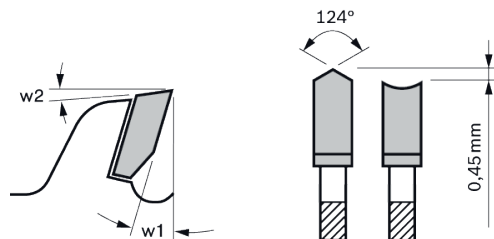

DH
w1: hook angle
w2: relief angle

Outer diameter mm	Bore size mm	Width of cut (b1) mm / Base blade thickness (b2) mm	Number of teeth	Tooth shape	Cutting result	Pin hole/pitch circle diameter	Hook angle ° w1	Relief angle ° w2	Part number	Packaging type	Pack quantity	Minimum order quantity	Barcode 3165140...
Product properties					Ordering information								
250	30	3.2/ 2.2	48	DH ●●●	2/7/42 2/9/ 46.4 2/10/ 60	10	15	2 608 642 514	C1c	1	1	648394	
303	30	3.2/ 2.2	60	DH ●●●	2/7/42 2/9/ 46.4 2/10/ 60	10	15	2 608 642 515	C1c	1	1	648400	

Circular saw blades for horizontal/vertical panel sizing and table saws

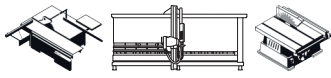
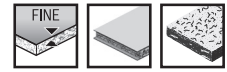

expert **100** LaminatedPanel

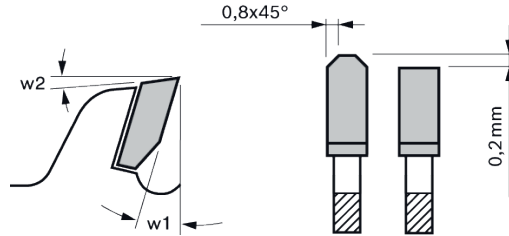

HLTCG
w1: hook angle
w2: relief angle

Outer diameter mm	Bore size mm	Width of cut (b1) mm / Base blade thickness (b2) mm	Number of teeth	Tooth shape	Cutting result	Pin hole/pitch circle diameter	Hook angle ° w1	Relief angle ° w2	Part number	Packaging type	Pack quantity	Minimum order quantity	Barcode 3165140...
Product properties							Ordering information						
250	30	3.2/ 2.2	80	HLTCG	●●●●	2/7/42 2/9/ 46.4 2/10/ 60	5	18	2 608 642 516	C1c	1	1	648417
300	30	3.2/ 2.2	96	HLTCG	●●●●	2/7/42 2/9/ 46.4 2/10/ 60	5	18	2 608 642 517	C1c	1	1	648424
350	30	3.5/ 2.5	108	HLTCG	●●●●	2/7/42 2/9/ 46.4 2/10/ 60	5	18	2 608 642 518	C1c	1	1	648431



Circular saw blades for plunge and hand-held circular saws

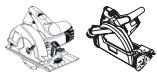

- For clean cuts in High Pressure Laminate panels. Suitable for cutting Trespa® panels. Microteq teeth for a long lifetime.

expert HighPressureLaminate

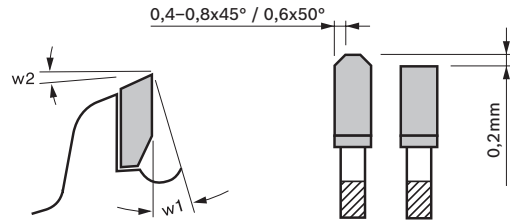

HLTCG
w1: hook angle
w2: relief angle

Outer diameter mm		Bore size mm		Width of cut (b1) mm / Base blade thickness (b2) mm		Number of teeth		Tooth shape		Cutting result		Pin hole / Pitch circle diameter		Hook angle ° w1		Relief angle ° w2		Part number		Packaging type		Pack quantity		Minimum order quantity		Barcode 3165140...	
Product properties														Ordering information													
165	20	2.6/1.6	48	HLTCG	●●●●	2/6/32.5	0	17	2 608 644 133*	C1a	1	1	796996														
190	30	2.6/1.6	56	HLTCG	●●●●	2/7/42	0	17	2 608 644 135*	C1a	1	1	797016														

* Available from 09/2014



Circular saw blades for mitre saws and sliding mitre saws

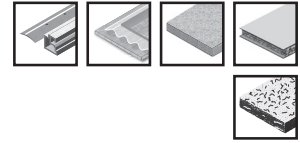

- For excellent results in non-ferrous metals, aluminium, plastics, epoxy and wood.

expert **MultiMaterial**

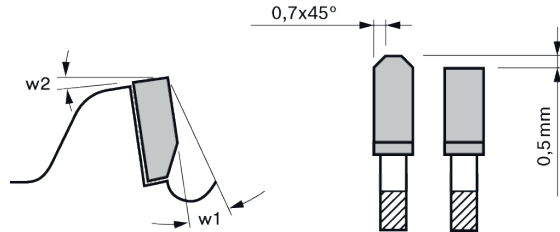

TCG
w1: hook angle
w2: relief angle

Outer diameter mm	Bore size mm	Width of cut (b1) mm / Base blade thickness (b2) mm	Number of teeth	Tooth shape	Cutting result	Hook angle ° w1	Relief angle ° w2	Part number	Packaging type	Pack quantity	Minimum order quantity	Barcode 3165140...
Product properties								Ordering information				
210	30	2.4/1.8	54	TCG	●●●	-5	-	2 608 642 492	C1a	1	1	648172
216	30	2.4/1.8	64	TCG	●●●	-5	-	2 608 642 493	C1a	1	1	648189
250	30	2.4/1.8	80	TCG	●●●●	-5	-	2 608 642 494	C1a	1	1	648196
254	30	2.4/1.8	80	TCG	●●●●	-5	-	2 608 642 528	C1a	1	1	650106
300	30	2.4/1.8	96	TCG	●●●●	-5	-	2 608 642 495	C1a	1	1	648202
305	30	2.4/1.8	96	TCG	●●●●	-5	-	2 608 642 529	C1a	1	1	650113



Circular saw blades for mitre saws and sliding mitre saws

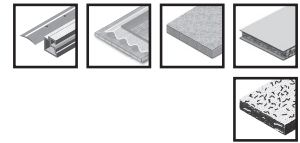

- ▶ For clean cuts in non-ferrous metals such as aluminium. Also suitable for cutting plastics and epoxy, raw chipboard, acoustic panels, lightweight building panels, abrasive panel materials laminated on one or two sides, and fibre materials such as MDF and OSB boards. Microteq teeth for a long lifetime.
- ▶ Using the universal cutting oil 2 607 001 409 increases the lifetime several times over when cutting in metal, e.g. aluminium.

expert **FOR Aluminium**

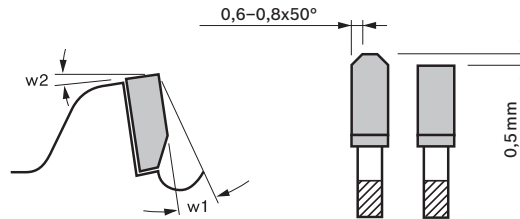

HLTCG
 w1: hook angle
 w2: relief angle

Outer diameter mm	Bore size mm	Width of cut (b1) mm / Base blade thickness (b2) mm	Number of teeth	Tooth shape	Cutting result	Pin hole / Pitch circle diameter	Hook angle ° w1	Relief angle ° w2	Part number	Packaging type	Pack quantity	Minimum order quantity	Barcode 3165140...
210	30	2.6/ 1.8	54	HLTCG	●●●	2/7/42 2/9,5/ 46,5 2/9/46 2/10/ 60	-5	15	2 608 644 109	C1a	1	1	796750
216	30	2.6/ 1.8	64	HLTCG	●●●	2/7/42 2/9,5/ 46,5 2/9/46 2/10/ 60	-5	15	2 608 644 110	C1a	1	1	796767

Circular saw blades for mitre saws and sliding mitre saws

Outer diameter mm	Bore size mm	Width of cut (b1) mm / Base blade thickness (b2) mm	Number of teeth	Tooth shape	Cutting result	Pin hole/Pitch circle diameter	Hook angle ° w1	Relief angle ° w2	Part number	Packaging type	Pack quantity	Minimum order quantity	Barcode 3163140...
Product properties									Ordering information				
250	30	2.8/ 2.0	80	HLTCG	●●●	2/7/42 2/9,5/ 46,5 2/9/46 2/10/ 60	-5	15	2 608 644 111	C1a	1	1	796774
254	30	2.8/ 2.0	80	HLTCG	●●●●	2/7/42 2/9,5/ 46,5 2/9/46 2/10/ 60	-5	15	2 608 644 112	C1a	1	1	796781
260	30	2.8/ 2.0	80	HLTCG	●●●●	2/7/42 2/9,5/ 46,5 2/9/46 2/10/ 60	-5	15	2 608 644 113	C1a	1	1	796798
300	30	2.8/ 2.0	96	HLTCG	●●●●	2/7/42 2/9,5/ 46,5 2/9/46 2/10/ 60	-5	15	2 608 644 114	C1a	1	1	796804
305	30	2.8/ 2.0	96	HLTCG	●●●●	2/7/42 2/9,5/ 46,5 2/9/46 2/10/ 60	-5	15	2 608 644 115	C1a	1	1	796811
315	30	2.8/ 2.2	96	HLTCG	●●●●	2/7/42 2/9,5/ 46,5 2/9/46 2/10/ 60	-5	15	2 608 644 116	C1a	1	1	796828



Circular saw blades for table saws

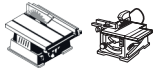

- ▶ For clean cuts in non-ferrous metals such as aluminium. Also suitable for cutting plastics and epoxy, raw chipboard, acoustic panels, lightweight building panels, abrasive panel materials laminated on one or two sides, and fibre materials such as MDF and OSB boards. Microteq teeth for a long lifetime.
- ▶ Using the universal cutting oil 2 607 001 409 increases the lifetime several times over when cutting in metal, e.g. aluminium.

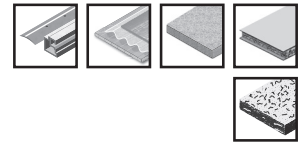

expert **Aluminium**

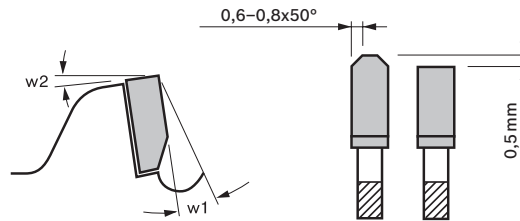

HLTCG
w1: hook angle
w2: relief angle

Outer diameter mm	Bore size mm	Width of cut (b1) mm / Base blade thickness (b2) mm	Number of teeth	Tooth shape	Cutting result	Pin hole/pitch circle diameter	Hook angle ° w1	Relief angle ° w2	Part number	Packaging type	Pack quantity	Minimum order quantity	Barcode 3163140...
190	Star	2.6/ 1.8	58	HLTCG	●●●●	-	-5	15	2 608 644 117	C1a	1	1	796835
225	30	2.6/ 1.8	68	HLTCG	●●●●	2/7/42 2/9,5/ 46,5 2/9/46 2/10/ 60	-5	15	2 608 644 118	C1a	1	1	796842
250	30	2.8/ 2.0	68	HLTCG	●●●●	2/7/42 2/9,5/ 46,5 2/9/46 2/10/ 60	-5	15	2 608 644 119	C1a	1	1	796859

Circular saw blades for Hand Dry Cutters



► Very long lifetime. For clean cuts through steel using Hand Dry Cutters.

expert **for Steel**

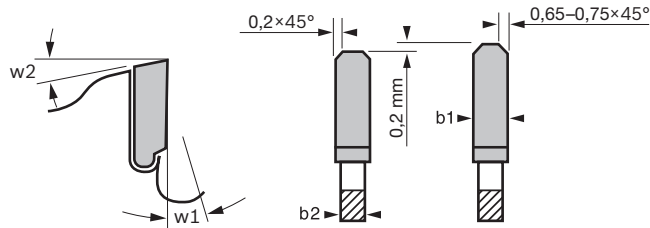

HLTCG
 w1: hook angle
 w2: relief angle
 b1: width of cut
 b2: base blade thickness

Outer diameter mm	Bore size mm	Width of cut (b1) mm / Base blade thickness (b2) mm	Number of teeth	Tooth shape	Cutting result	Pin hole/Pitch circle diameter	Hook angle ° w1	Relief angle ° w2	Part number	Packaging type	Pack quantity	Minimum order quantity	Barcode 3165140...
Product properties							Ordering information						
160	20	2.0/ 1.6	30	HLTCG	●●	-	0	12	2 608 643 054	C1a	1	1	737678
184	20	2.0/ 1.6	48	HLTCG	●●●	-	0	12	2 608 643 055	C1a	1	1	737685
190	20	2.0/ 1.6	40	HLTCG	●●●	-	0	12	2 608 643 056	C1a	1	1	737692
210	30	2.0/ 1.6	48	HLTCG	●●●	-	0	12	2 608 643 057	C1a	1	1	737708
230	25.4	2.0/ 1.6	48	HLTCG	●●●	-	0	12	2 608 643 058	C1a	1	1	737715

Circular saw blades for Mitre Dry Cutters



► Very long lifetime. For clean cuts through steel using Mitre Dry Cutters.

expert **for Steel**

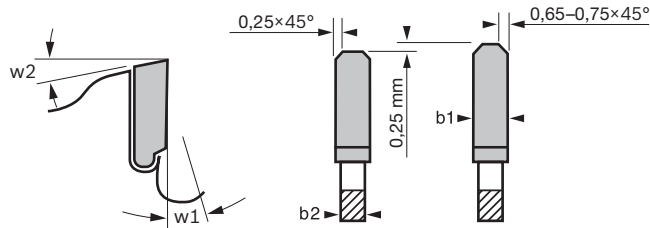

HLTCG
 w1: hook angle
 w2: relief angle
 b1: width of cut
 b2: base blade thickness

Outer diameter mm		Bore size mm		Width of cut (b1) mm / Base blade thickness (b2) mm		Number of teeth		Tooth shape		Cutting result		Pin hole/Pitch circle diameter		Hook angle ° w1		Relief angle ° w2		Part number		Packaging type		Pack quantity		Minimum order quantity		Barcode 3165140...		
Product properties														Ordering information														
254	25.4	2.6/2.2	60	HLTCG	●●●●	-	0	12	2 608 643 059	C1a	1	1	737722															
305	25.4	2.6/2.2	60	HLTCG	●●●●	-	0	12	2 608 643 060	C1a	1	1	737739															
305	25.4	2.6/2.2	80	HLTCG	●●●●	-	0	12	2 608 643 061	C1a	1	1	737746															
355	25.4	2.6/2.2	80	HLTCG	●●●●	-	0	12	2 608 643 062	C1a	1	1	737753															
355	25.4	2.6/2.2	90	HLTCG	●●●●	-	0	12	2 608 643 063	C1a	1	1	737760															



Circular saw blades for plunge and hand-held circular saws

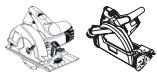

- For clean cuts in sandwich panels with sheet steel (laminated on one or two sides). Microteq teeth for a long lifetime.

expert **for SandwichPanel**

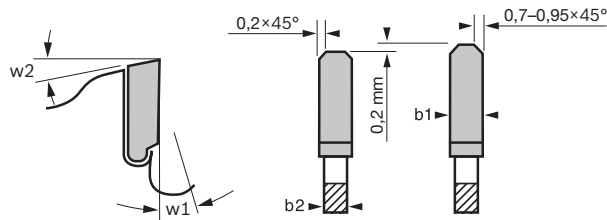

HLTCG
 w1: hook angle
 w2: relief angle
 b1: width of cut
 b2: base blade thickness

Product properties										Ordering information			
Outer diameter mm	Bore size mm	Width of cut (b1) mm / Base blade thickness (b2) mm	Number of teeth	Tooth shape	Cutting result	Pin hole/pitch circle diameter	Hook angle ° w1	Relief angle ° w2	Part number	Packaging type	Pack quantity	Minimum order quantity	Barcode 3165140...
235	30	2.2/1.8	50	HLTCG	●●●●	2/7/42	0	10	2 608 644 143*	C1a	1	1	797092

* Available from 03/2015

Circular saw blades for plunge and hand-held circular saws

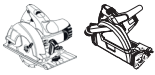
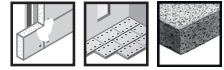

- For cuts in fibre cement and plasterboard. Suitable for Eternit®. Polycrystalline diamond teeth for an extremely long lifetime.

expert **FiberCement**

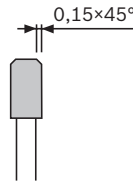
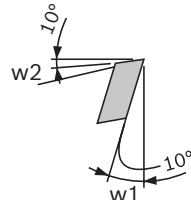

TCG
w1: hook angle
w2: relief angle

Product properties										Ordering information				
Outer diameter mm	Bore size mm	Width of cut (b1) mm / Base blade thickness (b2) mm	Number of teeth	Tooth shape	Cutting result	Pin hole/pitch circle diameter	Hook angle ° w1	Relief angle ° w2	Part number	Packaging type	Pack quantity	Minimum order quantity	Barcode 3165140...	
165	20	2.2/ 1.6	4	TCG	●●	2/6/ 32.5	10	10	2 608 644 122	C1a	1	1	796880	
190	30	2.2/ 1.6	4	TCG	●●	2/7/ 42	10	10	2 608 644 125	C1a	1	1	796910	



Best ◆◆◆◆◆

► Page 12

best  **Wood**

best  **LaminatedPanel** abrasive

best  **LaminatedPanel** fine

best  **Laminate**

best  **MultiMaterial**

Expert ◆◆◆◆◆

► Page 21

expert  **Wood**

expert  **LaminatedPanel**

expert  **ConstructWood**

expert  **HighPressureLaminate**

expert  **MultiMaterial**

expert  **Aluminium**

expert  **Steel**

expert  **SandwichPanel**

expert  **FiberCement**

Standard
◆◆◆

Standard ◆◆◆

 **optiline**
WOOD

 **speedline**
WOOD

 **CONSTRUCT**
WOOD

 **MULTI**
MATERIAL



 **BOSCH**

standard  **Wood**

Standard

The ideal line for optimum cuts

Standard for Optiline Wood, Speedline Wood, Construct Wood, Multi Material

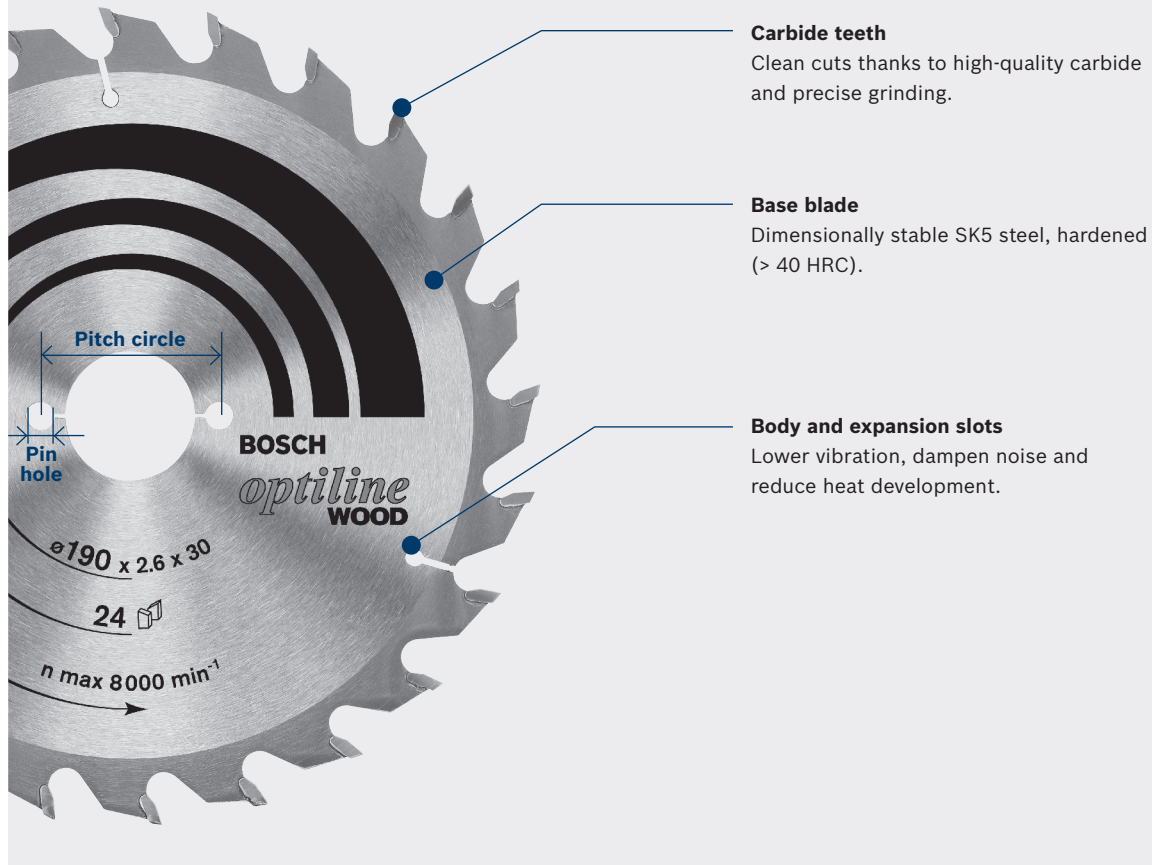

Standard 

 **Very coarse cut**
Fast rip cuts and cross cuts in softwood, hardwood, raw chipboards and formwork boards

 **Coarse cut**
Rip and cross cuts in softwood, hardwood, raw chipboards, formwork boards and plywood

 **Fine cut**
Cross cuts in softwood, hardwood, plywood, wood core plywood, chipboards laminated on one side, and parquet

 **Very fine cut**
Cross cuts in softwood, hardwood, plywood, wood core plywood, parquet, fibre materials and MDF

Optiline Wood for hand-held circular saws



► The precise blade for quality cuts in all types of wood.

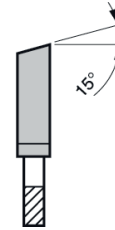
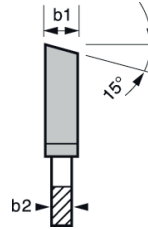
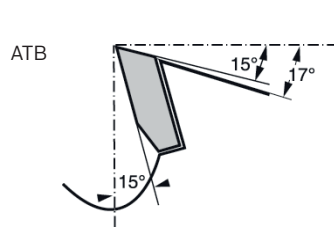
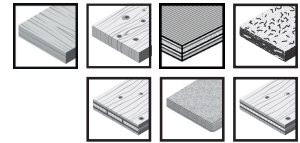

b1: width of cut
b2: base blade thickness

Standard
◆◆◆

Outer diameter mm	Bore size mm	Bore with reduction ring mm	Width of cut (b1) mm / Base blade thickness (b2) mm	Number of teeth	Cutting result	Tooth shape	Pin hole/pitch circle diameter	Part number	Packaging type	Pack quantity	Minimum order quantity	Barcode 3163140...
Product properties						Ordering information						
85	15	- 1.1/0.7	20	●●●	ATB	-		2 608 643 071	C1a	1	1	754279
130	20	16 2.4/1.4	12	●	ATB	-		2 608 641 167	C1a	1	1	373494
130	20	16 2.4/1.4	20	●●	ATB	-		2 608 640 582	C1a	1	1	193764
130	20	16 2.4/1.4	30	●●●	ATB	-		2 608 640 583	C1a	1	1	193771
140	20	12.7 2.4/1.4	12	●	ATB	-		2 608 641 168	C1a	1	1	373500
140	20	12.7 2.4/1.4	20	●●	ATB	-		2 608 640 586	C1a	1	1	193801
150	20	16 2.4/1.4	12	●	ATB	7/42		2 608 641 169	C1a	1	1	373517
150	20	16 2.4/1.4	24	●●	ATB	7/42		2 608 640 592	C1a	1	1	193863
150	20	16 2.4/1.4	36	●●●	ATB	7/42		2 608 640 593	C1a	1	1	193870
160	20	16 1.8/1.2	12	●	ATB	6/32		2 608 641 170*	C1a	1	1	373524
160	20	16 1.8/1.2	24	●●	ATB	6/32		2 608 641 171*	C1a	1	1	373531
160	20	16 1.8/1.2	48	●●●●	ATB	6/32		2 608 641 172*	C1a	1	1	373548
160	20	16 2.6/1.6	12	●	ATB	6/32		2 608 641 173	C1a	1	1	373555
160	20	16 2.6/1.6	24	●●	ATB	6/32		2 608 640 596	C1a	1	1	193900
160	20	16 2.6/1.6	36	●●●	ATB	6/32		2 608 640 597	C1a	1	1	193917
160	20	16 2.6/1.6	48	●●●●	ATB	6/32		2 608 640 732	C1a	1	1	195072
165	30	- 2.6/1.6	24	●	ATB	-		2 608 640 602	C1a	1	1	193962
165	20	16 1.7/1.2	36	●●●	ATB	-		2 608 642 602	C1a	1	1	660273
165	30	- 2.6/1.6	36	●●●	ATB	-		2 608 640 603	C1a	1	1	193979
165	30	- 2.6/1.6	48	●●●●	ATB	-		2 608 641 175	C1a	1	1	373579
180	30	20 2.6/1.6	24	●●	ATB	-		2 608 640 608	C1a	1	1	194020
180	30	20 2.6/1.6	36	●●●	ATB	-		2 608 640 609	C1a	1	1	194037
184	16	- 2.6/1.6	24	●●	ATB	-		2 608 640 817	C1a	1	1	263429
184	16	- 2.6/1.6	36	●●●	ATB	-		2 608 640 818	C1a	1	1	263436
184	16	- 2.6/1.6	48	●●●●	ATB	-		2 608 641 181	C1a	1	1	373630
184	30	- 2.6/1.6	24	●●	ATB	-		2 608 640 610	C1a	1	1	194044
184	30	- 2.6/1.6	36	●●●	ATB	-		2 608 640 611	C1a	1	1	194051
190	20	16 2.6/1.6	24	●●	ATB	-		2 608 640 612	C1a	1	1	194068
190	20	16 2.6/1.6	36	●●●	ATB	-		2 608 640 613	C1a	1	1	194075
190	20	16 2.6/1.6	48	●●●●	ATB	-		2 608 640 614	C1a	1	1	194082
190	30	- 2.0/1.3	16	●	ATB	7/42		2 608 641 184*	C1a	1	1	373661
190	30	- 2.0/1.3	24	●●	ATB	7/42		2 608 641 185*	C1a	1	1	373678
190	30	- 2.0/1.3	48	●●●●	ATB	7/42		2 608 641 186*	C1a	1	1	373685
190	30	- 2.6/1.6	12	●	ATB	7/42		2 608 641 187	C1a	1	1	373692
190	30	- 2.6/1.6	24	●●	ATB	7/42		2 608 640 615	C1a	1	1	194099
190	30	- 2.6/1.6	36	●●●	ATB	7/42		2 608 640 616	C1a	1	1	194105
190	30	- 2.6/1.6	48	●●●●	ATB	7/42		2 608 640 617	C1a	1	1	194112
190	30	- 2.6/1.6	60	●●●●	ATB	7/42		2 608 641 188	C1a	1	1	373708
200	30	- 2.8/1.8	24	●●	ATB	7/42		2 608 640 618	C1a	1	1	194129

* For an extra-thin cut with little exertion of force. Also especially suitable for cordless circular saws.

Optiline Wood for hand-held circular saws

Outer diameter mm		Bore size mm		Bore with reduction ring mm		Width of cut (b1) mm / Base blade thickness (b2) mm		Number of teeth		Cutting result		Tooth shape		Pin hole/pitch circle diameter		Part number		Packaging type		Pack quantity		Minimum order quantity		Barcode 3163140...	
Product properties														Ordering information											
200	30	- 2.8/1.8	48	●●●●	ATB	7/42	2 608 640 620	C1a	1	1	194143														
210	30	- 2.8/1.8	24	●●	ATB	-	2 608 640 621	C1a	1	1	194150														
210	30	- 2.8/1.8	36	●●●	ATB	-	2 608 640 622	C1a	1	1	194167														
210	30	- 2.8/1.8	48	●●●●	ATB	-	2 608 640 623	C1a	1	1	194174														
210	30	- 2.8/1.8	60	●●●●	ATB	-	2 608 641 190	C1a	1	1	373722														
230	30	- 2.8/1.8	24	●●	ATB	7/42	2 608 640 627	C1a	1	1	194211														
230	30	- 2.8/1.8	36	●●●	ATB	7/42	2 608 640 628	C1a	1	1	195157														
230	30	- 2.8/1.8	48	●●●●	ATB	7/42	2 608 640 629	C1a	1	1	194228														
235	30	25 2.8/1.8	24	●●	ATB	-	2 608 640 725	C1a	1	1	194990														
235	30	25 2.8/1.8	48	●●●●	ATB	-	2 608 640 727	C1a	1	1	195010														
235	30	25 2.8/1.8	60	●●●●	ATB	-	2 608 641 192	C1a	1	1	373746														
250	30	- 3.2/2.2	40	●●●	ATB	7/42	2 608 640 728	C1a	1	1	195027														
250	30	- 3.2/2.2	60	●●●●	ATB	7/42	2 608 640 729	C1a	1	1	195034														

Standard



Optiline Wood for mitre saws

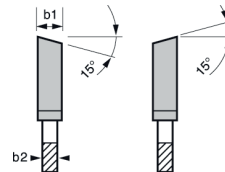
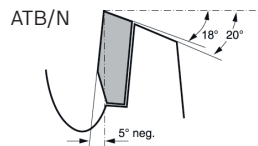
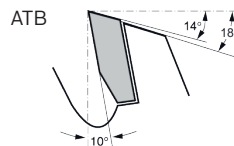

b1: width of cut
b2: base blade thickness

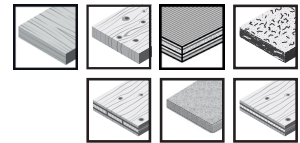

Outer diameter mm		Bore size mm		Width of cut (b1) mm / Base blade thickness (b2) mm		Number of teeth		Cutting result		Tooth shape		Pin hole/pitch circle diameter		Part number		Packaging type		Pack quantity		Minimum order quantity		Barcode 3163140...	
Product properties														Ordering information									
210	30	2.0/1.4	48	●●	ATB	-	2 608 640 430*	C1a	1	1	314398												
216	30	2.0/1.4	24	●	ATB	-	2 608 640 431*	C1a	1	1	314404												
216	30	2.0/1.4	48	●●	ATB	-	2 608 640 432*	C1a	1	1	314411												
216	30	2.0/1.4	60	●●●	ATB	-	2 608 640 433*	C1a	1	1	314428												
216	30	2.8/1.8	48	●●	ATB	-	2 608 640 641	C1a	1	1	194327												
216	30	2.8/1.8	60	●●●	ATB	-	2 608 640 642	C1a	1	1	194334												
250	30	3.2/2.2	40	●●	ATB	7/42	2 608 640 643	C1a	1	1	194341												
250	30	3.2/2.2	60	●●●	ATB	7/42	2 608 640 644	C1a	1	1	194358												
250	30	3.2/2.2	80	●●●●	ATB	7/42	2 608 640 645	C1a	1	1	194365												
254	30	2.0/1.4	24	●	ATB	-	2 608 640 434*	C1a	1	1	314435												
254	30	2.0/1.4	40	●●	ATB	-	2 608 640 438*	C1a	1	1	314473												
254	30	2.0/1.4	40	●●	ATB	-	2 608 640 435*	C1a	1	1	314442												
254	30	2.0/1.4	60	●●●	ATB	-	2 608 640 436*	C1a	1	1	314459												
254	30	2.5/1.8	80	●●●●	ATB	-	2 608 640 437	C1a	1	1	314466												
254	30	2.8/1.8	40	●●	ATB	-	2 608 640 443	C1a	1	1	317412												

* For an extra-thin cut with little exertion of force. Also especially suitable for cordless circular saws.

Optiline Wood for mitre saws

Outer diameter mm	Bore size mm	Width of cut (b1) mm / Base blade thickness (b2) mm	Number of teeth	Cutting result	Tooth shape	Pin hole/Pitch circle diameter	Part number	Packaging type	Pack quantity	Minimum order quantity	Barcode 3165140...
Product properties						Ordering information					
254	30	2.8/1.8	60	●●●	ATB	-	2 608 640 444	C1a	1	1	317429
254	30	3.2/2.2	60	●●●	ATB	-	2 608 641 765	C1a	1	1	455534
260	30	3.2/2.2	48	●●	ATB	-	2 608 641 202	C1a	1	1	373845
305	30	2.5/1.8	40	●●	ATB	-	2 608 640 440*	C1a	1	1	317382
305	30	2.5/1.8	60	●●●	ATB	-	2 608 640 441*	C1a	1	1	317399
305	30	2.5/1.8	96	●●●●	ATB	-	2 608 640 442*	C1a	1	1	317405
305	30	3.2/2.2	60	●●●	ATB	7/42 10/60	2 608 641 768	C1a	1	1	455565
305	30	3.2/2.2	80	●●●●	ATB	-	2 608 641 769	C1a	1	1	455572



* For an extra-thin cut with little exertion of force. Also especially suitable for cordless circular saws.



Optiline Wood for table saws



- ▶ UW: universal alternate top bevel tooth
- KW: plastic alternate top bevel tooth
- VW: alternate top bevel tooth design with many teeth

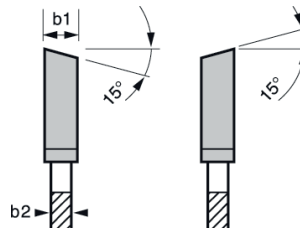
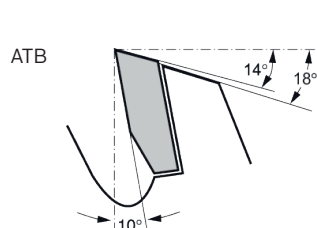
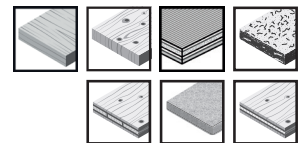

b1: width of cut
b2: base blade thickness

Outer diameter mm	Bore size mm	Width of cut (b1) mm / Base blade thickness (b2) mm	Number of teeth	Cutting result	Model	Part number	Packaging type	Pack quantity	Minimum order quantity	Barcode 3165140...
Product properties					Ordering information					
250	30	3.2/2.2	40	●●	UW	2 608 640 670	C1a	1	1	194587
250	30	3.2/2.2	60	●●●	KW	2 608 640 665	C1a	1	1	194532
250	30	3.2/2.2	80	●●●●	VW	2 608 640 660	C1a	1	1	194501
300	30	3.2/2.2	48	●●	UW	2 608 640 672	C1a	1	1	194600
305	30	3.2/2.2	72	●●●●	UW	2 608 641 771	C1a	1	1	455596
315	30	3.2/2.2	48	●●	UW	2 608 640 673	C1a	1	1	194617
315	30	3.2/2.2	60	●●●	-	2 608 640 651	C1a	1	1	194440
350	30	3.5/2.5	54	●●●	UW	2 608 640 674	C1a	1	1	194624
400	30	3.5/2.5	60	●●●	UW	2 608 640 675	C1a	1	1	194631



Speedline Wood for hand-held circular saws

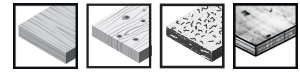

- The fast blade for cuts along and across all types of wood.

speedline
WOOD

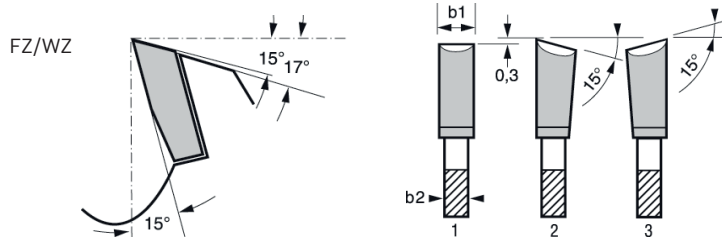

b1: width of cut
b2: base blade thickness

Outer diameter mm	Bore size mm	Bore inch	Bore with reduction ring mm	Width of cut (b1) mm / Base blade thickness (b2) mm	Number of teeth	Cutting result	Tooth shape	Part number	Packaging type	Pack quantity	Minimum order quantity	Barcode 3163140...
Product properties							Ordering information					
130	16	-	- 2.2/1.4	9	● FZ/WZ	2 608 640 774	C1a	1	1	239851		
130	16	-	- 2.2/1.4	18	●● FZ/WZ	2 608 640 775	C1a	1	1	239868		
150	20	-	- 2.2/1.4	18	●● FZ/WZ	2 608 640 781	C1a	1	1	239929		
160	16	-	- 2.4/1.6	12	● FZ/WZ	2 608 640 784	C1a	1	1	239950		
160	16	-	- 2.4/1.6	18	●● FZ/WZ	2 608 640 785	C1a	1	1	239967		
160	20	-	- 2.4/1.6	12	● FZ/WZ	2 608 640 786	C1a	1	1	239974		
160	20	-	- 2.4/1.6	18	●● FZ/WZ	2 608 640 787	C1a	1	1	239981		
165	20	-	16 1.7/1.2	12	● FZ/WZ	2 608 642 600	C1a	1	1	660259		
165	20	-	16 1.7/1.2	24	●● FZ/WZ	2 608 642 601	C1a	1	1	660266		
165	30	-	- 2.4/1.6	18	●● FZ/WZ	2 608 640 789	C1a	1	1	240000		
184	16	-	- 2.4/1.6	24	●● FZ/WZ	2 608 640 795	C1a	1	1	240062		
190	20	-	16 2.6/1.6	24	●● FZ/WZ	2 608 640 799	C1a	1	1	240109		
190	30	-	- 2.6/1.8	12	● FZ/WZ	2 608 640 800	C1a	1	1	240116		
190	30	-	- 2.6/1.8	24	●● FZ/WZ	2 608 640 801	C1a	1	1	240123		
210	30	-	- 2.6/1.8	30	●● FZ/WZ	2 608 640 803	C1a	1	1	240147		
230	30	-	- 2.6/1.8	18	● FZ/WZ	2 608 640 804	C1a	1	1	240154		
230	30	-	- 2.6/1.8	30	●● FZ/WZ	2 608 640 805	C1a	1	1	240161		
235	30	-	25 2.6/1.8	30	●● FZ/WZ	2 608 640 807	C1a	1	1	240185		

Standard



Speedline Wood for table saws

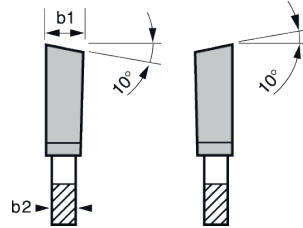
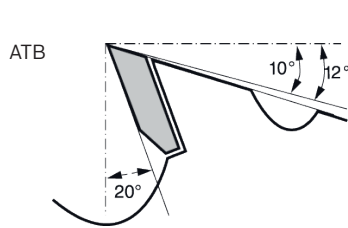
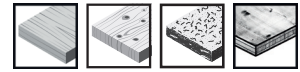

b1: width of cut
b2: base blade thickness

Standard
◆◆◆

Product properties							Ordering information					
Outer diameter mm	Bore size mm	Width of cut (b1) mm / Base blade thickness (b2) mm	Number of teeth	Cutting result	Tooth shape	Pin hole/Pitch circle diameter	Part number	Packaging type	Pack quantity	Minimum order quantity	Barcode 3165140...	
250	30	3.2/2.2	24	●●	ATB	7/42	2 608 640 680	C1a	1	1	194655	
300	30	3.2/2.2	28	●●	ATB	7/42 10/60	2 608 640 681	C1a	1	1	194662	
315	30	3.2/2.2	28	●●	ATB	7/42	2 608 640 682	C1a	1	1	194679	
350	30	3.5/2.5	32	●●	ATB	10/60	2 608 640 683	C1a	1	1	194686	
400	30	3.5/2.5	36	●●	ATB	10/60	2 608 640 684	C1a	1	1	194693	

Construct Wood for hand-held circular saws



- ▶ The special tooth design and the wide support in the tooth spine ensure high resistance and cut construction site timber with foreign bodies such as nails and concrete residues.

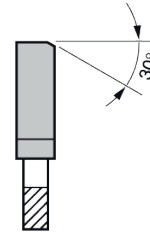
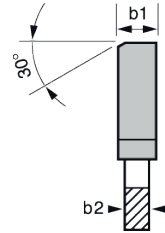
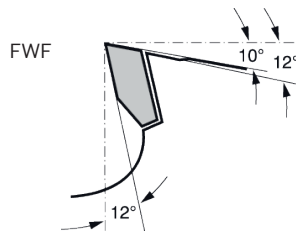
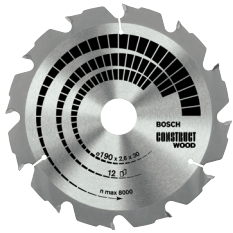
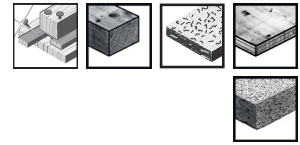

b1: width of cut
b2: base blade thickness

Product properties							Ordering information					
Outer diameter mm	Bore size mm	Bore with reduction ring mm	Width of cut (b1) mm / Base blade thickness (b2) mm	Number of teeth	Cutting result	Tooth shape	Part number	Packaging type	Pack quantity	Minimum order quantity	Barcode 3165140...	
150	20	16	2.4/1.4	12	●	FWF	2 608 641 199	C1a	1	1	373814	
160	20	16	2.6/1.6	12	●	FWF	2 608 640 630	C1a	1	1	194235	
180	30	20	2.6/1.6	12	●	FWF	2 608 640 632	C1a	1	1	194259	
184	16	-	2.6/1.6	12	●	FWF	2 608 641 200	C1a	1	1	373821	
190	20	16	2.6/1.6	12	●	FWF	2 608 641 201	C1a	1	1	373838	
190	30	-	2.6/1.6	12	●	FWF	2 608 640 633	C1a	1	1	194266	
210	30	-	2.8/1.8	14	●	FWF	2 608 640 634	C1a	1	1	194273	
230	30	-	2.8/1.8	16	●	FWF	2 608 640 635	C1a	1	1	194280	
235	30	25	2.8/1.8	16	●	FWF	2 608 640 636	C1a	1	1	194297	

Standard



Construct Wood for table saws (standard)

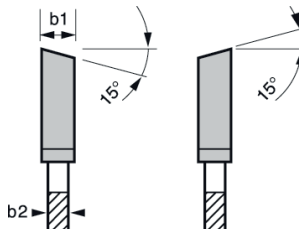
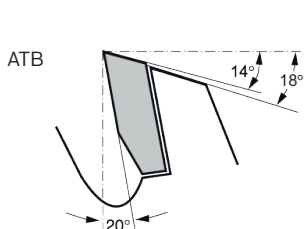
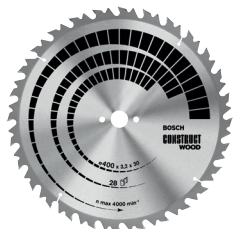
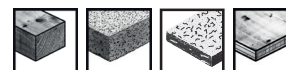

b1: width of cut
b2: base blade thickness

Outer diameter mm	Bore size mm	Width of cut (b1) mm / Base blade thickness (b2) mm	Number of teeth	Cutting result	Tooth shape	Pin hole/pitch circle diameter	Part number	Packaging type	Pack quantity	Minimum order quantity	Barcode 3165140...
Product properties						Ordering information					
300	30	2.8/1.8	20	●	ATB	7/42 10/60	2 608 640 700	C1a	1	1	194792
315	30	3.2/2.2	20	●	ATB	7/42	2 608 640 701	C1a	1	1	194808
350	30	3.2/2.2	24	●	ATB	10/60	2 608 640 702	C1a	1	1	194815
400	30	3.2/2.2	28	●	ATB	10/60	2 608 640 703	C1a	1	1	194822
450	30	3.8/2.8	32	●	ATB	10/60	2 608 640 704	C1a	1	1	194839
500	30	3.8/2.8	36	●	ATB	-	2 608 640 705	C0a	1	1	194846
600	30	4.0/3.0	40	●	ATB	-	2 608 640 761	C0a	1	1	236843
700	30	4.2/3.2	46	●	ATB	-	2 608 640 762	C0a	1	1	236850

Construct Wood for table saws (nail-proof)

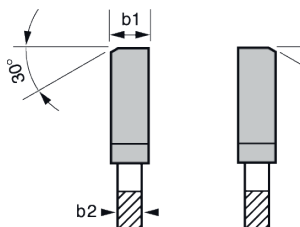
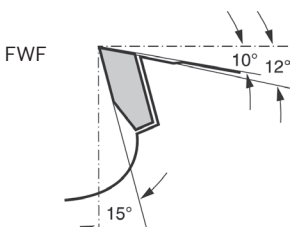
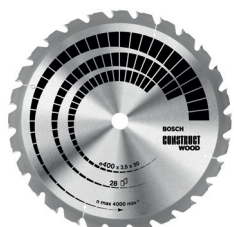
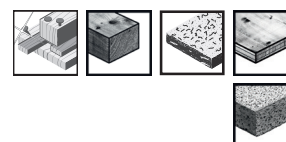

b1: width of cut
b2: base blade thickness

250	30	3.2/2.2	20	●	FWF	7/42	2 608 641 774	C1a	1	1	455626
300	30	3.2/2.2	20	●	FWF	7/42 10/60	2 608 640 690	C1a	1	1	194730
315	30	3.2/2.2	20	●	FWF	7/42	2 608 640 691	C1a	1	1	194747
350	30	3.5/2.5	24	●	FWF	10/60	2 608 640 692	C1a	1	1	194754
400	30	3.5/2.5	28	●	FWF	10/60	2 608 640 693	C1a	1	1	194761
450	30	3.8/2.5	32	●	FWF	10/60	2 608 640 694	C1a	1	1	194778
500	30	3.8/2.5	36	●	FWF	10/60	2 608 640 695	C0a	1	1	195294

Multi Material for hand-held circular saws

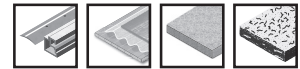

- ▶ The perfect blade for powerful cuts with clean cut edges in all different kinds of materials.
- ▶ Using the universal cutting oil 2 607 001 409 increases the lifetime several times over when cutting in metal, e.g. aluminium.

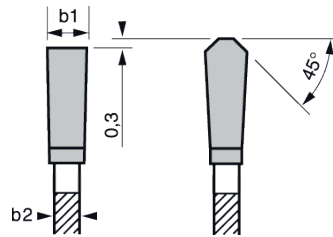
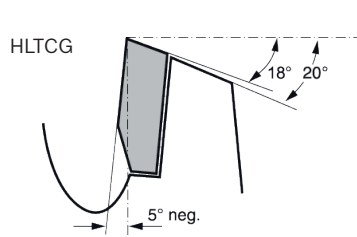

b1: width of cut
b2: base blade thickness

Outer diameter mm		Bore size mm		Bore with reduction ring mm		Width of cut (b1) mm / Base blade thickness (b2) mm		Number of teeth		Cutting result		Tooth shape		Part number		Packaging type		Pack quantity		Minimum order quantity		Barcode 3165140...	
Product properties												Ordering information											
130	20	16	2.0/1.4	42	●●●●	HLTCG	2 608 641 195	C1a	1	1	373777												
150	20	16	2.0/1.4	42	●●●●	HLTCG	2 608 640 501	C1a	1	1	192910												
160	20	16	2.4/1.8	42	●●●●	HLTCG	2 608 640 503	C1a	1	1	192934												
165	30	-	2.4/1.8	42	●●●●	HLTCG	2 608 640 519	C1a	1	1	193092												
180	30	20	2.4/1.8	48	●●●●	HLTCG	2 608 640 507	C1a	1	1	192972												
184	16	-	2.4/1.8	48	●●●●	HLTCG	2 608 640 815	C1a	1	1	263405												
184	30	-	2.4/1.8	48	●●●●	HLTCG	2 608 640 506	C1a	1	1	192965												
190	20	16	2.4/1.8	54	●●●●	HLTCG	2 608 640 508	C1a	1	1	192989												
190	30	-	2.4/1.8	54	●●●●	HLTCG	2 608 640 509	C1a	1	1	192996												
200	30	-	2.4/1.8	54	●●●●	HLTCG	2 608 640 510	C1a	1	1	193009												
210	30	-	2.4/1.8	54	●●●●	HLTCG	2 608 640 511	C1a	1	1	193016												
230	30	-	2.4/1.8	64	●●●●	HLTCG	2 608 640 513	C1a	1	1	193030												
235	30	25	2.4/1.8	64	●●●●	HLTCG	2 608 640 514	C1a	1	1	193047												



Multi Material for mitre saws and table saws

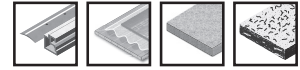

- ▶ Using the universal cutting oil 2 607 001 409 increases the lifetime several times over when cutting in metal, e.g. aluminium.

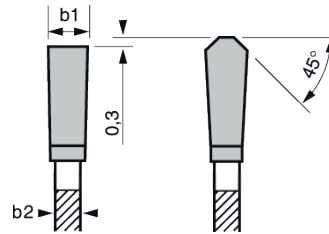
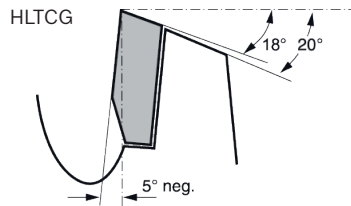

b1: width of cut
b2: base blade thickness

Standard
◆◆◆

Outer diameter mm	Bore size mm	Width of cut (b1) mm / Base blade thickness (b2) mm	Number of teeth	Cutting result	Tooth shape	Pin hole/pitch circle diameter	Part number	Packaging type	Pack quantity	Minimum order quantity	Barcode 3165140...
Product properties						Ordering information					
210	30	2.5/1.8	80	●●●	HLTCG	-	2 608 640 445	C1a	1	1	317436
216	30	2.5/1.8	60	●●	HLTCG	-	2 608 640 446	C1a	1	1	317443
216	30	2.5/1.8	80	●●●	HLTCG	-	2 608 640 447	C1a	1	1	317450
250	30	3.2/2.5	80	●●●	HLTCG	7/42	2 608 640 516	C1a	1	1	193061
254	30	3.2/2.5	60	●●	HLTCG	-	2 608 640 449	C1a	1	1	317474
254	30	3.2/2.5	80	●●●	HLTCG	-	2 608 640 450	C1a	1	1	317481
254	30	3.2/2.5	96	●●●●	HLTCG	-	2 608 640 451	C1a	1	1	317498
260	30	3.2/2.5	80	●●●	HLTCG	-	2 608 641 204	C1a	1	1	373869
300	30	3.2/2.5	96	●●●●	HLTCG	7/42 10/60	2 608 640 518	C1a	1	1	193085
305	30	3.2/2.5	80	●●●	HLTCG	-	2 608 640 452	C1a	1	1	317504
305	30	3.2/2.5	96	●●●●	HLTCG	-	2 608 640 453	C1a	1	1	317511
350	30	3.2/2.5	96	●●●●	HLTCG	-	2 608 640 770	C1a	1	1	236935

Always the right circular saw blade

The machine overview

Hand-held circular saws

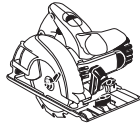

	Outer diameter in mm	Bore in mm
AEG		
MBS 30 Turbo SET	127	20
HK 40	140	20
HK 46N	150	20
HK 55, K 55, K 55S, K 55SE, TS 55E	160	20
BKS 18	165	16
KS 55C	165	20
KS 66C	184	30
HK 66, HK 66E, KS 66S	190	30
HK 75A	210	30
Atlas Copco		
LCS 10	50	10
LCS 38 S150	100	12
TKS 42	130	20
K 55, K 55S	160	20
K 66S, K 66SE, SCS 66Q	190	30
HKS 75	210	30
HKS 85	230	30
Black & Decker		
BD 227, BD 840, BD 846, CD 600, DN 227, KS 40, KS 227, KS 840, KS 846, P 3601	140	12.7
BD 855, KS 855, SR 325E, U 336, U 975, U 976	160	16
CD 601, CS 1030L	170	16
HD 1200	180	20
BD 229, BD 865, BD 865E, DN 59, DN 229, DN 820, GD 60, HD 100, HD 1000, HD 2062, KS 865, KS 865E, P 3703, P 3705, PL 40, PS 3703, PS 3705, SR 300, SR 362E	184	16
KS 64, KS 65K, KS 1300, KS 1400L, KS 1500LK	190	16
BD 365, PL 41	190	30
HD 2075S, KS 805, KS 810, P 3802	210	30

	Outer diameter in mm	Bore in mm
P 3902, HD 2066S	230	30
Bosch		
GKS 10,8 V-Li	85	15
PKS 38, PKS 40, PKS 14,4 V	130	16
PKS 46	150	16
GKS 54, GKS 54 CE, PKS 54, PKS 54 CE	160	16
GKS 55, GKS 55 CE, GKS 160, GKS 24 V, GKS 55 GCE, PKS 55 A	160	20
GKT 55 GCE, GKS 18 V, GKS 18 V-LI, GKS 36 V-LI	165	20
GKS 65, GKS 68 BC, GKS 65 CE, PKS 66, GKS 66, GKS 66 CE, GKS 65 GCE, GKS 190, GKS 65 G, PKS 66 AF, PKS 66 A	190	30
GKS 75 S	210	30
GKS 85 S, GKS 85 G, GKS 85	235	30
DeWalt		
DW 935K, DW 936K	136	10
DCS373B, DCS373M2	140	16
DW 351	150	20
DW 390KA, DW 007	165	10
DWE550, D23550, D23551, DC 390KB, DC 390N, DC 390KL, DC S391L2	165	20
DW 62, DW 62K, D23620, DWE560, DWE575SB	184	16
DC 300KL, DC 300KN	184	20
DW 65, DW 365, D23650K, D23651K, DWE575K, DWE576K	190	30
DW 712, DW 777, DW 771	216	30
D 23700	235	30
DW 86	240	30

	Outer diameter in mm	Bore in mm
DW 717 XPS, DW S778	250	30
Einhell		
BT-CS 860L	85	10
TE-XC 110	110	22
BT-CS 1200/1	160	16
RT-CS 165	165	16
BT-CS 1400/1	190	20
RT-CS 190/1	190	30
Elu		
MH 151	150	20
GKS 24V	160	20
GKS 36V-LI	165	20
MH 155	170	30
MH 65	180	30
MH 165, MH 265	190	30
MH 85, MH 286	240	30
Evolution		
EVO 180, E180 Xtreme	184	20
FURY 185, RAGE, RAGE-B	185	20
RAGE230	230	25.4
EVO 230	235	25.4
FURY2 355, EVO355	355	25.4
Ferm		
CSM 1033	185	20
Festo/Festool		
AP 55, AP 55E, ATF 55, ATF 55E, ATF 55EB, TS 55, TS 55 R, TS 55 RQ-Plus	160	20
AT 55E, AXT 50LA	170	30
AU 55S, AU 60P	180	30
AP 65, AP 65E, AP 65EB, AT 65, AT 65EB	190	30
AU 65, AD 65	200	30
TS 75, TS 75 EBQ	210	30
CS 70, CS 70EB	225	30
AP 85, AP 85E, AP 85 EB	240	30
HK 132E	350	30

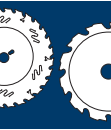

	Outer diameter in mm	Bore in mm		Outer diameter in mm	Bore in mm		Outer diameter in mm	Bore in mm
Flex			SP6000X1, SP6000K1, 5603RK	165	20	KS 1266S, KS 1468S	190	20
CSM 4060	185	20	MKS 65, FS 130K, FS 165K	190	30	KS 66, KS 68, KS 68 Plus, KSE 66 Plus	190	30
Güde			B 65	200	30	KSE 1678S	210	30
HKS 1200	185	20	MKS 75	210	30	Metallkraft		
Hilti			MKS 85	225	30	HKS 230	230	25.4
WSC 55	160	20	KSP 85, KSP 85F, KSP 85FC	230	30	Milwaukee		
SCW 22-A, SCM 22-A	165	20	KSS 800 Ec/370, K 85, K 85 Ec	237	30	HD 18 MS	135	20
WSC 70-A, SCW 70	190	30	MKS 130 Ec	330	30	HD 28 CS, HD 18 CS	165	16
WSC 85	230	30	MKS 145 Ec	370	30	CS 55	165	30
Hitachi			MKS 165 Ec	410	30	CS 60	184	30
C 6BU, C 6BU 2, C 6U, C 6U2, C 18DSL (4.0L), C 18DSL (Slide)	165	30	MKS 185 Ec	450	30	SCS 65 Q, CS 75	190	30
C 7BU, C 7U	184	30	Makita			MCS 66, MCS 65	203	16
C 7BU2, C 7MFA, C 7U2	190	30	HS 300DWJ, HS 300DZ	85	15	Rexon		
C 8U	210	30	BSS 501RFJ, BCS 550RFJ, BSS 500RFJ	136	20	MC1850R	185	20
C 9BU2, C 9U, C 9U2	235	30	BSS 610 RFJ, DSS 610RMJ, DSS 610ZJ, DHS 630RFJ, DHS 630ZJ, SP 6000J1, HS 6101, HS 6101X1, 5603R, 5603RK, 5604R, SP6000K1, SP6000X1, 5017RKB, HS6101, 5604R	165	20	Ryobi		
C 13U	335	30	BLS 713RFE	190	20	RWSL1801M	150	10
Holz-Her			HS 7101, HS 7101J1, 5017R, 5703R, 5704R, 5704RK, 5705R, 5705RX, HS7101, 5017RKB	190	30	EWS1150RS2, EWS1150RS	170	20
2110, 2111, 2171	130	20	5900B, 5900BR, SR 2300	235	25	RWS1600-K, EW- S1366HG	190	16
2260, 2270	140	20	5903R, 5903RK, N5900B	235	30	Scheppach		
2103, 2104, 2105, 2106, AP 55EB, ATF 55EB	160	20	5103R	270	30	cs 45	145	20
2115, 2266, 2271, 2281	170	30	5143R	355	30	cs 55	160	20
2112, HKU 55	180	30	Metabo			Skil		
2117, 2119, AP 65EB, AT 65EB	190	30	KS 0852S	150	20	5140, 5240, 5740, 5144, 5740 CA	130	16
2113	200	30	KS 54, KS 54 SP, KSE 55 Plus, KSE 55 Vario Plus, KS 55 FS	160	20	5940 MA, 5840, 5840 AB	140	20
2267	210	30	KSA 18 LTX (6.02268.86), KSA 18 LTX (6.02268.87), KSA 18 LTX (6.02268.89)	165	16	5750, 5855	160	16
2118, 2120, 2294	230	30	KS 1155S, KS 1157S, KSTE 1357S	165	20	5155, 5255 AA	170	16
2268	240	30				5165 AA, 5165 GR, 5265 AA, 5265 AD, 5065 MA, 5003, 5164, 5064	184	16
Jepson						5066, 5166, 5266, 5366, 5466, 5566, 5766, 5866	190	16
8219 Hand Dry Cutter	192	20				5885, 5885 MA	235	30
8230 AIR Hand Dry Cutter, 8230 N	230	25.4				Stayer		
8230 Hand Dry Cutter	235	25.4				85	85	15
Keyang						DS 125	125	22.2
CS 1800L	165	20				CH 185 B	185	20
CS 7S	185	20				CP 190 B	190	25.4
Kress						CM 230 K	230	25.4
CHKS 6055	160	20				CP 236	235	25.4
CHKS 6066, 1400 HKS, 1500 KS	190	20				Wegoma		
Mafell						SR 74K	153	20
KSP40, KSP 55, KSP 55/36V, KSP 55F, KST 55, MKS 55, MKS 55F, MS 55, MS 55 / 36V, MS 55cc, KSS 300, KSS 400, KSS 400 / 36 V, PSS 3100 SE	160	20				TS 160	160	20
						SR 90J	200	30
						TS 230	230	30

Mitre saws



	Outer diameter in mm	Bore in mm
AEG		
PS 305 DG	305	30
Atika		
KGS 210, KGS 210 N, KGSZ 210	210	30
KGSZ 250 N	250	30
KGSZ 255	255	25.4
KGSZ 305	305	25.4
Atlas Copco		
MS 3 C	250	30
MS 3 C	254	30
Black & Decker		
SR 700, BD 800, DN 800, DN 810, SEC 818	210	30
Bosch		
PCN 7, PCN 7S	190	30
PCM 8ST, PCM 8S	210	30
GCM 8 SJL, GCM 8S	216	30
GTS 10, PCM 10	250	30
GCM 10, GCM 10 SD, PCM 10, GCM 10 S, GCM 10 J, GKG 24 V, PCM 10T	254	30
GCD 12 JL	305	25.4
GTM 12, GTM 12 JL, GCM 12 JL, GCM 12, GCM 12 SD, GCM 12 GDL	305	30
DeWalt		
DW 700, DW 701, DW 707, DW777	216	30
DW 702, DW 703, DW 710, DW 713 XPS, DW 713, DW 742, DW 744, DW 743, DW 743N, DW 704, D27107, D27107V, DW716	250	30
DW 709, DW 711	260	30
DW 705, DW 706, DW 708, DW 716 EXPS, D27105, DW 718, DW S780, D 27111, D 27112	305	30
DW 872, DW 872 XE	355	25.4

	Outer diameter in mm	Bore in mm
Einhell		
KGS 210, BT-MS 210, BT-SM 2131 Dual, BT-MS 2112, RT-SM 305 L	210	30
KGTN 245,	250	20
RT-SM 430 U, BT-MS 250L, KGTN 250, RT-XM 305 U, BT-SM 2534 Dual	250	30
KGTN 245, KGTN 250, KGS 250	254	30
Elu		
PS 174, PS 274, PS 274E, ETS 41	216	30
TGS 170, TGS 171, TGS 172, TGS 173, TGS 271, TGS 273	250	30
PS 374, EMS 705	305	30
Evolution		
FURY3B 210, FURY3 210, RAGE3-B 210, RAGE3-S 210, RAGE3-S300 210	210	25.4
FURY3XL 255, RAGE3 255, RAGE3-DB 255	255	25.4
355 Raptor	355	25.4
Ferm		
MSM 1031, MSM 1033, MSM 1034	210	30
MSM 1032	255	30
Festo/Festool		
SYM 70 E, SYMMETRIC SYM 70	216	30
AD 100, AD 85, AE 85, AE 88	250	30
KS 120, KAPEX KS 120, KS 120 EB, KAPEX KS 88, KS 88 E	260	30
Flex		
TCS 3602	355	25.4

	Outer diameter in mm	Bore in mm
Güde		
GKS 1100 P, KT 210, GKS 210 PLUS, GRK 210/300	210	30
GFO 1401	216	30
GKS 250 T, GRK 250/300, GRK 250/500, GRK 250/300LP	250	20
GFO 1801	254	20
GMK 350 T	355	25.4
Hitachi		
C 8 U, C 8 FA, PSM 8 A, PSU 8	210	30
C 8 FC, C 8 FS, C 8FSHE	216	30
C 10 FCA, C 10FCB	250	30
C 10FCH2, C 10FCE2, C 10 FSH	255	30
C 12LSH, C 12RSH, C 12LCH, C 12YA, C 12YB	305	30
CD12F	305	25.4
CD14F	355	25.4
Holz-Her		
2279, 2264, 2555, HK 201	210	30
2161, 214101 Sym-strict	216	30
Huvema		
HU 355, AM 355 Drycutter 2	355	25.4
Jepson		
9211D Dry Mitre Cutter	254	25.4
9410 ND	255	25.4
9430 Premium Dry Cutter	305	25.4
9435 Premium Super Dry Cutter, 9515 Cut-Off Saw	355	25.4
JET		
JMS -8	210	16

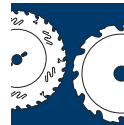

	Outer diameter in mm	Bore in mm
JMS-10, JMS-10S, JSMS-10L, JM- STT-10	254	30
Keyang		
DC-355	355	25.4
Kress		
GST 90	250	30
GST 90	254	30
Lutz		
TKS HVK, TKS	315	30
Makita		
LS 0714FB	190	20
LS 1030, MILS 100, MLS 100	255	30
LS 1040, LF 1000, LH 1040F, LS 1016LB, LS 1040F, LS 1013, LS 1013LB, LS 1018L	260	30
LH 1200FL, LS 1216LB, LS 1214F, LS 1214L, LS121	305	30
LC 1230	305	25.4
Metabo, Elektra Beckum		
GKSE 16705, Signal, KGSE 1670 S, KGS 255, KS 250, KS 304, KGT 250, P 200, PK 200, UK 220 E, UK 220 W	210	30
KS 215 M Lasercut, KS 216 M Lasercut, KGS 216 M, KS 216 Plus, KGS 216 Plus	216	30
KGS 250, KGS 331, KGS 300, KGT 500, KGT 501, KGT 550, KGS 330, Hobymaster, KGS 301, KGS 303	250	30
KS 254 Plus, KGS 254 I Plus, KGS 254 M, KGS 254 Plus	254	30
KS 304, KS 305 Plus	305	30
KSG 315 Plus, KGS 315 Plus	315	30

	Outer diameter in mm	Bore in mm
Metallkraft		
MTS 500	305	30
MTS 355, MTS 356	355	25.4
Milwaukee		
MS 216 SB	216	30
6494-50, 6496-50	250	30
MS 305 DB	305	30
6190-20	355	25.4
Rexon		
GC 1950R	195	25.4
MS 8 RAL, SM 2151 AL, SM 2150 AE, SM 2153AE, M 2150 AE	216	30
SM 2500 VA, M 2500 AE, SM 2502AE	250	30
M 2500 AL, M 2503 AL, SM 2500 AL	254	30
SM 2502 A, M 2503 R, M 2507 R	254	25.4
SM 2501 AE, TMS 10 A	255	30
MS 2500 R	255	25.4
SCM 12 A, MS 12 RA, SM 3051 AL, M 3051 AL	305	30
DC 356A, DC 3550 A	355	25.4
Ridgid		
590	305	25.4
590L	355	25.4
Ryobi		
EMS190DCL	190	30
EMS216L	216	30
EMS254L, ETMS1825HG, EMS 2026 SCC, EMS 2025 SCL	254	30
Scheppach		
Capas 1, Capas 2	216	30
KG 260 E, KSE 250, TKG 260 i, TKG 260 E, TKG 280 E	250	30
kg 251, kgz 251, KG 260E, TKG 260i, TKG 260E, TKG 280E	254	30
Capas 5.0	255	30

	Outer diameter in mm	Bore in mm
TKG 305i, TKH, TKU, TS 400, TS 4010, Mitas 7	300	30
Capas 3, Capas 7	305	30
Skil		
1131AA	210	30
3855 MA	216	30
Stayer		
SC206BW, SC211W, SC 210 W, SC 211 BW	210	30
SLL 250, SCE 1600, SC 270, SC 271, SLL 250 E, SLL 251, SL 251 E, SC 250 W, SC 2500 W	250	30
SC 291 W, SCR 255 W, SCE 1650 W MC, SLL 265 W, SC 265 W, SC 251 W, SLL 250, SCE 1600, SC241W, SC251W, SC 270, SC 271, SLL 250 E, SLL 251, SL 251 E	254	30
SC 3000 W, SLL 3000 W, SLL 391 W, SC 391 W, SC 311 W, SC 300 W	305	30
SCR 315 W	315	30
SCG 350 W AL, SCG 350 W	350	30
TD 355 W	355	25.4
Wegoma		
TM 43 D, KGS48, KGS48T, TS 48 D	250	30
KGS33, KGS33T, KGS72, KGS72T	300	30

Table saws

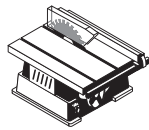

	Outer diameter in mm	Bore in mm
AEG		
TS 250K	250	30
Atika		
T 205	205	16
Toptronic, T 250 ECO, TK 250, PTK 250 S, T 250 N	250	30
T 250	254	30
HT 315, BTA 90	315	30
ABH400, ABK 400	400	30
ABH450, ABK 450, ATU	450	30
ABH500, ABK 500	500	30
Avola		
LH 315, TZV 315	315	30
TZH 350	350	30
ZB/W 400, ZBV/W 400, ZB400, ZBV400	400	30
IC 450, ZB450, ZBV450	450	30
ZB500, ZBV500	500	30
Black & Decker		
T250 Eco	250	30
Bosch		
PPS 7S	190	30
GTS 10, PTS 10T	250	30
GTS 10 J, GTS 10 XC, PTS 10, PTS 10T, GTS 10	254	30
GTM 12	305	30
DeWalt		
DW744, DW746, DW745, DW745RS, DW744XPRS, DW744XP, DW743N	250	30
D27107, D27107V	305	30
Einhell		
BT-TS 800, BT-TS 1500 U, TKS 1500 ECO	200	16
RT-TS 920	205	16
RT-TS 1221	210	30
RT-TS 1725 U, RT-TS 1825U	250	30
RT-TS 2031 U, RT-TS 2331 UD, BKS 315, RT-CC 315 U	315	30
Evolution		
FURY6 210	210	25.4
FURY5 255, RAGE5 255, RAGE6 255	255	25.4

	Outer diameter in mm	Bore in mm
Ferm		
TSM 1032	200	16
TSM 1030, FZT 250	250	30
TSM 1031	254	30
Festo/Festool		
PRECISIO CS 50, CS 50 EB	190	Star- shaped
PRECISIO CS 70, CS 70 EB	225	30
AXP 130, AXP 132 E, BD 125	350	30
BD 145, BD 145/1	400	30
BD 170	450	30
Güde		
GTK 800	200	16
GUKS 2100	210	30
TK 2400 ECO, TK 2500	250	30
TK 2400 P	254	30
GTKS 1800 Pro	255	30
GTKS 315/230V, GTKS 315/400V/ 2,2KW, GTKS 2200 Pro 230V	315	30
Hanning		
HTK 315/3 SV, HTK 315/1.6, HTK 2.1, HTK 315/3.0, HTK 4.0	315	30
Hitachi		
PSU 13	315	30
Holz-Her		
PKS 1210, PKS 1211, PKS 1212, PKS 1213, PKS 1215, PKS 1220, PKS 275, HKD 85, HKD 275	300	30
150, 176, 276, HKS 130, HKS 150, HKS 276, HKS 176	350	30
277, BZK, HKS 155	400	30
Huvema		
315 ST	315	30
JET		
JTS-8	205	16
JTS-250CS, JTS-600X	250	30
JTS-10	254	30
JTS-315S, JTSS- 1500, JTS-315SP	315	30
Lutz		
TKS HVH, TKS V, Eurocut	315	30
BK 450	450	30

	Outer diameter in mm	Bore in mm
Mafell		
ERIKA 60 E	190	30
ERIKA 70 Ec	225	30
ERIKA 85 Ec	250	30
Biber, Biberix, FS 85, MKS 105, MKS 105E, Monika, TFK 85, TFK 8	315	30
AZB, BK 3, BSK 4, BSK 5, BSK 6, TD 3, TDH 4, TDH 425, TK 150, VKS 130, VKS 160, FKB 150, FS 1305, FS 130 (S)	400	30
TDH 450, TDH 5, FSG 200, FSG 240 K	450	30
170, BKV 5, TDH 5	500	30
Makita		
MILT100X, MLT 100X, 2704	260	30
Metabo, Elektra Beckum		
UK 290, UK 333	220	30
TK 1685 Magnum, TK 1685, TKU 1633, TKU 1693, TS 250, KGT 501	250	30
TS 254	254	30
TK 1685, TK 1688 (D)(Magnum)	300	30
KGT 300, TK 1685, TK 1685 Magnum, TK 1688 Magnum, TKHS 315, TKHS 315 C - 2,0 WNB, TKHS 315 C - 2,8 DNB, TKHS 315 M - 3,1 WNB, TKHS 315 M - 4,2 DNB	315	30
BKS 400, BKS 400 Plus-3,1 WNB, BKS 400 Plus-4,2 DNB	400	30
BKS 450, BKH 450, BKH 450 Plus- 5,5DNB, BKS 450 Plus-5,5 DNB	450	30
Rexon		
BT 2160 A	216	30
BT 2500 AE, BT 2504AE, BT2502AE	250	30
JT 2502 R, BT 2504 RC	254	15.875
PT 2502 R2	254	25.4
JT 2501 A	255	30
TS 3150 A	315	30

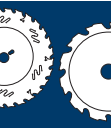

Scoring blades for panel sizing saws

	Outer diameter in mm	Bore in mm
Ryobi		
ETS1525SCHG, ETS1526HG	254	30
Scheppach		
Precisa 2.0	200	30
Precisa 4.0, Forsa 3.0	270	30
Precisa 3.0	280	30
Forsa 4.0, TKU, Forsa 9.0, Forsa 8.0, Forsa 6.0, Forsa 4.1, Tisa 3.0, Tisa 5.0, ts 310, TS 315GT, TS 4010 ci	315	30
Precisa 6.0	316	30
BSH 500, BS 400	400	30
BS 500, Structo 7.0, Structo 5.0	500	30
Ulmia		
1610, 1622, 1625, 1710 S, 1710 R, KS 1	250	30
1711, 1725	300	30
1712, 1712 RT, 1712R	350	30
Variolux		
OKS 315	315	30
Wegoma		
TM 43 D, TS 48 D	250	30
TM 33 H, TS 33 H, TM 72 C, TS 72 C	300	30
S 5 D	350	30
TKS 400 M, TKS 400 A	400	30

	Outer diameter in mm	Bore in mm
Altendorf		
WA 8	120	22
Griggio		
SC 32/350	100	20
SC 32/300, SC 1400	120	20
UNICA 500	125	20
Paoloni		
S100, S150, S200, S260, S300, P350NX, P350SX, P350AX	120	20
P315, P45, P3200NX, P3200SX, P3200AX, P450NX, P450SX, P450AX	125	20
Robland		
NLX-310, E-300, NZ-3200, NLX-TZ	125	20
SCM		
SI300 S NOVA, SI300 NOVA, SI400 NOVA, SI400 E NOVA, SI400 EP NOVA	120	20

Panel sizing saws

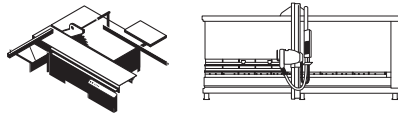

	Outer diameter in mm	Bore in mm
Altendorf		
WA 8, WA 80, F45/F45 ELMO	250	30
WA 8, WA 80, F45/F45 ELMO	300	30
WA 8, WA 80, F45/F45 ELMO, WA 6	315	30
WA 8, WA 80, F45/F45 ELMO, WA 6	350	30
WA 8, WA 80, F45/ F45 ELMO	400	30
F45/F45 ELMO	450	30
F45/F45 ELMO	500	30
Einhell		
RT-CC 315	315	30
Felder		
KF 700 Professional	250	30
Kappa 30, Kappa 40, Kappa 40 X-Motion	400	30
Griggio		
CA 400 DIGIT, CA 400 E, CA 400, CA40, UNICA 500 E	250	30
SC 32/300, SC 1400, CA 400 DIGIT, CA 400 E, CA 400, CA40	300	30
Unica 350	315	30
UNICA 500 E, SC 32/350, CA 400 DIGIT, CA 400 E, CA 400, CA40, UNICA 500 E, Unica 350	350	30
CA 400 DIGIT, CA 400 E, CA 400, CA40, UNICA 500 E	400	30
CA 400 DIGIT, CA 400 E, CA 400, CA40, UNICA 500 E	450	30
UNICA 500 E	500	30

	Outer diameter in mm	Bore in mm
Guilliet/Chambon		
Verti 1850, Verti 2150	250	30
CoupeS, CoupeC	400	30
CoupeMAX, Coupe-MASSIF	500	30
JET		
JTSS-700, JTS-700L	250	30
JTS 300, JTSS 300	300	30
JTSS-1500, JTSS-1700, JTSS-2500, JTSS-3200	315	30
Lutz		
JUMBO plus	315	30
Martin		
T60 Basic	250-315	30
T60 Classic	250-400	30
T74 Automatic	250-500	30
T74 Classic, T70, T75 PreX	250-550	30
T60 PreXision, T65	300-315	30
Panhans		
690-B Easy4mat, 690-B Electronic III plus	450	30
PS32	350-400	30
Paoloni		
S100, S150, S200, S260, S300	300	30
P315	315	30
P350NX, P350SX, P350AX	350	30
P450NX, P350SX, P450AX, P3200NX, P3200SX, P3200AX	450	30

	Outer diameter in mm	Bore in mm
Robland		
NLX-310, NLX-TZ, EZ2500-EZ3200- EZ3800	300	30
NX-310, NX-Z, NX-TZ, E-300, EZ-2500	315	30
Z2500, Z-3200, NZ Axis Ergo	400	30
PS3200 X-3, NZ3200-NZ3800, Z3200-Z3800	450	30
SCM		
SI300 S NOVA, SI300 NOVA	315	30
SI400 NOVA, SI400 E NOVA, SI400 EP NOVA	400	30
Sicar		
TS 250	300	30
Striebig		
Compact	250	30
Standard, Evolution, Control	300	30
Ulmia		
KS 300	315	30

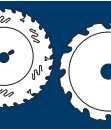

Recommendations

for achieving the optimum cut



Recommended maximum speed for the saw blade rotation

The maximum permitted RPM of a circular saw blade varies based on the diameter of the blade itself. The maximum RPM stated on the circular saw blade must not be exceeded under any circumstances. If you exceed this limit, the saw blade will lose its properties. This will affect the cutting quality and the lifetime of the blade itself, not to mention causing the risk of the serious injury to the user.

Recommended revolutions per minute (RPM) by blade diameter

Saw blade diameter	Maximum RPM
80 mm	23,800 RPM
100 mm	19,100 RPM
120 mm	15,900 RPM
125 mm	15,200 RPM
210 mm	9,000 RPM
216 mm	8,800 RPM
250 mm	7,600 RPM
254 mm	7,500 RPM
300 mm	6,300 RPM
303 mm	6,300 RPM
305 mm	6,200 RPM
315 mm	6,000 RPM
350 mm	5,400 RPM
400 mm	4,700 RPM
450 mm	4,200 RPM
500 mm	3,800 RPM

Recommended revolutions per minute by material

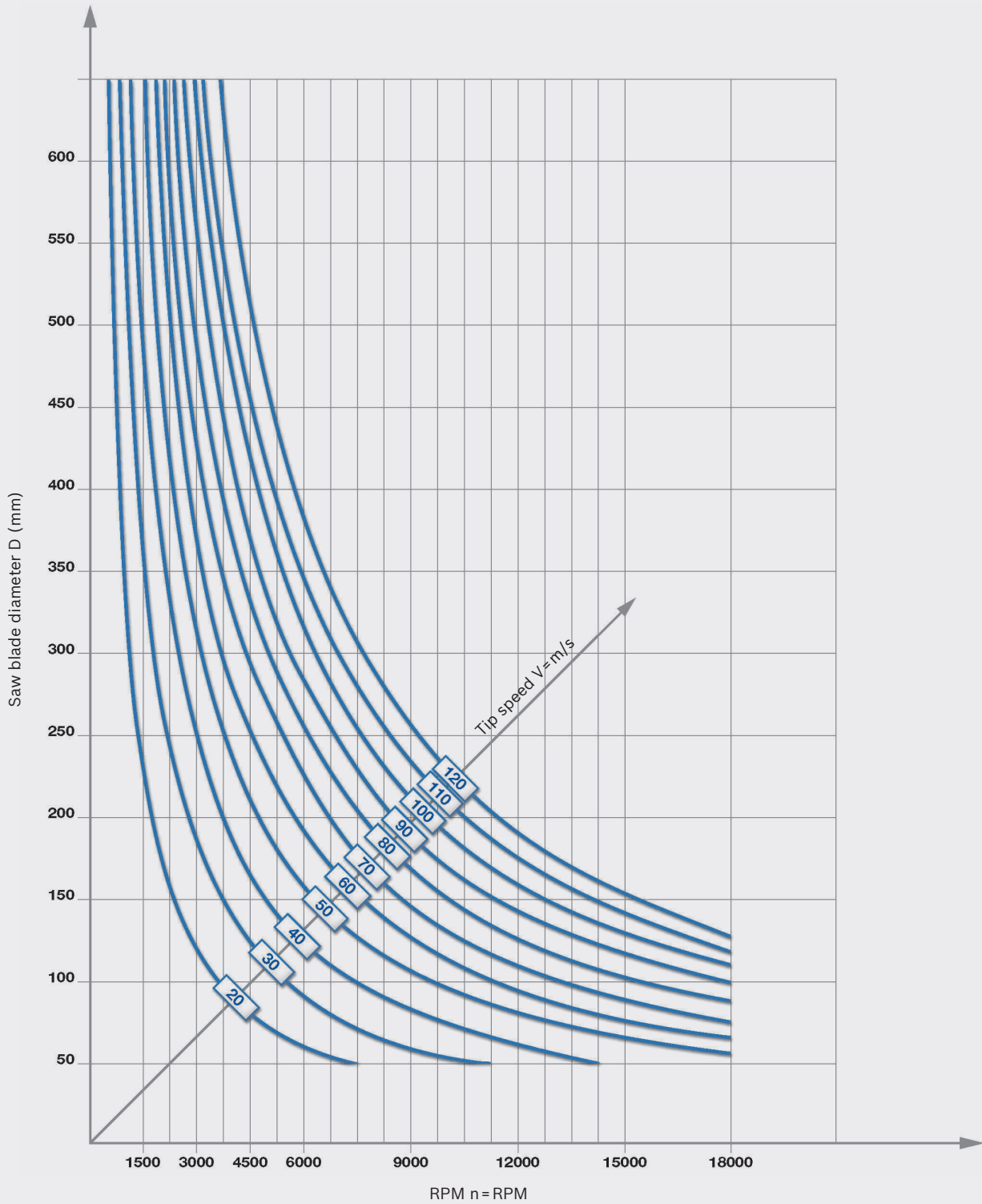

Optimal cutting speed by material

Softwood	50–90 m/s
Hardwood	50–80 m/s
Exotic wood	50–85 m/s
Chipboard wood	60–80 m/s
Joinery wood	60–80 m/s
MDF	30–60 m/s
Laminated and Bilaminated	40–60 m/s

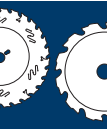

Technical table showing the correct tooth feed rate, material feed rate, number of teeth and RPM for the saw blade

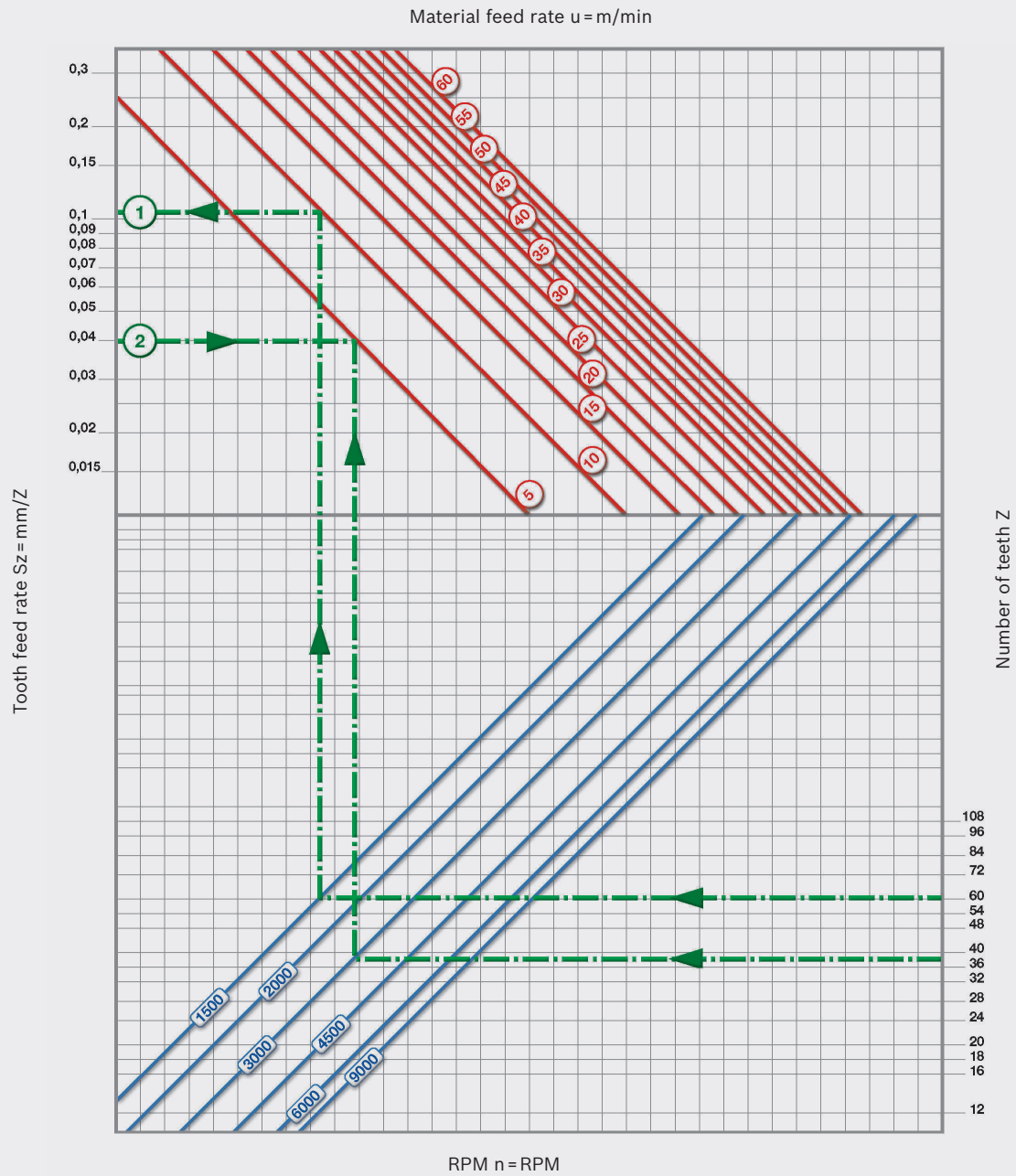

Recommended tooth feed rate (S_z = mm/tooth)	
Softwood with grain	0.20-0.30
Softwood across grain	0.10-0.20
Hardwood	0.06-0.15
Chipboard	0.10-25.0
Plywood	0.05-0.12
Laminated panel	0.05-0.10
Aluminium and plastic laminated chipboard	0.02-0.05

Example 1
 $n = 1,500$ RPM
 $u = 10$ m/min
 $Z = 60$
 $S_z = 0.11$ mm

Example 2
 $n = 3,000$ RPM
 $Z = 40$
 $S_z = 0.04$ mm
 $u = 5$ m/min

Accessories

for circular saws

Reduction rings for circular saw blades



Product properties			Ordering information				
Diameter mm	Bore mm	Thickness mm	Part number	Packaging type	Pack quantity	Minimum order quantity	Barcode 31 65140...

Reduction rings for circular saw blades
Base blade thickness of 1.0 mm up to max. 1.3 mm

20	12.75	0.8	2 600 100 185	P1b	1	1	433518
20	15.875	0.8	2 600 100 186	P1b	1	1	433525
20	16	0.8	2 600 100 187	P1b	1	1	433532

Reduction rings for circular saw blades
Base blade thickness of 1.25 mm up to max. 1.4 mm

20	16	1.0	2 600 100 188	P1b	1	1	433549
----	----	-----	----------------------	-----	---	---	--------

Reduction rings for circular saw blades
Base blade thickness of 1.4 mm up to max. 1.7 mm

16	12.75	1.2	2 600 100 192	P1b	1	1	433587
20	10	1.2	2 600 100 193	P1b	1	1	433594
20	12.75	1.2	2 600 100 194	P1b	1	1	433600
20	13	1.2	2 600 100 195	P1b	1	1	433617
20	16	1.2	2 600 100 197	P1b	1	1	433631
25	15.875	1.2	2 600 100 201	P1b	1	1	433679
25	16	1.2	2 600 100 202	P1b	1	1	433686
25	20	1.2	2 600 100 203	P1b	1	1	433693
25.4	20	1.2	2 600 100 207	P1b	1	1	433730
30	20	1.2	2 600 100 208	P1b	1	1	433747
30	24	1.2	2 600 100 209	P1b	1	1	433754
30	25	1.2	2 600 100 210	P1b	1	1	433761
30	25.4	1.2	2 600 100 211	P1b	1	1	433778

Reduction rings for circular saw blades
Base blade thickness of 1.7 mm up to max. 2.2 mm

20	16	1.5	2 600 100 212	P1b	1	1	433785
25	16	1.5	2 600 100 214	P1b	1	1	433808
25	20	1.5	2 600 100 215	P1b	1	1	433815
25.4	16	1.5	2 600 100 217	P1b	1	1	433839
25.4	20	1.5	2 600 100 219	P1b	1	1	433853
30	20	1.5	2 600 100 220	P1b	1	1	433860
30	25	1.5	2 600 100 221	P1b	1	1	433877
30	25.4	1.5	2 600 100 222	P1b	1	1	433884
35	30	1.5	2 600 100 225	P1b	1	1	433914

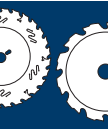

Reduction rings for circular saw blades

Diameter mm	Bore mm	Thickness mm	Part number	Packaging type	Pack quantity	Minimum order quantity	Barcode 3165140...
Product properties			Ordering information				

Reduction rings for circular saw blades

Base blade thickness of 2.2 mm up to max. 3.0 mm

25.4	16	1.8	2 600 100 227	P1b	1	1	433938
25.4	20	1.8	2 600 100 228	P1b	1	1	433945
30	20	1.8	2 600 100 230	P1b	1	1	433969
30	25	1.8	2 600 100 231	P1b	1	1	433976
30	25.4	1.8	2 600 100 232	P1b	1	1	433983

































Routing

New potential for hand-guided routers

Bosch offers a compact, clearly structured range of router bits for a wide range of applications. Power and precision characterise the routers from Bosch. Together with the new Expert and Standard router bits, they provide full system competence.

For demanding standard applications in the workshop and on the construction site. All Bosch router bits are made with durable carbide quality and are available in 8 and 12 mm shank diameters. Transparent range structure: router bits for profiling and router bits for joining.

	Expert ◆◆◆◆	Standard ◆◆◆
Precise bits for joining		
Straight bits, full carbide		
Straight bits		
Straight bits, one flute		
Hinge mortising bits		
Laminate trim bits with ball bearing pilot at top		
Laminate trim bits with ball bearing pilot at bottom		
Pilot panel bits		
Rebating bits with ball bearing pilot		
Dovetail bits		
Slotting cutters with ball bearing pilot		
Slotting cutters		
Shank for slotting cutter with ball bearing pilot		
Tongue jointing bits, two flutes		

	Expert ♦♦♦♦	Standard ♦♦♦
Shaping bits for profiling		
Core box bits, full carbide		
Core box bits		
Core box bits with ball bearing pilot		
Rounding over bits with ball bearing pilot		
Chamfer bits with ball bearing pilot		
V-groove bits		
Beading bits		
Guided staff bead bits with ball bearing pilot		
Staff bead bits		
Edge forming bits A with ball bearing pilot		
Edge forming bits B with ball bearing pilot		
Edge forming bits C with ball bearing pilot		
Edge forming bits D with ball bearing pilot		
Edge forming bits E		
Edge forming bits F with ball bearing pilot		
Edge forming bits G with ball bearing pilot		
Edge forming bits H		



Routing accessories		
Expert for Wood	Ball bearing pilot set	

Better results

when used in the right direction

Quality has a lot to do with the competence of the power tools and the precision of the router bits.

In addition to this, our practical experience can be communicated for the benefit of the customer.

Four-sided routing around workpieces

1 + 2: first of all, the face ends are routed

3 + 4: then the longitudinal edges are routed, along the grain

Advantage: Corners that are splintered when routing the face ends can be corrected.

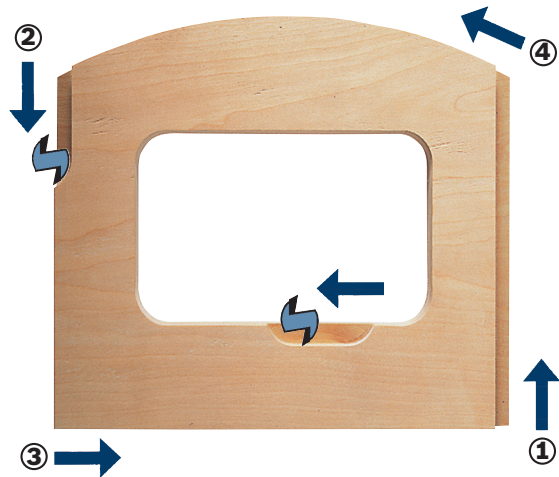

Routing curved edges

Suitable accessories for clean routing: pilot, ball bearing pilot or template with template guide.

Risks when working without a stop

If the router is pulled towards the user, it drifts to the right.
If the router is thrust away from the user, it drifts to the left.



Routing with a locating stop and routing grooves

The correct feed direction is crucial with regard to quality.

Routing with a locating stop: thrusting the router.

Groove cutting: routing in the counter direction.

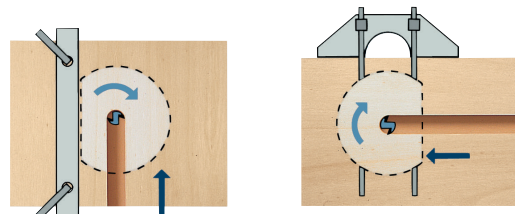

Safe upcut routing

When upcut routing is performed, the stop is cleanly pulled against the workpiece: safe and clean working.

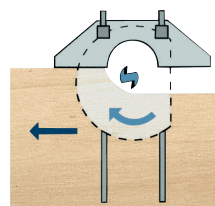

←
Upcut routing

Unsafe downcut routing

When downcut routing is performed, the machine is pressed away from the workpiece: unclean edges, risk of the machine drifting off.

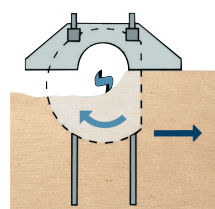

→
Downcut routing

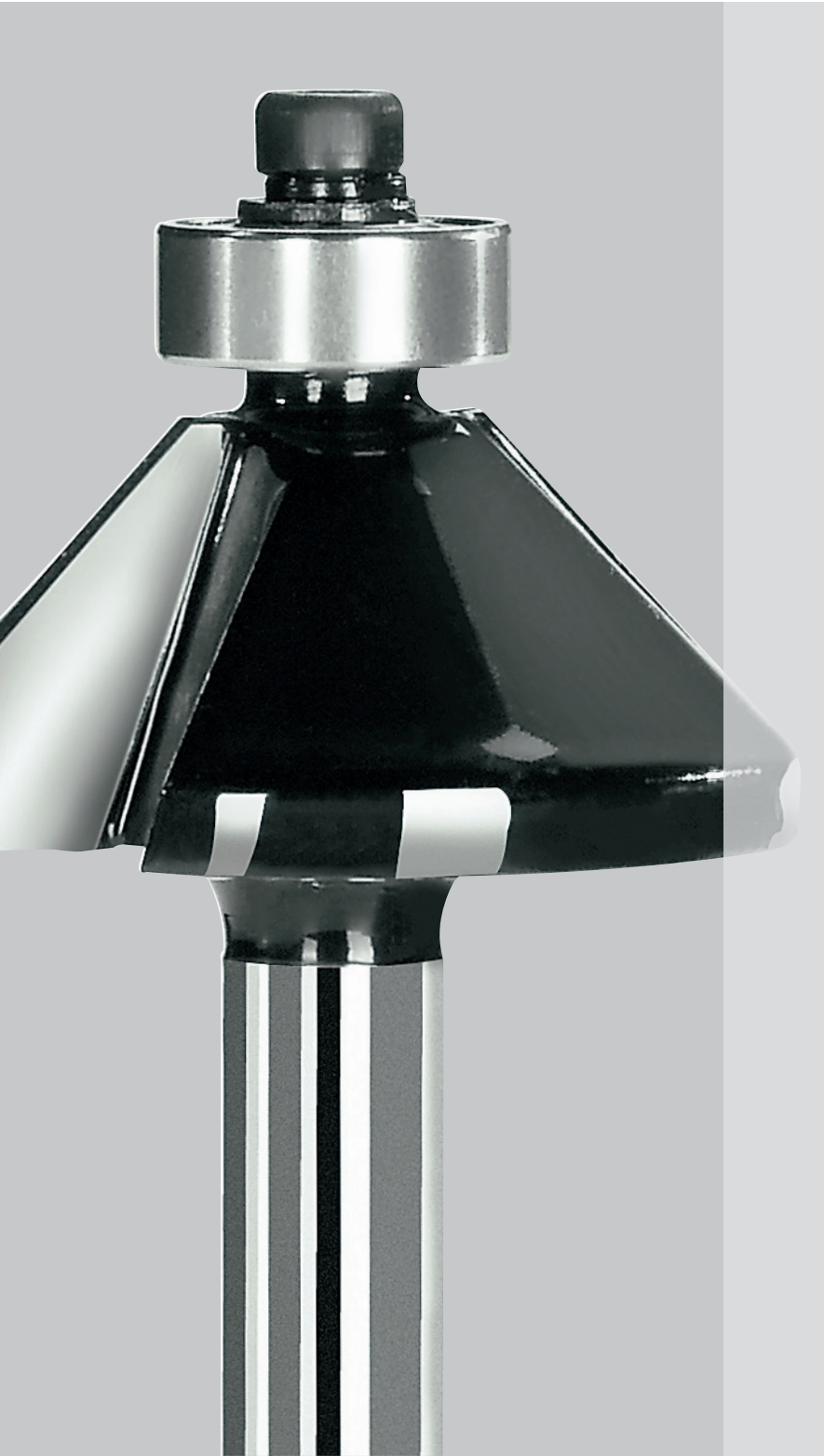

Standard ◆◆◆

Standard



Bosch Standard carbide router bits

All Bosch Standard router bits have high-quality carbide cutters, optimised cutting geometry and a precision cut that has been perfected through many years of experience. This enables a precise fit and long lifetime. Standard router bits from Bosch meet the latest European standard (EN standard 847).



Precise bits for joining

Straight bits

- ▶ For general routing, grooving or rebating with routers
- ▶ For formatting straight or curved workpieces
- ▶ One and two flute router bits

Straight bits, one flute, tungsten carbide

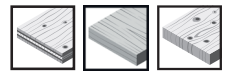

- ▶ For routing small grooves for chipboard tongue joints, for decorative grooves in surfaces or grooves in rubber seal profiles
- ▶ **Suitable for** solid wood and panel materials

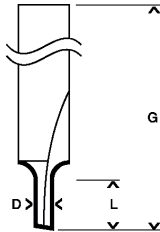

Product properties						Ordering information				
Shank mm	Diameter (D) mm	Width (B) mm	Working length (L) mm	Radius (R1) mm	Total length (G) mm	Part number	Packaging type	Pack quantity	Minimum order quantity	Barcode 3165140...
8	3	-	8	-	51	2 608 628 376	P2a	1	1	358378
8	4	-	8	-	51	2 608 628 377	P2a	1	1	358385
8	5	-	12.7	-	51	2 608 628 378	P2a	1	1	358392

Straight bits, two flutes, tungsten carbide



- **Suitable for** solid wood and board materials such as chipboard or MDF board, plastics or abrasive materials such as Corian.

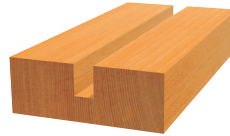
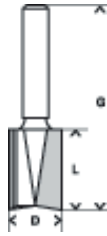
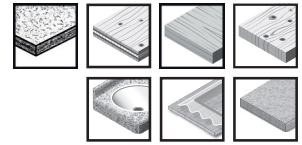

Shank mm		Diameter (D) mm		Width (B) mm		Working length (L) mm		Radius (R1) mm		Total length (G) mm		Part number		Packaging type		Pack quantity		Minimum order quantity		Barcode 3165140...	
Product properties										Ordering information											
8	6	-	16	-	48	2 608 628 379	P2a	1	1	358408											
8	7	-	20	-	51	2 608 628 380	P2a	1	1	358415											
8	8	-	20	-	51	2 608 628 381	P2a	1	1	358422											
8	9	-	20	-	51	2 608 628 382	P2a	1	1	358439											
8	10	-	20	-	51	2 608 628 383	P2a	1	1	358446											
8	11	-	20	-	51	2 608 628 384	P2a	1	1	358453											
8	12	-	20	-	51	2 608 628 385	P2a	1	1	358460											
8	13	-	20	-	51	2 608 628 386	P2a	1	1	358477											
8	14	-	20	-	51	2 608 628 375	P2a	1	1	358361											
8	15	-	20	-	51	2 608 628 387	P2a	1	1	358484											
8	16	-	20	-	51	2 608 628 388	P2a	1	1	358491											
8	18	-	25	-	56	2 608 628 389	P2a	1	1	358507											
8	20	-	25	-	56	2 608 628 390	P2a	1	1	358514											
8	22	-	25	-	56	2 608 628 391	P2a	1	1	358521											
8	25	-	20	-	51	2 608 628 392	P1a	1	1	358538											



Straight bits with extra length, two flutes, tungsten carbide



- ▶ Longer working length for greater flexibility in the application
- ▶ **Suitable for** solid wood and panel materials such as chipboard or MDF boards, plastics or abrasive materials such as Corian

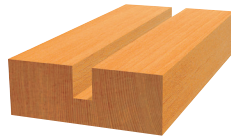
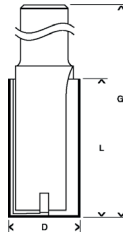
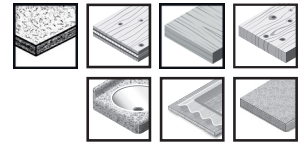

Shank mm	Diameter (D) mm	Width (B) mm	Working length (L) mm	Radius (R1) mm	Total length (G) mm	Part number	Packaging type	Pack quantity	Minimum order quantity	Barcode 3165140...
Product properties						Ordering information				
8	8	-	25.4	-	56	2 608 628 372	P2a	1	1	358330
8	10	-	25.4	-	56	2 608 628 373	P2a	1	1	358347
8	12	-	32	-	62	2 608 628 374	P2a	1	1	358354
12	10	-	40	-	81	2 608 628 464	P2a	1	1	420273
12	12	-	40	-	81	2 608 628 465	P2a	1	1	420280
12	16	-	40	-	81	2 608 628 466	P2a	1	1	420297
12	18	-	40	-	81	2 608 628 467	P2a	1	1	420303
12	20	-	40	-	81	2 608 628 468	P2a	1	1	420310
12	25	-	40	-	81	2 608 628 469	P2a	1	1	420327
12	30	-	40	-	81	2 608 628 470	P2a	1	1	420334

Hinge mortising bits

- ▶ For mortising shallow grooves for hinges or other furniture fittings
- ▶ The special shape of this bit ensures good chip clearance, quiet running and high-quality cutting

Hinge mortising bit, two flutes, tungsten carbide

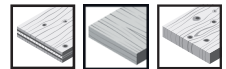

▶ **Suitable for** solid wood or board materials

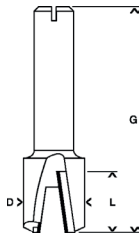

Standard
◆◆◆

Product properties					Ordering information					
Shank mm	Diameter (D) mm	Width (B) mm	Working length (L) mm	Radius (R1) mm	Total length (G) mm	Part number	Packaging type	Pack quantity	Minimum order quantity	Barcode 3165140...
8	12.7	- 12.7	- 50.8			2 608 628 399	P2a	1	1	358606

Pilot panel bits

- ▶ For through-drilling or quick cutouts of openings in shop fitting, exhibition fitting, caravan fitting and general construction work, e.g. cutouts for light switches, sockets, etc. in panel walls
- ▶ Router bit with tungsten carbide cutting edge (“light-switch cutout bit”)
- ▶ The bit shaft between the main cutter and the cutting edge guides the router bit along the workpiece

Pilot panel bit, tungsten carbide

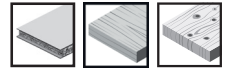

- ▶ **Suitable for** laminated workpieces made of wooden materials or solid wood

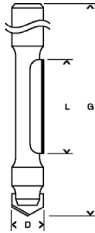

Product properties						Ordering information				
Shank mm	Diameter (D) mm	Width (B) mm	Working length (L) mm	Radius (R1) mm	Total length (G) mm	Part number	Packaging type	Pack quantity	Minimum order quantity	Barcode 3165140...
8	8	-	19	-	66	2 608 628 371	P2a	1	1	358323

Laminate trim bits

- ▶ For flush trimming and chamfering laminated boards, wood beams, corner beads in furniture manufacture and shop fitting
- ▶ With ball bearing pilot for easy guiding directly on the workpiece without a template

Laminate trim bits with ball bearing pilot, two flutes, tungsten carbide

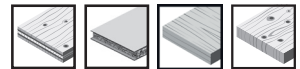

- ▶ **Suitable** for solid wood and abrasive board materials.

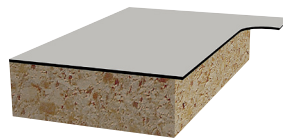
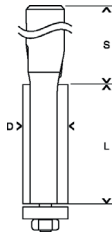

Standard
◆◆◆

	Shank mm	Diameter (D) mm	Width (B) mm	Working length (L) mm	Radius (R1) mm	Total length (G) mm	Part number	Packaging type	Pack quantity	Minimum order quantity	Barcode 3165140...	
Product properties							Ordering information					
8	9.5	-	25.4	-	68	2 608 628 346	P2a	1	1	358071		
8	12.7	-	13	-	56	2 608 628 347	P2a	1	1	358088		
8	12.7	-	25.4	-	68	2 608 628 348	P2a	1	1	358095		

Rebating bits

- ▶ For manufacturing furniture and frames (windows, doors, pictures)
- ▶ With ball bearing pilot for easy guiding directly on the workpiece without a template

Rebating bits with ball bearing pilot, two flutes, tungsten carbide

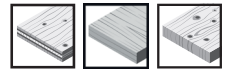

▶ **Suitable for** solid wood and board materials.

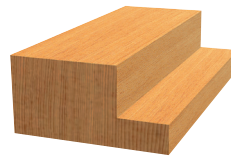
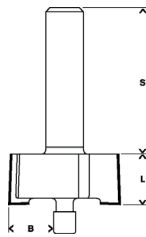

Shank mm	Diameter (D) mm	Width (B) mm	Working length (L) mm	Radius (R1) mm	Total length (G) mm	Part number	Packaging type	Pack quantity	Minimum order quantity	Barcode 3165140...
8	31.8	9.5	12.5	-	54	2 608 628 350	P2a	1	1	358118

Dovetail bits

- ▶ For the production of dovetail joints
- ▶ For open or concealed dovetails
- ▶ For semi-concealed dovetails in conjunction with dovetail jig
- ▶ For routing precise grooves, e.g. within a solid wood table to prevent warping

Dovetail bit, two flutes, tungsten carbide

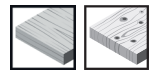

▶ Suitable for solid wood

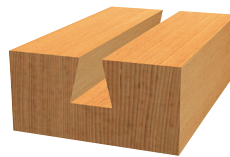
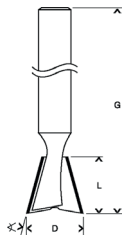

Standard
◆◆◆

Product properties					Ordering information					
Shank mm	Width (B) mm	Diameter (D) mm	Working length (L) mm	Total length (G) mm	Angle degrees	Part number	Packaging type	Pack quantity	Minimum order quantity	Barcode
8	-	14	14	55	15	2 608 628 408	P1a	1	1	358699

Slotting cutters

- ▶ For positioning grooves in narrow edges, e.g. to hold seals or for tongue and groove joints
- ▶ Slotting cutters for making grooves in narrow edges
- ▶ **Note:** Router guide fence created by the workpiece prevents the tool from turning over

Slotting cutters with ball bearing pilot, two flutes, tungsten carbide

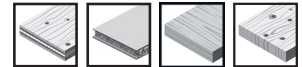

- ▶ **Suitable for** solid wood and panel materials

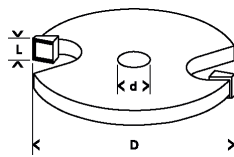

Product properties						Ordering information				
Shank mm	Diameter (D) mm	Width (B) mm	Working length (L) mm	Radius (R1) mm	Total length (G) mm	Part number	Packaging type	Pack quantity	Minimum order quantity	Barcode 3165140...
8	32	-	3	-	51	2 608 628 401	P1a	1	1	358620
8	32	-	4	-	51	2 608 628 402	P1a	1	1	358637
8	32	-	5	-	51	2 608 628 403	P1a	1	1	358644
8	32	-	6	-	51	2 608 628 404	P1a	1	1	358651

Tongue jointing bits

- For routing classical tongue and groove profiles in solid wood edges in combination with a 5 mm slotting cutter

Tongue jointing bit, two flutes, tungsten carbide

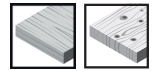

- Suitable for solid wood

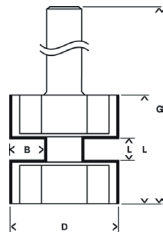

Standard
◆◆◆

Product properties					Ordering information					
Shank mm	Diameter (D) mm	Width (B) mm	Working length (L) mm	Radius (R1) mm	Total length (G) mm	Part number	Packaging type	Pack quantity	Minimum order quantity	Barcode 3165140...
8	25	-	5	-	58	2 608 628 353	P1a	1	1	358149

Shaping bits for profiling

Rounding over bits

- ▶ For rounding off edges, e.g. on windows, cupboards, table tops, shelves, fireplace surrounds
- ▶ With ball bearing pilot for easy guiding directly on the workpiece without a template
- ▶ Bosch rounding over bits for clean rounded edges

Rounding over bits with ball bearing pilot, two flutes, tungsten carbide

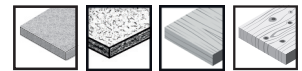

- ▶ **Suitable for** solid woods such as spruce, beech, oak, alder and abrasive materials.

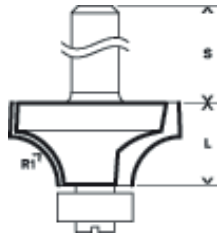

Shank mm	Diameter (D) mm	Radius (R1) mm	Working length (L) mm	Total length (G) mm	Part number	Packaging type	Pack quantity	Minimum order quantity	Barcode 31 65140...
Product properties					Ordering information				
8	-	3	10.2	53	2 608 628 344	P2a	1	1	358057
8	-	4	10.5	53	2 608 628 339	P2a	1	1	358002
8	-	6	13.2	53	2 608 628 340	P1a	1	1	358019
8	-	8	15.2	53	2 608 628 341	P1a	1	1	358026
8	-	10	16.5	57	2 608 628 342	P1a	1	1	358033
8	-	12	19	60	2 608 628 343	P1a	1	1	358040
8	-	15	22	66	2 608 628 345	P1a	1	1	358064
12	-	12	19	70	2 608 628 471	P2a	1	1	420342

Chamfer bits

- ▶ For chamfering edges on straight or curved workpieces
- ▶ With ball bearing pilot for easy guiding directly on the workpiece without a template
- ▶ Chamfer bits for fine decorative chamfers on furniture

Chamfer bits with ball bearing pilot, two flutes, tungsten carbide

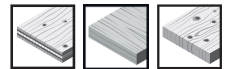

- ▶ **Suitable for** solid wood and board materials

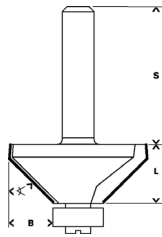

Standard
◆◆◆

Product properties					Ordering information				
Shank mm	Width (B) mm	Working length (L) mm	Total length (G) mm	Angle degrees	Part number	Packaging type	Pack quantity	Minimum order quantity	Barcode 3165140...
8	11	15	56	45	2 608 628 352	P1a	1	1	358132

Chamfer/laminate trim bits with ball bearing pilot, two flutes, tungsten carbide

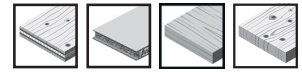

- ▶ For flush trimming and chamfering laminated boards, wood beams, corner beads in furniture manufacture and shop fitting
- ▶ **Suitable for** laminated workpieces made of wood-based materials, solid wood and panel materials

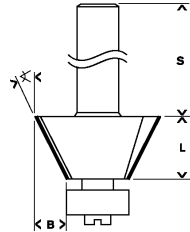

Product properties						Ordering information					
Shank mm	Width (B) mm	Diameter (D) mm	Working length (L) mm	Total length (G) mm	Angle degrees	Part number	Packaging type	Pack quantity	Minimum order quantity	Barcode	3165140...
8	5.5	23.7	12	54	25	2 608 628 351	P1a	1	1	358125	

Core box bits

- ▶ For producing edge profiles, hinge connections with core box profiles, decorative grooves, sauce channels on serving platters, structuring surfaces and for use in copy routing machines
- ▶ Bosch core box bits for surface structures

Core box bits, two flutes, tungsten carbide

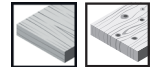

- ▶ **Suitable for soft and hard solid wood**

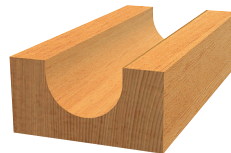
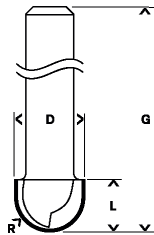

Standard
◆◆◆

Shank mm		Diameter (D) mm	Total length (G) mm	Working length (L) mm	Radius (R1) mm	Part number	Packaging type	Pack quantity	Minimum order quantity	Barcode 3165140...
Product properties					Ordering information					
8	8	40	9.2	4	2 608 628 367	P2a	1	1	358286	
8	12	40	9.2	6	2 608 628 368	P2a	1	1	358293	
8	16	45	12.4	8	2 608 628 369	P2a	1	1	358309	
8	20	46	12.4	10	2 608 628 370	P2a	1	1	358316	
12	16	54	12.7	8	2 608 628 472	P2a	1	1	420358	
12	24	57	15.9	12	2 608 628 473	P2a	1	1	420365	

Core box bits with ball bearing pilot, two flutes, tungsten carbide

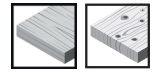

- ▶ Core box bits with ball bearing pilot for easy guiding directly on the workpiece without a template
- ▶ **Suitable for** soft and hard solid wood

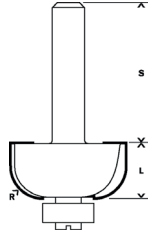

	Shank mm	Diameter (D) mm	Total length (G) mm	Working length (L) mm	Radius (R1) mm	Part number	Packaging type	Pack quantity	Minimum order quantity	Barcode 3165140...	
Product properties						Ordering information					
8	20.7	53	9	4	2 608 628 361	P2a	1	1	358224		
8	24.7	53	13	6	2 608 628 362	P1a	1	1	358231		
8	28.7	54	13	8	2 608 628 363	P1a	1	1	358248		
8	32.7	55	14	10	2 608 628 364	P1a	1	1	358255		
8	36.7	58	16	12	2 608 628 365	P1a	1	1	358262		
12	36.7	70	16	12	2 608 628 474	P2a	1	1	420372		

V-groove bits

- ▶ For carving fine lettering and decorative grooves
- ▶ Also for chamfering edges when used with parallel guide or template guide

V-groove bits, two flutes, tungsten carbide

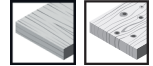

▶ Suitable for solid wood

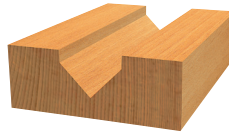
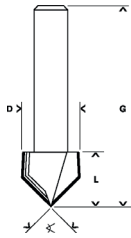

Standard
◆◆◆

Shank mm	Diameter (D) mm	Working length (L) mm	Total length (G) mm	Angle degrees	Part number	Packaging type	Pack quantity	Minimum order quantity	Barcode 3165140...
Product properties					Ordering information				
8	11	14	45	60	2 608 628 406	P2a	1	1	358675
8	16	16	45	90	2 608 628 407	P2a	1	1	358682

Beading bits

- ▶ For decorative edges in furniture manufacture or interior fitting work
- ▶ For imitation of tongue and groove joints in solid wood surfaces (if the full working length of the router bit is not used)
- ▶ For imitation of frame constructions with filling (full working length of the router bit used)

Beading bit, one flute, tungsten carbide

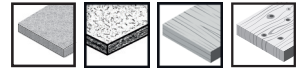

▶ **Suitable for** solid wood and abrasive materials

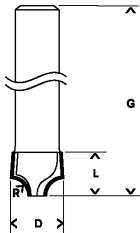

Product properties					Ordering information					
Shank mm	Diameter (D) mm		Working length (L) mm	Radius (R1) mm	Total length (G) mm	Part number	Packaging type	Pack quantity	Minimum order quantity	Barcode
8	9.5	10.2	3.2	41	2 608 628 405	P2a	1	1	358668	3165140...

Guided staff bead bits

- ▶ For decorative edging of solid wood in furniture manufacture, frame construction, interior fitting work
- ▶ Particularly suitable for routing the profile “guided staff”
- ▶ With ball bearing pilot for easy guiding of the router bit directly along the workpiece without a template

Guided staff bead bits with ball bearing pilot, carbide

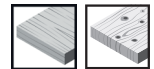

▶ Suitable for solid wood

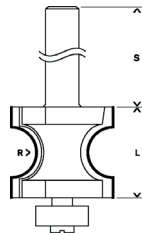

Standard
◆◆◆

Product properties			Ordering information							
Shank mm	Width (B) mm	Diameter (D) mm	Working length (L) mm	Radius (R1) mm	Total length (G) mm	Part number	Packaging type	Pack quantity	Minimum order quantity	Barcode 3165140...
8	-	-	19	6	63	2 608 628 360	P1a	1	1	358217

Staff bead bits

Staff bead bit, two flutes, in tungsten carbide version

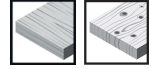

► Suitable for soft and hard solid wood

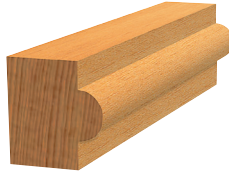
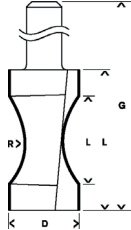

Product properties					Ordering information					
Shank mm	Width (B) mm	Diameter (D) mm	Working length (L) mm	Radius (R1) mm	Total length (G) mm	Part number	Packaging type	Pack quantity	Minimum order quantity	Barcode
8	20.6	32	18.3	63.5	2 608 628 354	P1a	1	1	358156	3165140...

Edge forming bits

- ▶ For producing decorative edges on shelves and frames, and for designing mantelpieces and frame profiles
- ▶ With ball bearing pilot for easy guiding along the workpiece
- ▶ Bosch edge forming bits for perfect furniture joinery work

Edge forming bit A with ball bearing pilot, two flutes, tungsten carbide

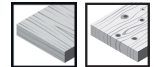

▶ **Suitable for** soft and hard solid wood

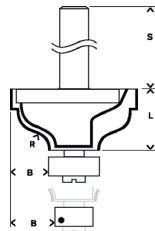

Standard
◆◆◆

Product properties						Ordering information				
Shank mm	Width (B) mm	Diameter (D) mm	Working length (L) mm	Radius (R1) mm	Total length (G) mm	Part number	Packaging type	Pack quantity	Minimum order quantity	Barcode 3165140...
8	11	-	14.3	4.8	57	2 608 628 393	P1a	1	1	358545

Edge forming bit B with ball bearing pilot, two flutes, tungsten carbide

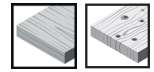

► Suitable for soft and hard solid wood

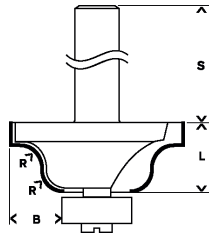

Product properties						Ordering information				
Shank mm	Width (B) mm	Diameter (D) mm	Working length (L) mm	Radius (R1) mm	Total length (G) mm	Part number	Packaging type	Pack quantity	Minimum order quantity	Barcode 3165140...
8	8	-	12.4	4	54	2 608 628 394	P1a	1	1	358552
8	12.7	-	17	6.3	61	2 608 628 395	P1a	1	1	358569

Edge forming bit C with ball bearing pilot, two flutes, tungsten carbide

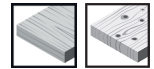

► Suitable for soft and hard solid wood

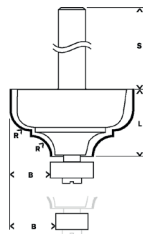

8	9.5	-	14	4.8	57	2 608 628 396	P1a	1	1	358576
---	-----	---	----	-----	----	----------------------	-----	---	---	--------

Edge forming bit D with ball bearing pilot, two flutes, tungsten carbide

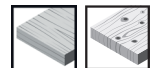

► Suitable for soft and hard solid wood

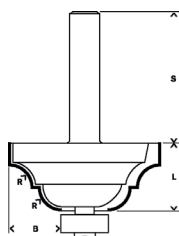

8	15	-	18	6.3	60	2 608 628 397	P1a	1	1	358583
---	----	---	----	-----	----	----------------------	-----	---	---	--------

Edge forming bit E, two flutes, tungsten carbide

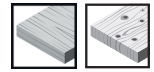

► Suitable for soft and hard solid wood

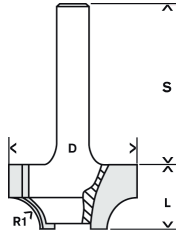

Product properties					Ordering information					
Shank mm	Width (B) mm	Diameter (D) mm	Working length (L) mm	Radius (R1) mm	Total length (G) mm	Part number	Packaging type	Pack quantity	Minimum order quantity	Barcode 3165140...
8	- 25.4	14	6.3	46	2 608 628 355	P1a	1	1	358163	

Edge forming bit F with ball bearing pilot, two flutes, tungsten carbide

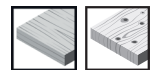

Standard
◆◆◆



► Suitable for soft and hard solid wood

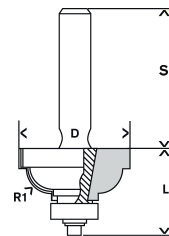

8	- 28.5	13.2	6.3	54	2 608 628 356	P1a	1	1	358170
8	- 35	16.2	9.5	59	2 608 628 358	P1a	1	1	358194

Edge forming bit G with ball bearing pilot, two flutes, tungsten carbide

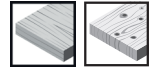

► Suitable for soft and hard solid wood

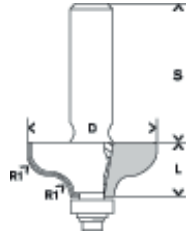

Product properties						Ordering information				
Shank mm	Width (B) mm	Diameter (D) mm	Working length (L) mm	Radius (R1) mm	Total length (G) mm	Part number	Packaging type	Pack quantity	Minimum order quantity	Barcode 3165140...
8	-	31.8	12.4	4.8	54	2 608 628 357	P1a	1	1	358187
8	-	38	15.7	6.35	57	2 608 628 359	P1a	1	1	358200

Edge forming bit H, two flutes, tungsten carbide

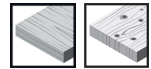

► Suitable for soft and hard solid wood

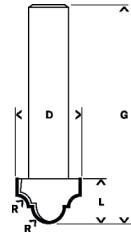

8	-	12.7	12.4	2.4	46	2 608 628 398	P2a	1	1	358590
---	---	------	------	-----	----	----------------------	-----	---	---	--------

Accessories for Bosch universal routers and biscuit jointers

Blade cutters, 105 mm diameter, for Bosch universal router



- ▶ For cutting grooves, biscuit joints and flat dowels in wood.
- ▶ Easy production of country style look with the versatile Bosch universal router and the appropriate Bosch straight bit.

Diameter mm	Number of teeth	Width mm	Part number	Packaging type	Pack quantity	Minimum order quantity	Barcode 3165140...
Product properties			Ordering information				

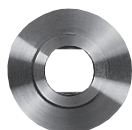

Backing flange
Appropriate for GFF 22 A Professional

-	-	-	3 605 700 155	P1c	1	1	184380
---	---	---	----------------------	-----	---	---	--------



Blade cutter
Appropriate for GUF 4-22 A Professional; PSF 22 A

105	8	4	3 608 641 008	C1c	1	1	013802
------------	---	---	----------------------	-----	---	---	--------



Blade cutter
Appropriate for GUF 4-22 A Professional; PSF 22 A

20	10	2.8	3 608 641 001	C1c	1	1	012546
-----------	----	-----	----------------------	-----	---	---	--------



Blade cutter
for Universal Router GUF 4-22 A, Wall Chaser PSF 22 A, only together with backing flange 3 605 700 155 also for Biscuit Jointer GFF 22 A
Appropriate for GOF 900 A; GOF 900 ACE; GOF 1200 A; GOF 1300 ACE Professional; POF 800 ACE; POF 1100; POF 1300

20	22	2.8	3 608 641 002	C1c	1	1	012560
-----------	----	-----	----------------------	-----	---	---	--------



Blade cutter
Appropriate for GFF 22 A Professional

105	8	4	3 608 641 013	C1c	1	1	184359
------------	---	---	----------------------	-----	---	---	--------



Biscuit dowels for Bosch biscuit jointer



► For perfect joints.

Length mm	Width mm	Height mm	Part number	Packaging type	Pack quantity	Minimum order quantity	Barcode 3165140...
Product properties			Ordering information				



Biscuit dowels GR 0

45	15	4	2 607 000 796	P1d	50	1	081443
45	15	4	2 607 000 147	C0a	1000	1	032971

Biscuit dowels GR 10

55	19	4	2 607 000 797	P1d	50	1	093880
55	19	4	2 607 000 148	C0a	1000	1	032988

Biscuit dowels GR 20

60	23	4	2 607 000 103	P1d	50	1	012829
60	23	4	2 607 000 149	C0a	1000	1	032995

Part number index

Part number	Page	MOQ*	Part number	Page	MOQ*	Part number	Page	MOQ*	Part number	Page	MOQ*
2600 100 185	65	1	2608 628 387	74	1	2608 640 615	46	1	2608 641 184	46	1
2600 100 186	65	1	2608 628 388	74	1	2608 640 616	46	1	2608 641 185	46	1
2600 100 187	65	1	2608 628 389	74	1	2608 640 617	46	1	2608 641 186	46	1
2600 100 188	65	1	2608 628 390	74	1	2608 640 618	46	1	2608 641 187	46	1
2600 100 192	65	1	2608 628 391	74	1	2608 640 620	47	1	2608 641 188	46	1
2600 100 193	65	1	2608 628 392	74	1	2608 640 621	47	1	2608 641 190	47	1
2600 100 194	65	1	2608 628 393	92	1	2608 640 622	47	1	2608 641 192	47	1
2600 100 195	65	1	2608 628 394	93	1	2608 640 623	47	1	2608 641 195	53	1
2600 100 197	65	1	2608 628 395	93	1	2608 640 627	47	1	2608 641 199	51	1
2600 100 201	65	1	2608 628 396	93	1	2608 640 628	47	1	2608 641 200	51	1
2600 100 202	65	1	2608 628 397	93	1	2608 640 629	47	1	2608 641 201	51	1
2600 100 203	65	1	2608 628 398	95	1	2608 640 630	51	1	2608 641 202	48	1
2600 100 207	65	1	2608 628 399	76	1	2608 640 632	51	1	2608 641 204	54	1
2600 100 208	65	1	2608 628 401	81	1	2608 640 633	51	1	2608 641 765	48	1
2600 100 209	65	1	2608 628 402	81	1	2608 640 634	51	1	2608 641 768	48	1
2600 100 210	65	1	2608 628 403	81	1	2608 640 635	51	1	2608 641 769	48	1
2600 100 211	65	1	2608 628 404	81	1	2608 640 636	51	1	2608 641 771	48	1
2600 100 212	65	1	2608 628 405	89	1	2608 640 641	47	1	2608 641 774	52	1
2600 100 214	65	1	2608 628 406	88	1	2608 640 642	47	1	2608 642 096	19	1
2600 100 215	65	1	2608 628 407	88	1	2608 640 643	47	1	2608 642 097	19	1
2600 100 217	65	1	2608 628 408	80	1	2608 640 644	47	1	2608 642 098	19	1
2600 100 219	65	1	2608 628 464	75	1	2608 640 645	47	1	2608 642 099	19	1
2600 100 220	65	1	2608 628 465	75	1	2608 640 651	48	1	2608 642 100	14	1
2600 100 221	65	1	2608 628 466	75	1	2608 640 660	48	1	2608 642 101	14	1
2600 100 222	65	1	2608 628 467	75	1	2608 640 665	48	1	2608 642 102	14	1
2600 100 225	65	1	2608 628 468	75	1	2608 640 670	48	1	2608 642 103	14	1
2600 100 227	66	1	2608 628 469	75	1	2608 640 672	48	1	2608 642 104	16	1
2600 100 228	66	1	2608 628 470	75	1	2608 640 673	48	1	2608 642 105	17	1
2600 100 230	66	1	2608 628 471	83	1	2608 640 674	48	1	2608 642 106	16	1
2600 100 231	66	1	2608 628 472	86	1	2608 640 675	48	1	2608 642 107	17	1
2600 100 232	66	1	2608 628 473	86	1	2608 640 680	50	1	2608 642 108	16	1
2607 000 103	97	1	2608 628 474	87	1	2608 640 681	50	1	2608 642 109	16	1
2607 000 147	97	1	2608 640 430	47	1	2608 640 682	50	1	2608 642 110	16	1
2607 000 148	97	1	2608 640 431	47	1	2608 640 683	50	1	2608 642 111	15	1
2607 000 149	97	1	2608 640 432	47	1	2608 640 684	50	1	2608 642 112	15	1
2607 000 796	97	1	2608 640 433	47	1	2608 640 690	52	1	2608 642 113	15	1
2607 000 797	97	1	2608 640 434	47	1	2608 640 691	52	1	2608 642 114	15	1
2608 628 339	83	1	2608 640 435	47	1	2608 640 692	52	1	2608 642 115	15	1
2608 628 340	83	1	2608 640 436	47	1	2608 640 693	52	1	2608 642 116	15	1
2608 628 341	83	1	2608 640 437	47	1	2608 640 694	52	1	2608 642 117	15	1
2608 628 342	83	1	2608 640 438	47	1	2608 640 695	52	1	2608 642 118	15	1
2608 628 343	83	1	2608 640 440	48	1	2608 640 700	52	1	2608 642 119	15	1
2608 628 344	83	1	2608 640 441	48	1	2608 640 701	52	1	2608 642 120	15	1
2608 628 345	83	1	2608 640 442	48	1	2608 640 702	52	1	2608 642 121	15	1
2608 628 346	78	1	2608 640 443	47	1	2608 640 703	52	1	2608 642 122	15	1
2608 628 347	78	1	2608 640 444	48	1	2608 640 704	52	1	2608 642 123	15	1
2608 628 348	78	1	2608 640 445	54	1	2608 640 705	52	1	2608 642 124	15	1
2608 628 350	79	1	2608 640 446	54	1	2608 640 725	47	1	2608 642 125	15	1
2608 628 351	85	1	2608 640 447	54	1	2608 640 727	47	1	2608 642 126	18	1
2608 628 352	84	1	2608 640 449	54	1	2608 640 728	47	1	2608 642 127	18	1
2608 628 353	82	1	2608 640 450	54	1	2608 640 729	47	1	2608 642 128	18	1
2608 628 354	91	1	2608 640 451	54	1	2608 640 732	46	1	2608 642 129	18	1
2608 628 355	94	1	2608 640 452	54	1	2608 640 761	52	1	2608 642 130	18	1
2608 628 356	94	1	2608 640 453	54	1	2608 640 762	52	1	2608 642 131	18	1
2608 628 357	95	1	2608 640 501	53	1	2608 640 770	54	1	2608 642 133	20	1
2608 628 358	94	1	2608 640 503	53	1	2608 640 774	49	1	2608 642 135	20	1
2608 628 359	95	1	2608 640 506	53	1	2608 640 775	49	1	2608 642 137	20	1
2608 628 360	90	1	2608 640 507	53	1	2608 640 781	49	1	2608 642 384	14	1
2608 628 361	87	1	2608 640 508	53	1	2608 640 784	49	1	2608 642 385	14	1
2608 628 362	87	1	2608 640 509	53	1	2608 640 785	49	1	2608 642 386	14	1
2608 628 363	87	1	2608 640 510	53	1	2608 640 786	49	1	2608 642 387	19	1
2608 628 364	87	1	2608 640 511	53	1	2608 640 787	49	1	2608 642 388	19	1
2608 628 365	87	1	2608 640 513	53	1	2608 640 789	49	1	2608 642 492	35	1
2608 628 367	86	1	2608 640 514	53	1	2608 640 795	49	1	2608 642 493	35	1
2608 628 368	86	1	2608 640 516	54	1	2608 640 799	49	1	2608 642 494	35	1
2608 628 369	86	1	2608 640 518	54	1	2608 640 800	49	1	2608 642 495	35	1
2608 628 370	86	1	2608 640 519	53	1	2608 640 801	49	1	2608 642 496	26	1
2608 628 371	77	1	2608 640 582	46	1	2608 640 803	49	1	2608 642 497	26	1
2608 628 372	75	1	2608 640 583	46	1	2608 640 804	49	1	2608 642 498	26	1
2608 628 373	75	1	2608 640 586	46	1	2608 640 805	49	1	2608 642 499	26	1
2608 628 374	75	1	2608 640 592	46	1	2608 640 807	49	1	2608 642 500	27	1
2608 628 375	74	1	2608 640 593	46	1	2608 640 815	53	1	2608 642 501	27	1
2608 628 376	73	1	2608 640 596	46	1	2608 640 817	46	1	2608 642 502	28	1
2608 628 377	73	1	2608 640 597	46	1	2608 640 818	46	1	2608 642 503	28	1
2608 628 378	73	1	2608 640 602	46	1	2608 641 167	46	1	2608 642 504	28	1
2608 628 379	74	1	2608 640 603	46	1	2608 641 168	46	1	2608 642 505	28	1
2608 628 380	74	1	2608 640 608	46	1	2608 641 169	46	1	2608 642 506	28	1
2608 628 381	74	1	2608 640 609	46	1	2608 641 170	46	1	2608 642 507	28	1
2608 628 382	74	1	2608 640 610	46	1	2608 641 171	46	1	2608 642 508	29	1
2608 628 383	74	1	2608 640 611	46	1	2608 641 172	46	1	2608 642 509	29	1
2608 628 384	74	1	2608 640 612	46	1	2608 641 173	46	1	2608 642 510	29	1
2608 628 385	74	1	2608 640 613	46	1	2608 641 175	46	1	2608 642 511	29	1
2608 628 386	74	1	2608 640 614	46	1	2608 641 181	46	1	2608 642 512	29	1

Part number	Page	MOQ*
2 608 642 513	29	1
2 608 642 514	32	1
2 608 642 515	32	1
2 608 642 516	33	1
2 608 642 517	33	1
2 608 642 518	33	1
2 608 642 528	35	1
2 608 642 529	35	1
2 608 642 530	26	1
2 608 642 531	26	1
2 608 642 600	49	1
2 608 642 601	49	1
2 608 642 602	46	1
2 608 642 606	18	1
2 608 642 607	18	1
2 608 642 608	18	1
2 608 642 609	18	1
2 608 642 610	18	1
2 608 643 054	40	1
2 608 643 055	40	1
2 608 643 056	40	1
2 608 643 057	40	1
2 608 643 058	40	1
2 608 643 059	41	1
2 608 643 060	41	1
2 608 643 061	41	1
2 608 643 062	41	1
2 608 643 063	41	1
2 608 643 071	46	1
2 608 644 022	25	1
2 608 644 023	25	1
2 608 644 024	24	1
2 608 644 047	25	1
2 608 644 048	25	1
2 608 644 049	24	1
2 608 644 050	24	1
2 608 644 064	25	1
2 608 644 065	25	1
2 608 644 066	24	1
2 608 644 079	26	1
2 608 644 080	26	1
2 608 644 081	26	1
2 608 644 082	26	1
2 608 644 083	27	1
2 608 644 084	27	1
2 608 644 085	27	1
2 608 644 086	27	1
2 608 644 087	27	1
2 608 644 088	27	1
2 608 644 089	27	1
2 608 644 090	27	1
2 608 644 091	27	1
2 608 644 095	36	1
2 608 644 102	36	1
2 608 644 107	36	1
2 608 644 109	37	1
2 608 644 110	37	1
2 608 644 111	38	1
2 608 644 112	38	1
2 608 644 113	38	1
2 608 644 114	38	1
2 608 644 115	38	1
2 608 644 116	38	1
2 608 644 117	39	1
2 608 644 118	39	1
2 608 644 119	39	1
2 608 644 122	43	1
2 608 644 125	43	1
2 608 644 128	31	1
2 608 644 130	31	1
2 608 644 133	34	1
2 608 644 135	34	1
2 608 644 137	30	1
2 608 644 139	30	1
2 608 644 143	42	1
3 605 700 155	96	1
3 608 641 001	96	1
3 608 641 002	96	1
3 608 641 008	96	1
3 608 641 013	96	1

Date of production or packing

Encrypted month codes

	2005	2006	2007	2008	2009	2010	2011	2012	2013	2014	2015
January	581	681	781	881	981	001	101	201	301	417	517
February	582	682	782	882	982	002	102	202	302	418	518
March	583	683	783	883	983	003	103	203	303	419	519
April	584	684	784	884	984	004	104	204	304	420	520
May	585	685	785	885	985	005	105	205	305	453	553
June	586	686	786	886	986	006	106	206	306	454	554
July	587	687	787	887	987	007	107	207	307	455	555
August	588	688	788	888	988	008	108	208	308	456	556
September	589	689	789	889	989	009	109	209	309	457	557
October	590	690	790	890	990	010	110	210	310	458	558
November	591	691	791	891	991	011	111	211	311	459	559
December	592	692	792	892	992	012	112	212	312	460	560



The Bosch ordering and packaging control system

The ordering and packaging control system makes it easier to order the right amount and find the packaging type at a glance.

Order quantities are rounded up to the minimum order quantity.

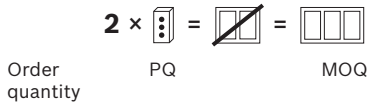

Order quantities must be a multiple of the minimum order quantity: 3, 6, 9, etc.

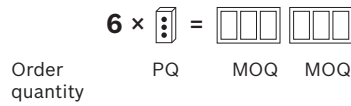

Example:

Step 1: The packaging type for each part number can be found on the product pages:

Part number	Packaging type	Pack quantity	Minimum order quantity ¹	Barcode 3165140...
2 608 585 780	P1p	1	1	511421
2 608 585 781	P1p	1	1	511438

Step 2: An illustration of the corresponding packaging type and specifications about the type of suspension and form of the packaging can be found on the back cover.



P1p Watchbox with Euro hole

P2p Watchbox with other type of suspension

Step 3: What is the structure of a packaging type code?



1. There are six different material groups which are identified by the initial letter in the English packaging code:

- Packaging made of paper, cardboard or corrugated board (**C**ardboard)
- Plastic packaging (**P**lastic)
- Combined plastic / cardboard packaging (**P**lastic and **C**ardboard)
- Metal packaging (**M**etal)
- Unpacked product (**U**npacked)
- Wood packaging (**W**ood)

2. Each packaging has one of three different types of suspension:

- 0 without any type of suspension
- 1 with Euro hole
- 2 other type of suspension

3. In the six material groups, each form of packaging is identified by a lower case letter:

C Packaging made of paper, cardboard or corrugated board

- a Box
- b Folded carton
- c Pocket
- d Sleeve
- e Hanger
- f Paper bag
- h Tube
- k Carton with sleeve

P Plastic packaging

- a Box
- b Bag
- c Pouch
- d Bag with tab card
- e Hanger
- f Shrink-wrapped
- h Tube
- k Cassette
- n Sleeve
- p Watchbox

PC Combined plastic / cardboard packaging

- a Blister
- b Folding blister
- c Shrink-wrapped carton
- d Tight Pack

M Metal packaging

- a Cassette
- b Aerosol

U Unpacked product

No form specifications

W Wood packaging

- a Case



Packaging

that conveys clear information

Packaging made of paper, cardboard or corrugated board (**Cardboard**)



C0a Box without any type of suspension



C1a Box with Euro hole



C2a Box with other type of suspension



C1b Folded carton with Euro hole

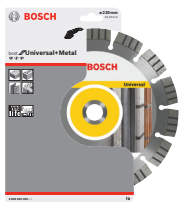

C1c Pocket with Euro hole



C1d Sleeve with Euro hole



C1e Hanger with Euro hole



C0f Paper bag without any type of suspension



C0h Tube without any type of suspension



C2h Tube with other type of suspension



C1k Carton with sleeve and Euro hole

Plastic packaging (Plastic)



P0a Box without any type of suspension



P1a Box with Euro hole

P2a Box with other type of suspension



P0b Bag without any type of suspension



P1b Bag with Euro hole



P1c Pouch with Euro hole



P2c Pouch with other type of suspension



P1d Bag with tab card and Euro hole



P1e Hanger with Euro hole

P2e Hanger with other type of suspension



P0f Shrink-wrapped without any type of suspension



P1f Shrink-wrapped with Euro hole



P0h Tube without any type of suspension

P1h Tube with Euro hole



P1k Cassette with Euro hole



P0n Sleeve without any type of suspension



P1p Watchbox with Euro hole



P2p Watchbox with other type of suspension

Combined plastic / cardboard packaging (**P**lastic and **C**ardboard)



PC1a Blister with Euro hole



PC1b Folding blister with Euro hole



PC1c Shrink-wrapped carton with Euro hole



PC1d Tight Pack with Euro hole

Metal packaging (**M**etal)

Unpacked product (**U**npacked)

Wood packaging (**W**ood)



M1a Cassette with Euro hole



M0b Aerosol without any type of suspension



U0 Without any type of suspension



W0a Case without any type of suspension

