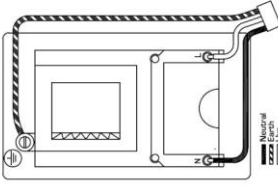
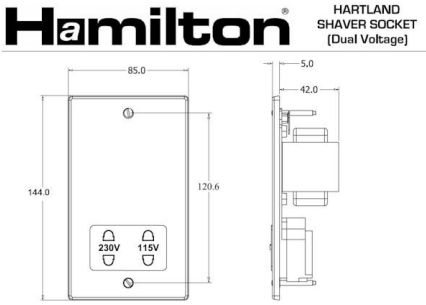

<p>Item Image</p> 
<p>Wiring</p> 
<p>Dimensions</p>  <p>Hamilton® HARTLAND SHAVER SOCKET (Dual Voltage)</p>

77 SHS W

Hartland Bright Chrome Shaver Socket Dual Voltage. Standard Insert will be White.

Primary Range	Hartland
Insert Type	Shaver Sockets
Plate Finish	Bright Chrome
Frame Finish	
Switch Colour	
Body & Switch Trim	White
Height	Double Vertically Mounted = 144mm
Width	Double Vertically Mounted = 85mm
Depth	Double Vertically Mounted = 5mm
Fixing Hole Centres	Box Fixing = 120.6mm Vertical Box Fixing = 120.6mm Vertical
Minimum Wall Box Depth	47mm
Wattage	
Switched Poles	none
Current Rating	20VA
Voltage	220/250V AC
Max load	200/250V input; 115/230V 20VA output
Contact Gap Minimum	n/a
Terminal Capacity 1	5 x 1mm ²
Terminal Capacity 2	4 x 1.5mm ²
Terminal Capacity 3	3 x 2.5mm ²
Terminal Capacity 4	2 x 4mm ² Multi-Strand
Terminal Capacity 5	1 x 6mm ²
Earth Terminal Capacity 1	9 x 1mm ²
Earth Terminal Capacity 2	6 x 1.5mm ²
Earth Terminal Capacity 3	4 x 2.5mm ²
Earth Terminal Capacity 4	2 x 4mm ² Multi-Strand
Earth Terminal Capacity 5	1 x 6mm ²
Product Class 1	Must be earthed
Ambient Operating Temperature	-5° to +40° C
Recommended Location	Indoor use only
Standard/Approval	BS EN 61558 - BS 4573
Patents and Trademarks	Trade Mark No. 2344778

All products listed conform to current British or European standards and the product information is correct at the time of going to press.	All accessories are manufactured under an accredited BS EN ISO 9001 : 2008 Quality System.	It is the policy of the company to continually improve products as part of our development programme. Therefore, we reserve the right to alter designs and dimensions without prior notice.
Illustrations and diagrams are reproduced within the limitations of reproductions and printing processes are not binding.	Due to manufacturing processes we cannot guarantee an exact colour match and shadings of certain finishes.	Correct as at August 2012 E&OE

R Hamilton & Co Ltd • Quarry Industrial Estate • Mere • Wiltshire • BA12 6LA • UK
 T: +44 (0)1747 860088 • F: +44 (0)1747 861032 • E: info@hamilton-litestat.com
 www.hamilton-litestat.com

Directors: R Hamilton • I Hamilton • RL Haines • CP Savory • AMH Hamilton (Secretary)
 Registered Office: Cedar House • Breckland • Linford Wood • Milton Keynes • MK14 6EX • Buckinghamshire
 Registered in London No. 941624 • VAT Registration No. 222 6607 84

