



Technical Data

SST Mechanical Staircase Timers



- Mechanical Staircase Timer Switch
- Countdown from 30sec. - 20min.
- Electronic Overload Protection
- DIN Rail Mounting (TS 35)
- External Push Switch Control
- Toggle Switch for Permanent Light

ORDERING INFORMATION

Part Number	Features
SST-5-1C	Daily Timer with 3 Day Battery Backup

DIMENSIONS (mm)

Part Number	Height	Width [w]	Depth	x
SST-5-1C	81.5	18.0	66.0	45.0

GENERAL INFORMATION

Enclosure Material	Self-Extinguishing Thermoplastic
Protection Class	Class II According to EN 60730-1
Ingress Protection	IP20
Approvals	CE
Mounting Type	DIN Rail (TS 35)

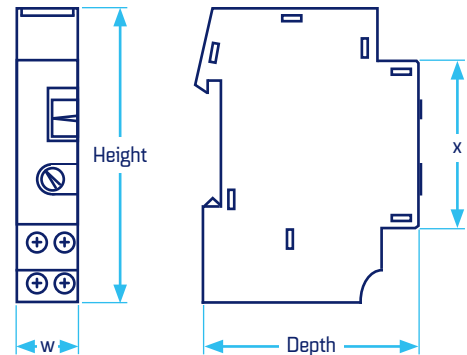

TECHNICAL SPECIFICATION

Part Number	SST-5-1C
Supply Voltage	220V AC, 50/60Hz
Switching Capacity (Resistive Load)	16A / 250V - at $\cos \phi=1$
Switching Capacity (Inductive Load)	10A / 250V - at $\cos \phi=0.6$
1/2-Way Conductors	Automatic
Countdown Range	30sec. - 20mins.
	0 - 20mins. (± 150 secs.)
	0 - 30secs. (± 3 secs.)
Power Consumption	4VA
Switching Output	Potential Free & Phase Independent
Glow Lamp Load	150mA max.
Ambient Operating Temperature	-10°C to + 50°C

WIRING DIAGRAM

With Neon Lamp

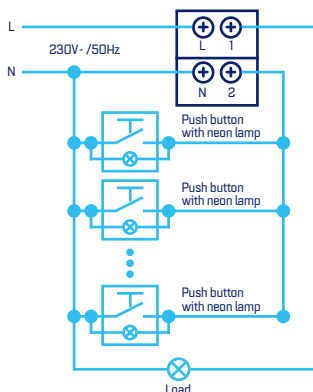

Without Neon Lamp

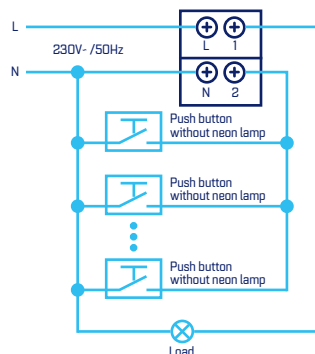

For more information, email sales@stag-electrical.com
www.stag-electrical.com