

Surface & Suspended Range

EDITION 6



QVIS

LED LIGHTING

QVIS

LED LIGHTING

Qvis Lighting has specialised in commercial and industrial LED lighting since 2014, whilst the Qvis brand itself has been established for over ten years, with track record success in many industries. From the outset, Qvis has signed up to the Lighting Industrial Association (LIA) and is actively part of their Quality Assurance program (LIAQA). Similarly, Qvis is part of the Philips enabled licensing community, the manufacturers association (EEF), ICEL emergency association, and an ISO 9001:2015 quality management firm.

Qvis products are fully tested by the LIA independent testing laboratories and have gained membership to the Carbon Trust and the Society of Light and Lighting. Qvis continues to win accolades within the industry, with recognition as an LED supplier with quick high quality bespoke product turnarounds and cutting-edge efficacy across the range. Using the latest LED technology advancements, the Qvis brand is now very much established as an affordable name without compromising on quality or performance.

ACCREDITATION



OUR SUPPLIERS

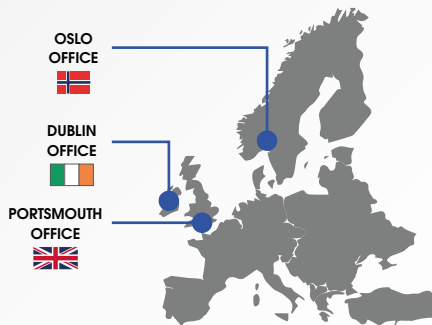

Contents

Linear

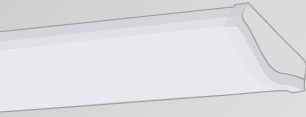

PROTEUS

Pages 2 to 3

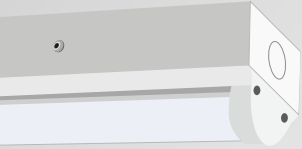

QLINE

Pages 4 to 5

Bulkhead

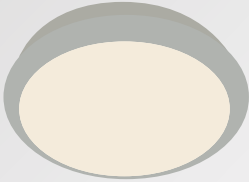

VEX BULKHEAD

Pages 6 to 7

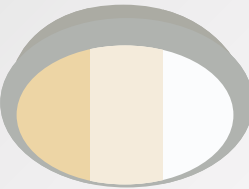

VEX TRI-COLOUR BULKHEAD

Pages 8 to 9

Architectural Luminaire



POLO

Pages 10 to 11

Proteus

Linear

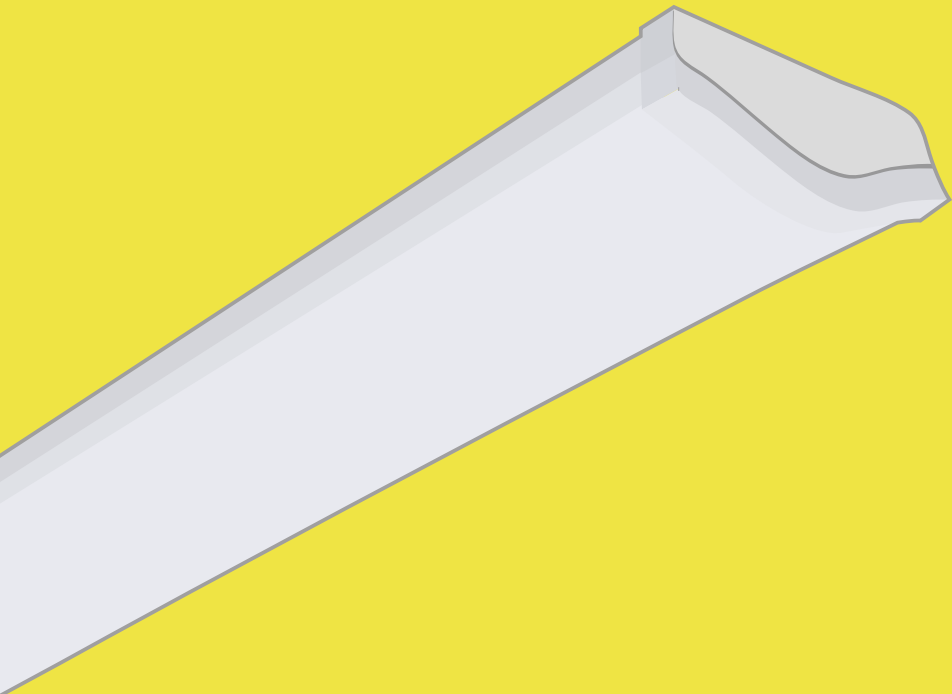

PTS/

35W POWER	50W POWER	65W POWER	65W POWER
4200 LUMENS	6000 LUMENS	7800 LUMENS	7800 LUMENS
/-35- 1500NW	/-50- 1500NW	/-65- 1500NW	/-65- 1800NW

CONTACT US
FOR DETAILS ON
EMERGENCY AND
DIMMABLE OPTIONS

EPISTAR **TRIDONIC**

LEDs inside Driver as standard





**BESA
Mounting Points**



**Screw Supported
End Caps**



**Classic
'Education'
Design**



**Polycarbonate
Opal Diffuser**

**TP(a) Fire
Rating**

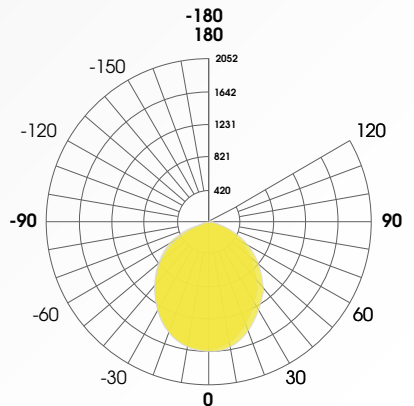
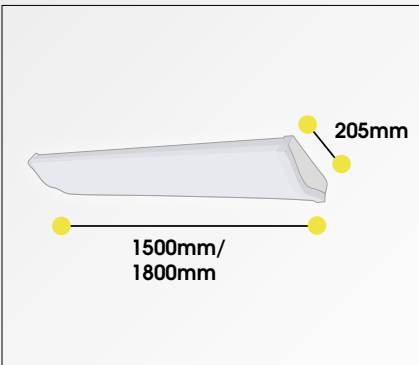

QLine

Linear

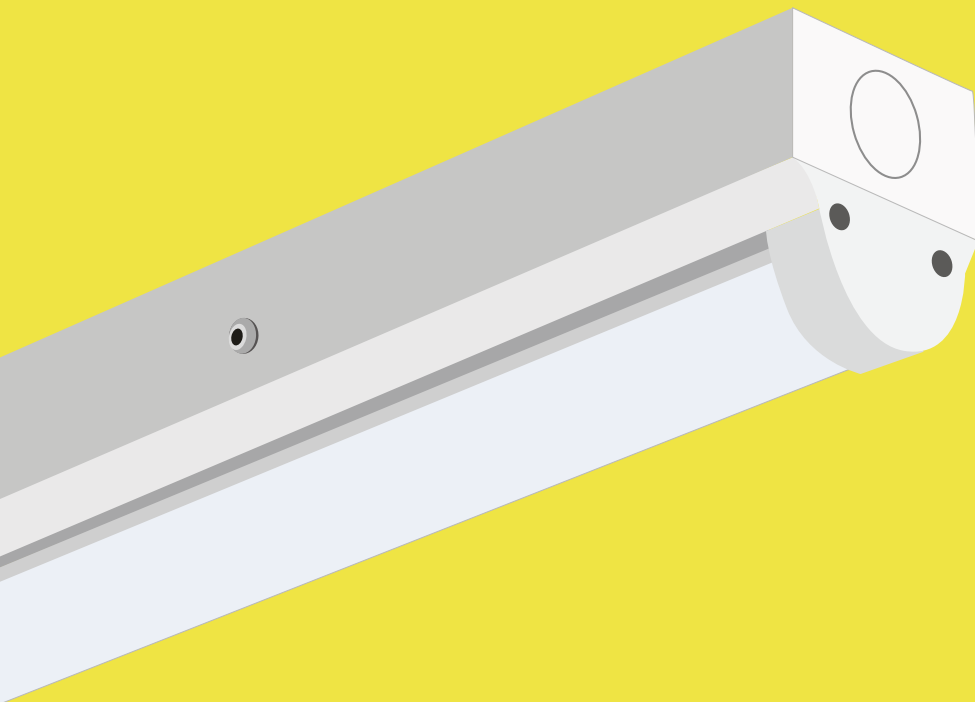

QLINE/

18W POWER	22W POWER	35W POWER	45W POWER	50W POWER
1800 LUMENS	2200 LUMENS	3850 LUMENS	4500 LUMENS	5500 LUMENS
/18- 1200NW	/22- 1500NW	/35- 1500NW	/45- 1500NW	/50- 1500NW

EPISTAR **TRIDONIC**
LEDs inside Driver as standard

CONTACT US
FOR DETAILS ON
EMERGENCY AND
DIMMABLE OPTIONS





Easy Push-Release
Diffuser Removal



Aluminium
Housing



Slim,
Compact Design



Polycarbonate
Opal Diffuser

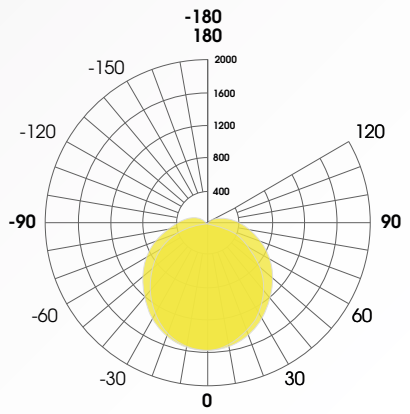
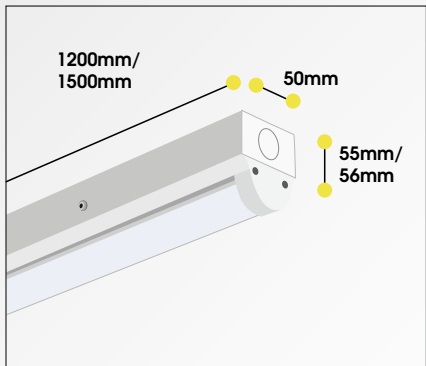
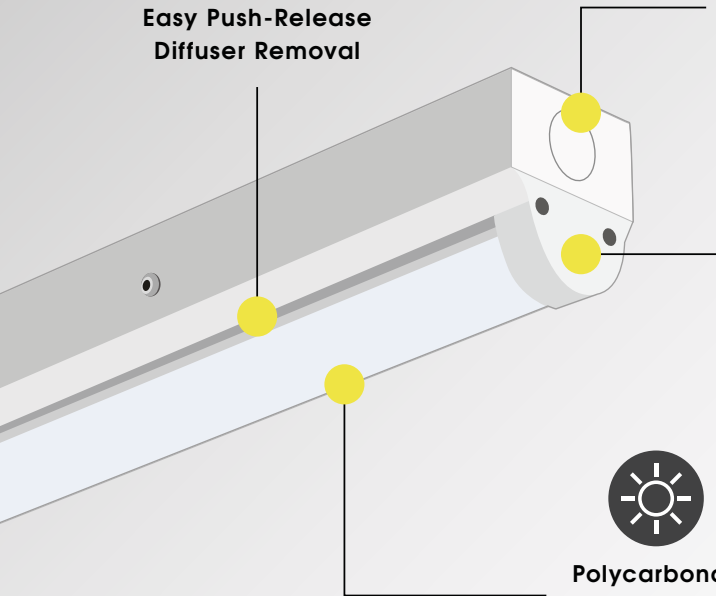

Vex

Surface Bulkhead

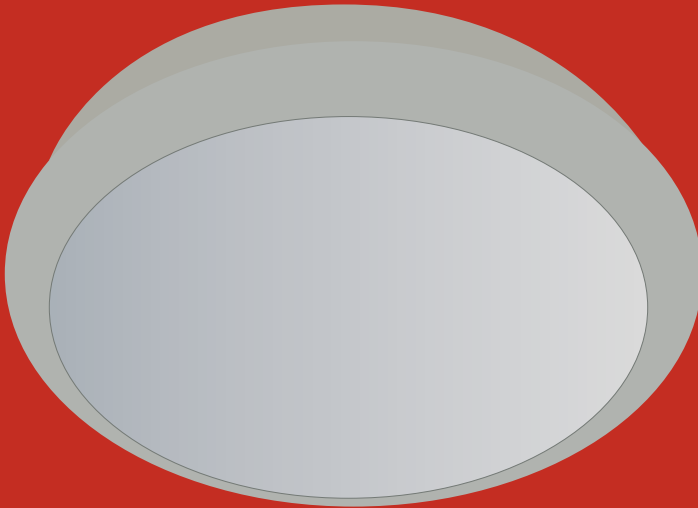

VEX/

SWITCHABLE

10W
POWER

15W
POWER

20W
POWER

25W
POWER

1050
LUMENS

1575
LUMENS

2100
LUMENS

2700
LUMENS

/-10/15-300
NW

/-20-360
NW

/-25-420
NW

EPISTAR **TRIDONIC**

LEDs inside Driver as standard

CONTACT US FOR
DETAILS ON EMERGENCY
AND DIMMABLE OPTIONS





Emergency & Microwave Options From Stock



Tab-covered Conduit Side Entry Points

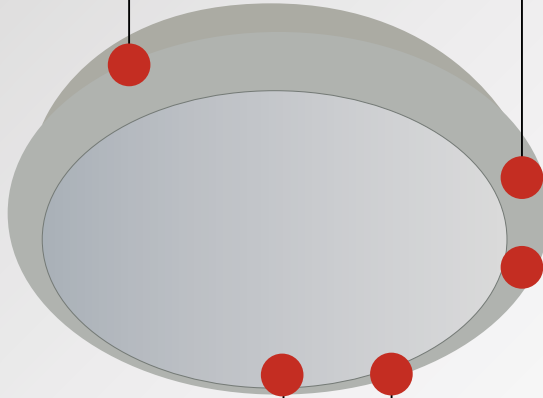

IP66 Rated as Standard



IK10 Rated as Standard



Polycarbonate Diffuser & Housing

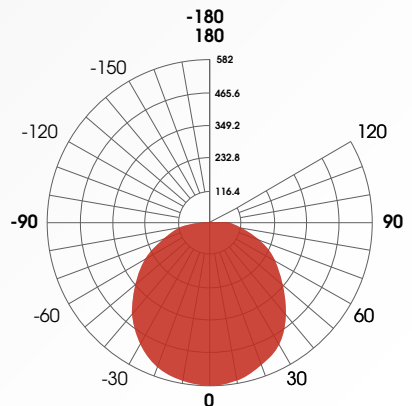
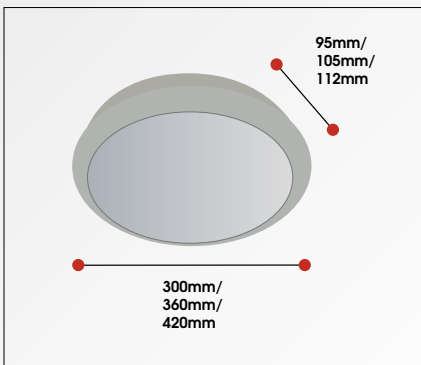

Vex

Tri-colour Bulkhead



Colour Switchable

3000K

4000K

6000K

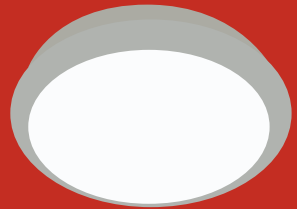
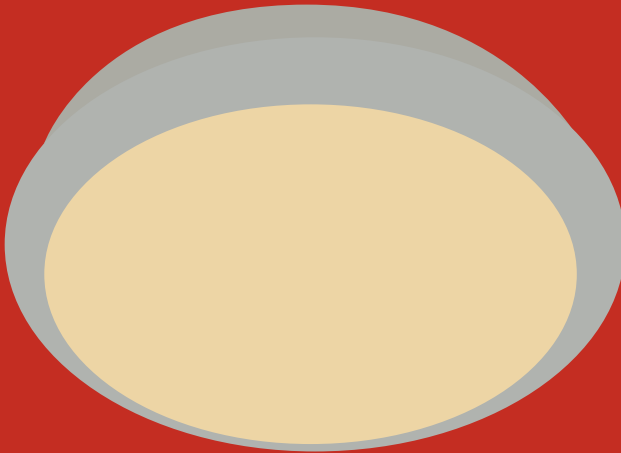

VEX-20-360TC

20W
POWER

2100
LUMENS

CONTACT US FOR DETAILS ON
EMERGENCY AND DIMMABLE
OPTIONS

EPISTAR **TRIDONIC**

LEDs inside Driver as standard



Polo

Architectural Luminaire

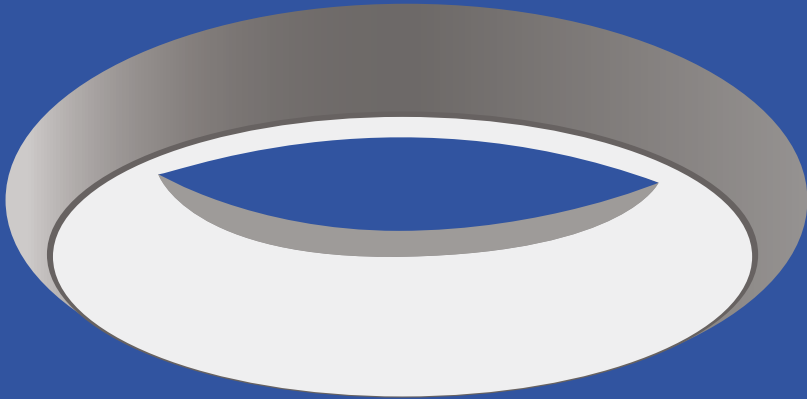

POLO-35-400-SNW

35W
POWER

3290
LUMENS

CONTACT US FOR DETAILS ON
EMERGENCY AND DIMMABLE
OPTIONS

EPISTAR **Q-DRIVE**

LEDs inside Driver as standard





Includes Surface Mount and 3-Wire Suspension Kit



Silver Powder Coating



Aluminium Curved Housing

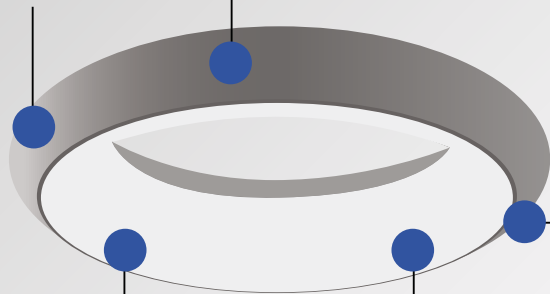

400mm Diameter for High Lumen Package



Polycarbonate Opal Diffuser

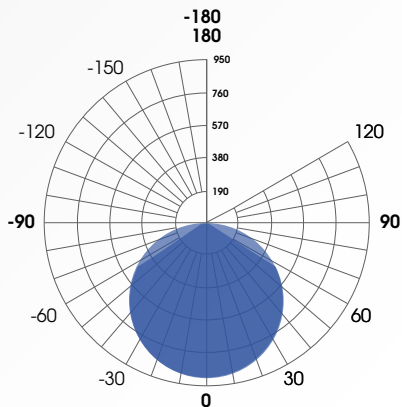
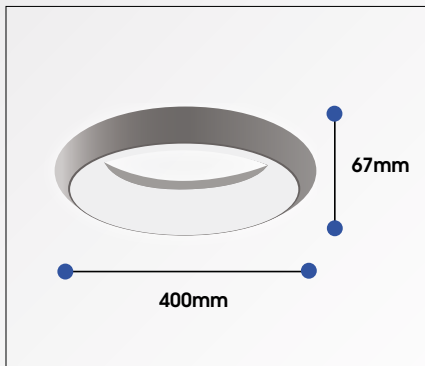

Ask about our

Emergency Catalogue

NEW FOR
OCTOBER 2019!

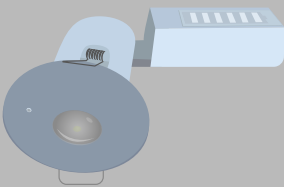

For more information, visit the Qvis LED website!



Find us at www.qvisled.com

CONTACT YOUR LOCAL REP

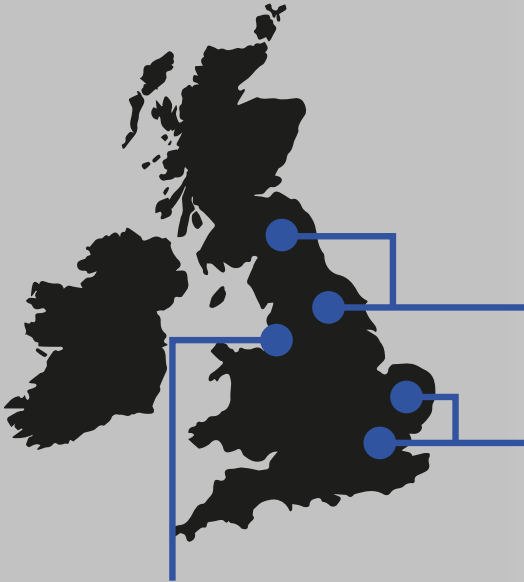

Nick (NORTH & MIDLANDS)

07741163721

Roxanne (E. ANGLIA & LONDON)

07741163917

Eva (MANCHESTER)

07741163914

QVIS
LED LIGHTING

Affordability Without Compromise

ADDRESS:

Qvis HQ, 36 New Lane, Havant, Hampshire, PO9 2JL

OPENING TIMES:

Monday to Friday - 8.00am to 5.30pm GMT

CONTACT US:

Call: +44 (0) 2393 870 050 Email: sales@qvislighting.com Website: www.qvisled.com