



AU-DSPLED 1-10 Volt 1 Gang 2 Way Rotary Dimmer

* Suitable for control of dimmable electronic transformers and tungsten lamps WITHOUT DE-RATING

AURORA
INTERNATIONAL LIGHTING CORPORATION



AURORA
INTERNATIONAL LIGHTING CORPORATION

I-10 VOLT DIMMER SWITCH

ROTARY CONTROL - PUSH ON / PUSH OFF FOR DIMMABLE LED DRIVERS AND BALLASTS

AURORA 1 - 10V DIMMER SWITCH - INSTALLATION INSTRUCTIONS

Aurora dimmer switches comply with the latest European Safety and EMC Regulations
Safety Compliance - EN 60669-2-1:2000
EMC Compliance - EN 50015

READ THESE INSTRUCTIONS CAREFULLY BEFORE INSTALLATION

PLEASE LEAVE A COPY WITH THE USER/MAINTENANCE ENGINEER FOR FUTURE REFERENCE

PRODUCT FEATURES

- Push on, push off, rotary dimming control switch.
- Suitable for use Aurora Dimmable LED Driver and 1 - 10V Dimmable Ballasts
- Integrated over-temperature protection fuse.
- Short-circuit protection.
- Module case ultrasonically sealed to reduce dimmer buzzing
- Smooth dimming operation from 0 - 100%
- One or two way switching

APPLICATIONS

- Aurora dimmer switches are suitable for the following applications:
- Dimming of Constant Current LED's when used in conjunction with the Aurora Dimmable LED Driver
- Dimmable Ballasts requiring a 1 - 10V control input

Please Note This Dimmer Switch CANNOT be used for:

- Mains Voltage GLS or Halogen lamps
- Electronic & Wire Wound low Voltage lighting transformers
- Fans
- Any electronic control gear that does not require a 1 - 10V control input.

INSTALLATION

READ THESE INSTRUCTIONS CAREFULLY. IF IN ANY DOUBT, CONSULT A QUALIFIED ELECTRICIAN

1. Install the mounting box in the required position.
2. A 3-core cable is required between the switch and the control gear (LED Driver or Ballast). Connect two wires from the 1-10V Dimmer terminal of the control gear to the + and - terminals of the dimmer switch. Connect a live feed to the common of the dimmer switch and connect from L1 to the Live input of the control gear. See diagram overleaf.
3. To connect the dimmer switch for 1 or 2-way switching, please refer to the diagram overleaf.
4. When stripping the cables for wiring ensure that no bare conductors can project from the terminals.
5. Dimmer switches with a metal front plate MUST be earthed using the Earth terminal or Earth fly lead on the front plate.
6. After connecting the wiring push the dimmer switch back towards the wall box ensuring the that the wiring is not trapped between the back of the dimmer module and the mounting box or the front plate and the mounting box, tighten the plate fixing screws provided. Do not over-tighten the fixing screws or you may distort or break the front plate.
7. When installation is complete switch on the mains supply and push the dimmer knob to operate. Adjust the rotary knob until the desired light level is reached.
Please note - DO NOT perform insulation resistance tests on a lighting circuit with a dimmer switch connected. An insulation resistance test may damage the electronic components in the dimmer beyond repair.

A slight buzzing noise may be heard from the dimmer switch in operation, this is perfectly normal.

WIRING CIRCUITS

Aurora rotary dimmer switches are suitable for 1 or 2-way lighting circuits.

The dimmer has a push-on, push-off switch action and a rotary action to dim the light.

Each 1 - 10V dimmer module has 5 screw terminals, L1, L2, C (common) and the 1 - 10 V connections marked + and -

1-Way Switching

In 1-way lighting circuits each light is controlled by 1 switch.

Connect the two wires either way round, to the C terminal and either L1 or L2. One of the L terminals is not used in 1-way switching.

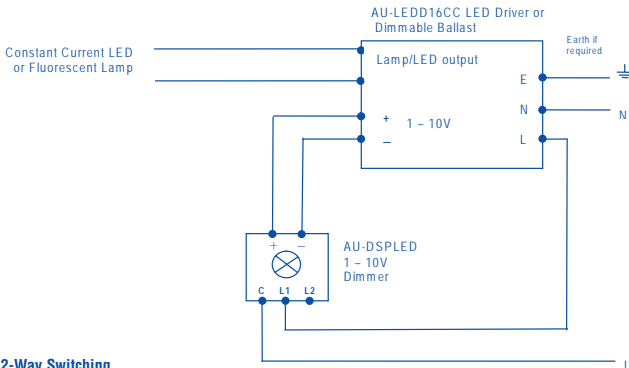

2-Way Switching

2-Way lighting circuits have two switches controlling the same lights from two different locations.

This arrangement is commonly used at the top and bottom of staircases or at the entry and exit doors to a room.

One standard plate switch is used with the dimmer switch for 2-way switching applications. See below for a typical 2-way circuit.

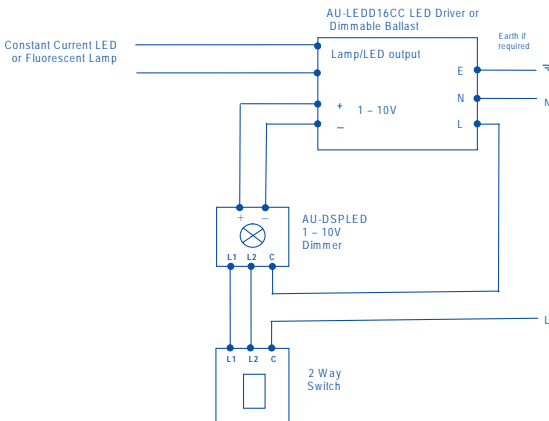

Environmental Protection (W.E.E.E.) – Aurora's WEEE Reg.No. WEE/BG0130YX



Waste Electrical & Electronic Equipment Regulations (WEEE) requires that any of our products showing this marking (left) must not be disposed of with other household or commercial waste. Aurora does not levy any WEEE disposal charges to its customers for affected WEEE related products. To prevent possible harm to the environment or human health from uncontrolled waste disposal, please separate any such product from other waste types and recycle it responsibly at your local facilities. Check with your Local Authority, Recycling Centre or retailer for recycling advice. If, when you purchased any Aurora product, your supplier included a WEEE disposal fee, you should then contact your supplier for advice on his takeback of the product for the correct disposal.

GUARANTEE

This product is guaranteed for a period of 1 year from the date of purchase. The guarantee is invalid in the case of improper use or installation, tampering, removal of the Q.C. date label, installation in an improper working environment or installation not in accordance with the current edition of the I.E.E. Wiring Regulations (BS 7671).

This product must be used with 1 - 10V Drivers or Dimmers and must not be overloaded beyond its rating.

Should this product fail during the guarantee period it will be replaced free of charge, subject to correct installation and return of the faulty unit. Aurora does not accept responsibility for any installation costs associated with replacement of this product. Your statutory rights are not affected. Aurora reserve the right to alter specifications without prior notice.

Aurora Ltd. Unit 16, Alban Park, Hatfield Road, St. Albans, Hertfordshire. AL4 0JJ