

Toughflood Asymmetric

Installation of LED Floodlights

JCC | a **LEVITON** company

WARNINGS AND CAUTIONS

- It is recommended that luminaires are installed by a qualified electrician to ensure the installation complies with the local current wiring regulations.
- Any broken or damaged parts should be replaced as soon as possible. JCC will not accept responsibility for claims arising from sub-standard installations.
- Do not install in areas that are exposed to continual running water or prone to flooding. Ensure that the mounting surface is both flat and stable.
- These products are designed for connection to a 220-240V~ 50/60Hz supply.
- It may be necessary to upgrade your MCBs to allow for increased inrush current.
- Terminal block not included. Installation may require advice from a qualified person.
- To avoid electric shock, serious injury or property damage, isolate power before installing, removing or servicing the product.
- Do not carry out insulation tests with the product connected to the circuit.

INSTALLATION

ENGLISH

Specifications Colour temp: 4000K Ra: 70

Total circuit wattage	Lumens	LpcW
80W	9200	115
100W	11400	114
150W	17000	113
200W	24000	120

Finish: Grey

220-240V~50/60Hz / Class I Ⓢ

Figure 1. Mains input

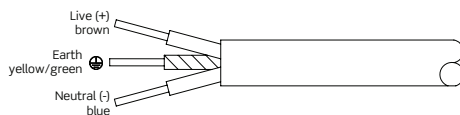

Wiring colours are for reference only

Terminal block must comply to EN 60998-2-1 or EN 60998-2-2

Terminal block specification:

Number of Ways	3
Mounting Type	Through Hole
Pitch	8mm
Current Rating	24A
Termination Method	Screw Down
Wire Size	2.5 mm ²
Material	Nylon
Voltage Rating	380 V
Maximum Operating Temp	+125°C
Contact Material	Brass
Contact Plating	Nickel

General Maintenance Requirements

JCC recommends that all exterior products, especially those with stainless steel components are cleaned with warm water and dried with a chamois leather or absorbent dry cloth. Weathering, environmental pollution and bird droppings should be cleaned off with a non-abrasive cleaner suitable for the material type. To preserve the finish of the product, clean every two to three months. After installation is complete, then bi-annually, grease or lubricate removable fixings, to help ensure maintenance is trouble free.

- Read instructions and check that you have all of the tools and accessories required to complete the installation correctly. Isolate power supply before starting the installation.

Installation procedure

- Prepare the mains input cable for termination. Note that this product is class I and as such must be fitted with an earth connection.
- Drill mounting holes and insert suitable wall plugs.
- Rotate fitting to access screw mounting points on the bracket and secure using suitable fixings.
- Terminate input wiring to the fitting as per Fig. 1 to the left using a suitable IP rated connector.
- Check seals, gaskets and the cable gland integrity before testing the luminaire.
- Turn on power supply and test for correct operation.

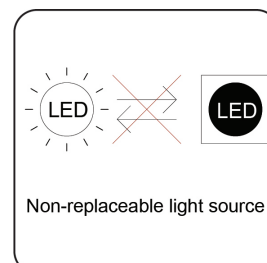

Non-replaceable light source

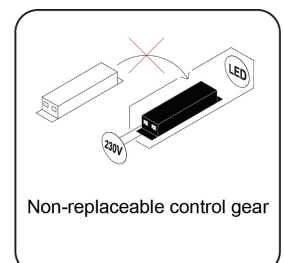

Non-replaceable control gear

Profile & Dimensions

80W/100W

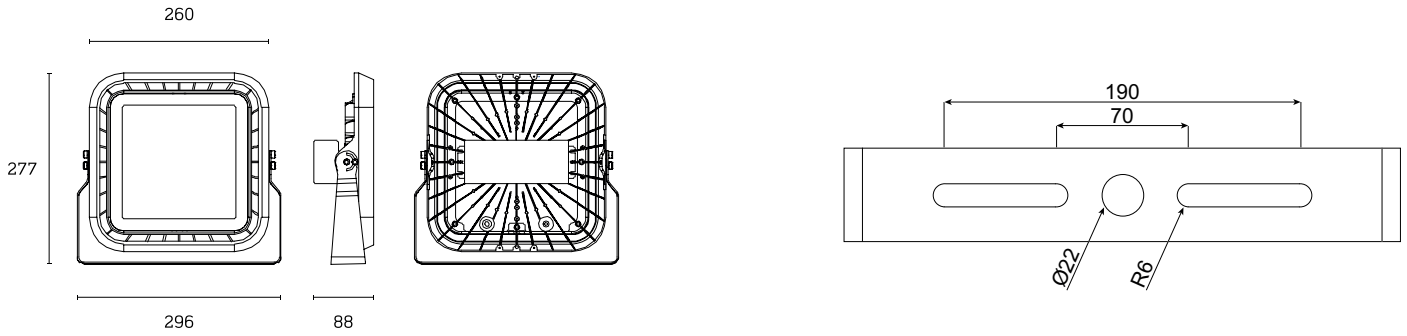

150W

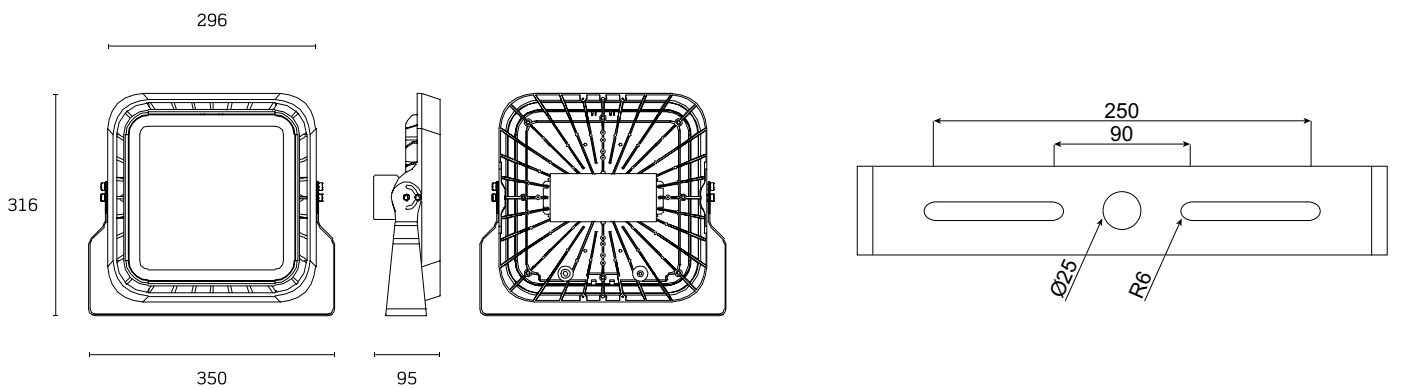

200W

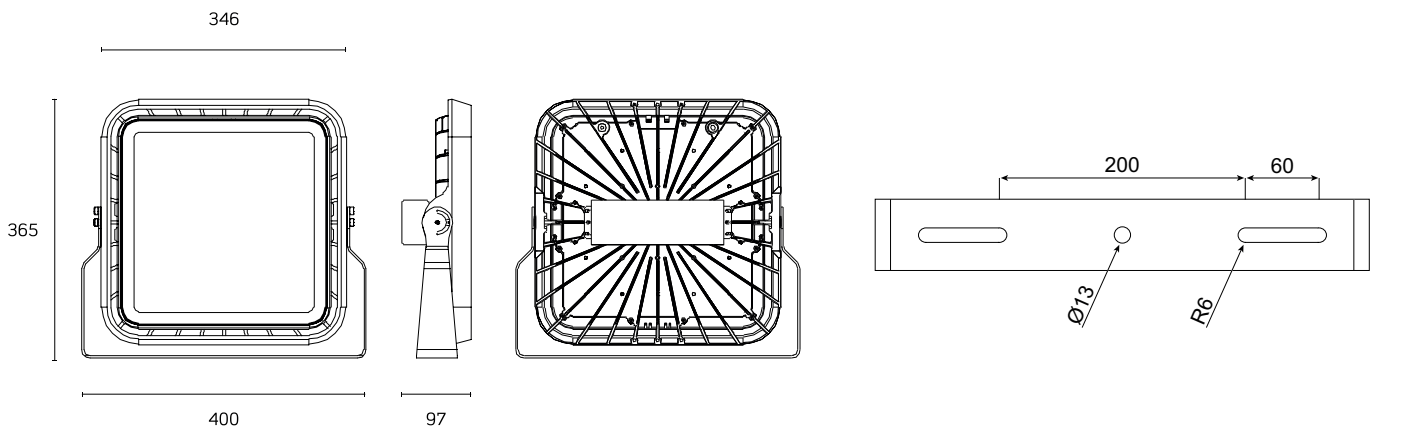

All dimensions in millimetres

You can help protect the environment. Please remember to respect the local regulations: hand in the non-working electrical equipment to an appropriate waste disposal centre. The packaging material is recyclable. Dispose of the packaging in an environmentally friendly manner and make it available for the recyclable material collection service.

Important warranty information

This product is supported by a 2-year standard warranty which will extend to 5-years if registered within the first year of purchase. Please register at jcc.co.uk/warranty (Terms and conditions apply).

The installer will be asked to provide the following information, which is detailed on a label attached to the luminaire's chassis:
Product Code/Date Code.