

Important Safety Notice

It is the responsibility of the person installing the electrical equipment to ensure that the installation meets the requirements of the IET wiring regulations and is therefore 'fit for purpose'. Factors such as correct selection of components, cable sizing, protective devices and Earth bonding are all critical and should be checked prior to full testing and power-up. Any other regulations applicable to the equipment being installed such as the Machinery Directive and current health and safety legislation must also be adhered to.

All connections (including factory made) must be checked for the correct tightness prior to commissioning of the electrical installation. All connections should be checked periodically to ensure correct tightness.

DO NOT USE POWER TOOLS ON THESE PRODUCTS

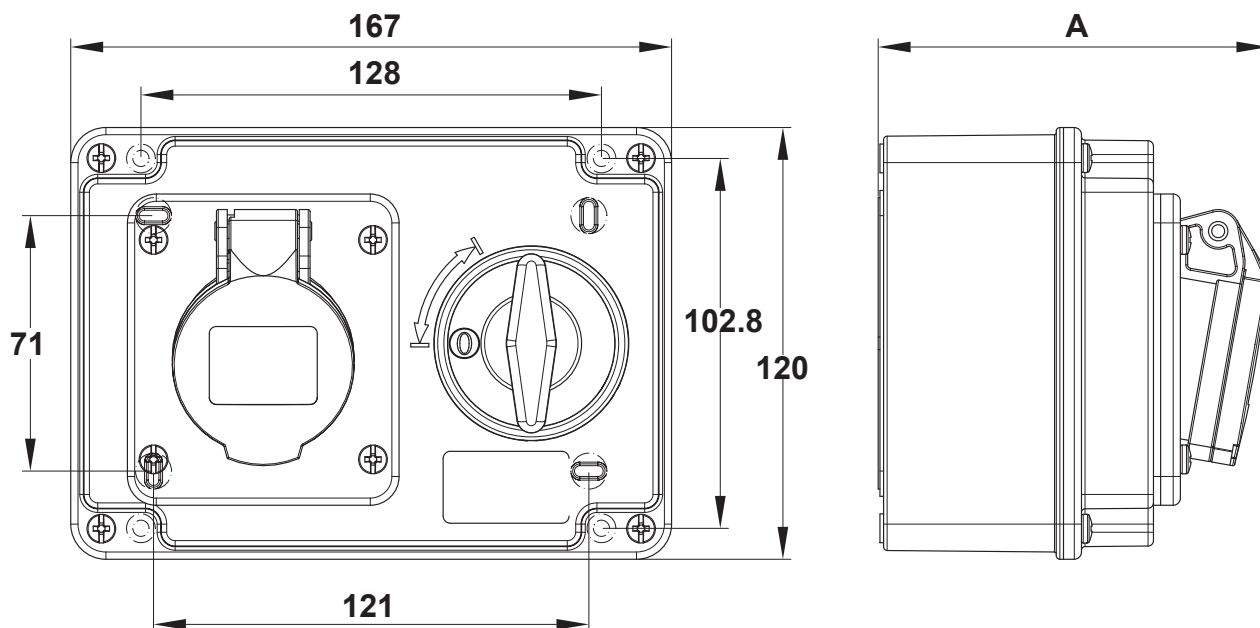

Part Number	Amps	Colour & Voltage	Poles	A (mm)	Cable Nominal Cross Section Area
SISH163F	16A	Yellow 110V ac	2P+E	108	1.5 - 4mm ²
SISH323F	32A	Yellow 110V ac	2P+E	118	2.5 - 10mm ²
SISH163P	16A	Blue 230V ac	2P+E	108	1.5 - 4mm ²
SISH323P	32A	Blue 230V ac	2P+E	118	2.5 - 10mm ²
SISH164N	16A	Red 400V ac	3P+E	111.5	1.5 - 4mm ²
SISH324N	32A	Red 400V ac	3P+E	118	2.5 - 10mm ²
SISH165N	16A	Red 400V ac	3P+N+E	112	1.5 - 4mm ²
SISH325N	32A	Red 400V ac	3P+N+E	120.5	2.5 - 10mm ²

Associated Product - IP44 Industrial Plugs



Part Number	Voltage	Amps	No. of Poles
IP163F	110V	16A	2P + E
IP323F	110V	32A	2P + E
IP163P	230V	16A	2P + E
IP323P	230V	32A	2P + E
IP164N	415V	16A	3P + E
IP324N	415V	32A	3P + E
IP165N	415V	16A	3P + N + E
IP325N	415V	32A	3P + N + E