



# Technical Data

## Co-axial Socket Outlet

### Brief product description:

The Brushed Stainless Steel range of screwed flat-plate is suitable for domestic and commercial applications.

### Features:

- Manufactured to BS 5733
- Co-axial socket minimum mounting box depth 25mm
- For further TV & Satellite outlet options see our Euro Module range

### Product Images



SBS60

### Technical Specifications

Standard(s)	BS 5733 where applicable
RoHS Directive	No
WEEE Directive	No
Mounting Box Depth(Min)	25mm
Fixing Centres	60.3mm
Size	87.4mm x 87.4mm x 27mm

### Weights & Dimensions

Cat No.	Description	Pack Quantity			Dimension (W x L x H) cm			Weight (g)			CMB (m <sup>3</sup> )
		Each	Inner Box	Outer Box	Product	Inner Box	Outer Box	Each	Inner Box	Outer Box	Outer Box
SBS60	1G Co-Axial Socket	1	10	100	3.3 x 9 x 9.2	20 x 18 x 9.8	41.5 x 52.5 x 19				

### Packaging Information

Cat No.	Description	Barcode			Cat No.	Description	Barcode		
		Individual	Inner Box	Outer Box			Individual	Inner Box	Outer Box
SBS60	1G Co-Axial Socket	5050765005937	/	/					

# Co-axial Socket Outlet

## Installation Information

### Safety Warning

Before use please read and carefully use in accordance with these safety wiring instructions.

To ensure a satisfactory operation these products should be installed by a competent person. If in doubt seek advice from a qualified engineer.

These products should not be installed into the same enclosure containing mains exceeding 50V. Avoid running the telecom cable within 50mm of mains electrical cable.

### Socket Types

**1. Non-Isolated** – Intend for use in installations with direct connection to the Aerial down-lead.

**2. Isolated** – This type of co-axial outlet provides a safety installation between the Aerial down-lead and the co-axial socket. These sockets are not suitable for use in systems where DC signals are passed through the socket. For example, where masthead/headend equipment is controlled by receiver/decoder equipment).

**3. TV/FM Diplex** – This diplexer unit separates the TV and FM band signals from systems where both signals are combined on a single aerial down-lead.

**Technical Helpline: 0845 194 7584**  
If in doubt consult a competent electrician.

### General Installation Instructions

- 1) If using the new product to replace an old one, note the cable connections and wire up new product in the same way as the old one, with Earthing as stated in these instructions.
- 2) Ensure the mounting box (metal or patress) for either flush or surface mounting is the appropriate size for the product.
- 3) Route the cable through the most suitable entry point of the mounting box. If a metal box is used, a protective cable grommet should be used.
- 4) Strip the cable to the dimensions shown in the diagram opposite. (Fig.1)
- 5) Connect the inner conductor to the square terminal block and securely clamp the screening braid under the clamp, ensuring that there are no loose conductor strands that may cause short circuits. To assist with the correct installation of this product please consult the appropriate wiring diagram.
- 6) When tightening the screening braid clamps ensure that the cable is firmly gripped and that the inner insulation is not squashed flat beyond a slight oval shape. Always tighten the terminal screws securely, but do not overtighten.
- 7) Carefully position the accessory into the wall box, ensuring that no wires are trapped between the plate and the wall. Do not overtighten the screws. (Fit screw covers + clip-on front-plate as appropriate)
- 8) Once work has been completed correctly, the product is now ready for use.

\* Note - If your installation uses a four lug metal mounting box, remove the top and bottom lugs or bend fully back.

It is essential the gasket is fitted between product and wall, to reduce possibility of discolouration of front plate edges due to natural moisture in some wall finishes.

To keep the finish of this product, wipe over with soft cloth periodically.

All Decorative products MUST have an earth connection between the front-plate and back box

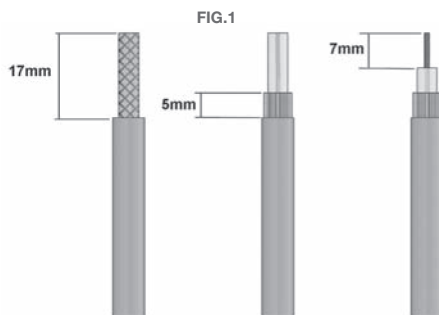

**Step 1:** Remove 17mm of outer sheath

**Step 2:** Twist screening braid back onto itself until 5mm long

**Step 3:** Remove 7mm of inner insulating sheath

### Connection Diagram

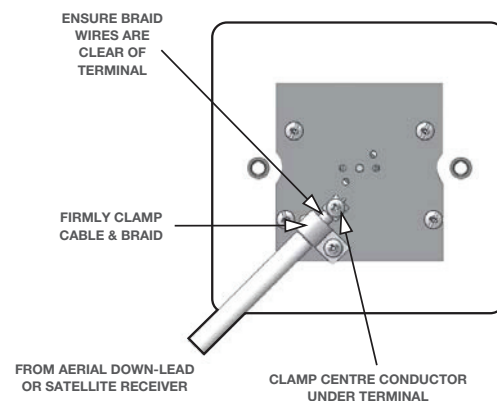

To maintain the high quality appearance of decorative finish switches and sockets, BG Electricals recommend the use of a soft cloth periodically to clean the front face. When installing a decorative product please ensure that the wall is decorated, finished and free of moisture prior to installation. Please note that it can take several weeks for the chemicals in paint or wallpaper paste to become inert. Before this time there is a danger that they will react with the product if it has a metal faceplate.

BG recommends avoiding using, but not restricted to, the substances from becoming in contact with the decorative metal front-plates when cleaning or decorating;

- Adhesive tape, including masking tape
- Solvents
- White spirit
- Multi surface cleaners
- Industrial multipurpose cleaning wipes
- Wet wipes

Using these items like those listed above may cause a degrading effect to the front-plates lacquer/plated finish, although the function will remain unaffected.