

# RadioLINK RELAY BASE

## Instruction Manual

Contains vital information on the product's operation and installation. Read and retain carefully. If you are just installing this product **the manual MUST be given to the householder.**

### 1. Introduction

The Ei428 RadioLINK Relay Module is a device that switches a relay upon receipt of an alarm signal from a suitable Ei Alarm. The electrically isolated contacts can be used for many applications such as signalling, turning on lights, etc. The Ei428 is designed to operate with Ei RF devices.

The Ei428 RadioLINK Relay Module is powered by the 230VAC mains and has rechargeable back-up cells. As supplied the relay operates continuously (i.e. it switches when one of the Alarms detects fire and switches back when the alarm condition is finished).

### 2. Installation

**WARNING:** Mains powered Ei428 RadioLINK Relay modules should be installed by a qualified electrician in accordance with the Regulations for Electrical Installations published by the Institution of Electrical Engineers (UK) (i.e. BS7671) Failure to install the unit correctly may expose the user to shock or fire hazards. This unit is not waterproof and must not be exposed to dripping or splashing. **The Ei428 must only be installed in a building installation where an appropriate disconnect device has been fitted (i.e. all-pole mains switch).**

1. Choose a suitable mounting position near the mains supply and the device to be connected to the relay. Keep it away from metal surfaces or large metal objects (e.g. water cylinder, fuse boards) which can reduce the RF signal range.
2. Disconnect the AC mains supply from the circuit that is going to be used.
3. Where the incoming wiring is on the surface of the wall/ceiling, the appropriately sized trunking / conduit must be chosen to mate with the unit. Use a sharp knife to remove the material from the knockout, making sure that there is no gap when mated with trunking/conduit. There is one suitable surface cabling knockout (the other two surface entries are not recommended as the wiring will reduce the antenna signal). There is one rear entry knockout. See figure 1b.
4. Screw the Ei428 module to the wall after first removing the required knockout and bringing the house wires through it (see figure 1b).

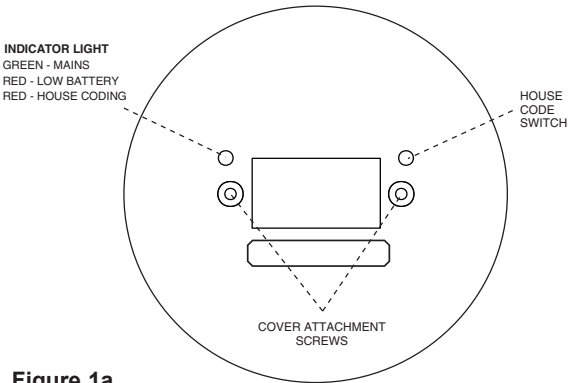
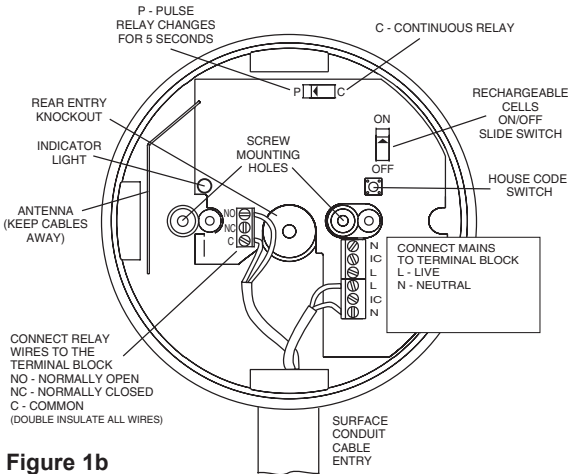

**Figure 1a**

5. Connect the house wires (L-Live to wires coloured brown, red or marked L, N-Neutral to wires coloured blue, black or marked N) to the terminal block as shown in figure 1b.

NB: The unit must not be earthed so do not connect a green / yellow or copper earth wire to any terminal.

6. Connect the wires to the required relay contacts for controlling the auxiliary device. (The contacts are isolated and are rated at 250VAC, 5 amps resistive).



**Figure 1b**

If momentary relay operation is required, carefully and gently slide the yellow switch to the “P” position with a small screwdriver (see figure 1b). This is commonly used with warden call systems where only momentary short circuit signalling is required. This must be done before the mains power is connected or the rechargeable cells are activated.

With the switch in the “C” position, the alarm signal will switch the latching relay until it receives a cancel signal.

7. Connect the rechargeable cells by carefully and gently sliding the switch to the “ON” position (see figure 1b). This switch must be in the ‘on’ position to ensure correct operation.

8. Fit and screw the cover to the module pillars using the two screws supplied.
9. Connect the mains power to the Ei428 module. Check the green light is on. If the green light changes to red every 10 seconds then switch off the mains power, remove the cover and check that the battery slide switch is in the "ON" position (see figure 1b). Replace the cover and turn the mains power back on. If there is still a problem the rechargeable cells may be depleted, leave the unit on mains power for 2 hours to charge and test again.
10. Press and hold the House Code switch through the hole in the cover using a small screwdriver, see figure 1a, until the green light changes to red. Release the switch and the light will flash red quickly, a few times. The red light will then flash every 5 seconds.
11. House code all other RF Alarms and devices in the system. Consult the instruction manuals on how to house code the Alarms and devices. It is essential that each individual Alarm/device is put into House Code mode in its final location.
12. Check the number of flashes on the Ei428 and on every other device. They should correspond to the total number of devices in your system. A system with 3 Alarms and 1 Ei428 will result in 4 flashes. It may take up to 10 minutes before all 4 flashes are seen.

The flash pattern will repeat every 5 to 10 seconds while the Ei428 remains in house code mode. If it fails to flash the correct number of times, then consult the "Troubleshooting" section of this instruction manual. To complete the commissioning, the RF system must exit House Code mode.
13. The Ei428 will automatically exit House code mode after 30 minutes. Other devices may exit after only 15 minutes. Once coded, the system will not communicate with any other RF Alarms and devices outside of the house coded group.

To manually exit House Code mode, press the House Code button again on the Ei428 until the RF indicator lights up red, then release. This will send a signal to all the other RF Alarms and devices to exit House Code mode.

After a short period, the red light will turn off and the system will return to standby mode. Depending on the number of RF Alarms and devices in the system this period could vary from 5 to 20 seconds.

Note: Not all devices are able to receive the Exit House Code mode signal from another device. If some devices continue to flash amber / red, please consult their instruction manual to manually exit house code mode.

Check that the RF indicators have stopped flashing on all devices.
14. To check the system, press the Test button for up to 60 seconds on any house coded Alarm. After a few seconds

all Alarms should sound. Ensure that the device connected to the relay contacts operates. After 60 seconds release the test button – check the device switches off. (If the continuous/pulse slide switch is in the pulse position, check the relay just switches on for 5 seconds and then switches off). All RF devices in the house code system should be checked similarly.

### **3. Troubleshooting RadioLINK**

If, when checking the radio link interconnection, some of the Ei428 RadioLINK Relays do not respond to the button test, then:

- (i) Ensure you have held the smoke/heat alarm test button down until the RF light comes on (this could take up to 40 seconds).
- (ii) Re-locate/rotate the units. There are a number of reasons why the radio link signals may not reach all the RadioLINK Relays in your system (see section on “Limitations of Radio Frequency Signals”). Try rotating the unit or re-locating the units (e.g. move them away from metal surfaces or wiring) as this can significantly improve signal reception.

Rotating and/or relocating the units may move them out of the range of existing units even though they may have already been house coded correctly in the system. It is important therefore to check that all detectors/relays are communicating in their final installed positions. If units are rotated and/or resited, we recommend that all units are returned to the factory settings (press and hold the house code switch on for about 6 seconds until the relevant light comes on and then flashes slowly). Then house code all units again in their final positions as indicated above. The RadioLINK interconnection should then be re-checked again.

### **4. Checking & Maintaining Your Smoke Alarm System**

We recommend a weekly check is made of your alarm system. When checking the system also check the Ei428 as follows:

- (i) After 10 years (see date on the side of the RadioLINK Relay Base) the Ei428 Relay module must be replaced.
- (ii) Check that the green mains power indicator is on (if this is off, check circuit breaker fuse, wiring etc.). When the mains is restored the green light will come on solid.
- (iii) The light flashing red every 10 seconds indicates a battery problem. Check that the slide switch is in the “ON” position (See fig 1b) and leave the battery to recharge for 2 hours before checking again. If the unit continues to flash red every 10 seconds then the unit is defective and must be replaced, see “Getting your Relay Base Serviced” section.
- (iv) Check the relay switches and that the associated device operates when the system is in alarm (e.g. due to a smoke alarm test button being pressed).

## 5. Getting your Relay Base Serviced

If your RadioLink Relay fails to work after you have carefully read all the instructions, checked that the unit has been installed correctly, and is receiving AC power (green light on) contact Customer Assistance at the nearest address given at the end of this leaflet. If it needs to be returned for repair or replacement, open cover and turn off rechargeable cells with slide switch (see fig 1b). Put the RadioLink Relay in a padded box and send it to "Customer Assistance and Information" at the nearest address given on the unit or in this leaflet. State the nature of the fault, where the RadioLink Base was purchased and date of purchase.

## 6. Five Year Guarantee

Ei Electronics guarantees this Ei428 RadioLink Relay for 5 years from date of purchase against any defects that are due to faulty materials or workmanship. These guarantees only apply to normal conditions of use and service, and do not include damage resulting from accident, neglect, misuse, unauthorised dismantling, or contamination howsoever caused. These guarantees exclude incidental and consequential damage. If the Ei428 RadioLink Relay should become defective within the guarantee period, it must be returned to where it was purchased or alternatively to Ei Electronics, carefully packaged, with the problem clearly stated (see section 5 "Getting your Relay Base Serviced") along with proof of the date of purchase.

We shall at our discretion repair or replace the faulty unit.

## 7. Technical Specification

**Mains:** 230 VAC, 40mA, 50HZ, 0.8W.

**Mains Indicator:** Green LED lights continuously (apart from when it switches momentarily to red as outlined below).

**Battery Back-Up:** Rechargeable Built-In Lithium Cells. (operates for up to 2 months in standby)

**Approvals:** Complies with EMC, Electrical Safety and Radio Regulations – including requirements of the Radio Equipment Directive 2014/53/EU.

**Humidity Range:** 15% to 95% RH (non-condensing).

**Radio Frequency:** 868.499 MHz (Regulated 1% duty cycle band).

**RF Power:** +5dBm.

**Range:** 150 meters (minimum) in free space.

### RF RECEPTION

**Alarm Signal Reception:** Switches latching relay (with switch in continuous mode position 'C') until it receives an alarm cancel signal. It switches the relay for 5 seconds with the switch in pulse mode position 'P'.

**Low Battery Indication:** Red light flashes every 10 seconds. (The green light switches off when the red is on).

**Size of System:** The maximum number of RF Alarms should not exceed 12. In addition, a further 12 units consisting of a

combination of RadioLINK relays (i.e. Ei428 units), remote controls and manual call points, can also be used. Contact the Technical Services Department at one of the addresses below for advice on systems requiring more than this.

**Communication:** All units will communicate with other uncoded devices (e.g. Smoke Alarms) as shipped. After a unit has been house coded it will only communicate with other units house coded at the same time. House coding is essential to prevent false alarms from neighbouring systems.

**Duration of House Code Mode:** 30 minutes.

## 8. Limitations of Radio Communications

Ei Electronics radio communication systems are very reliable and are tested to high standards. However, due to their low transmitting power and limited range (required by regulatory bodies) there are some limitations to be considered.

- (i) Radio equipment, such as the Ei428 RadioLink Relay, should be tested regularly at least weekly. This is to determine whether there are sources of interference preventing communication. The radio paths may be disrupted by moving furniture or renovations, and so regular testing protects against these and other faults.
- (ii) Receivers may be blocked by radio signals occurring on or near their operating frequencies, regardless of the house coding.

This equipment generates, uses and can radiate radio frequency energy and, if not installed and used in accordance with the instructions, may cause harmful interference to radio and television reception.

However, there is no guarantee that interference will not occur in a particular installation. If this device does cause such interference, which can be verified by turning the device on and off (remove the mains supply and turn off back up power supply), the user is encouraged to eliminate the interference by one or more of the following measures:

- (i) Re-orientate or re-locate the unit.
- (ii) Increase the distance between the Ei428 and the device being affected.
- (iii) Connect the device being affected to a mains outlet on a circuit different from the one that supplies the Ei428.
- (iv) Consult the supplier or an experienced radio/television technician.

The crossed out wheelie bin symbol that is on your product indicates that this product should not be disposed of via the normal household waste stream. Proper disposal will prevent possible harm to the environment or to human health. When disposing of this product please separate it from other waste streams to ensure that it can be recycled in an environmentally sound manner. For more details on collection and proper disposal, please contact your local government office or the retailer where you purchased this product.



Hereby, Ei Electronics declares that this Ei428 RadioLINK Relay Base is in compliance with the essential requirements and other relevant provisions of Directive 2014/53/EU. The Declaration of Conformity may be consulted at [www.eielectronics.com/compliance](http://www.eielectronics.com/compliance)

**Aico Ltd,**

Mile End Business Park,  
Maesbury Road, Oswestry,  
Shropshire SY10 8NR, U.K.

Tel: 01691 664100

[www.aico.co.uk](http://www.aico.co.uk)

**Ei Electronics,**

Shannon Industrial Estate,  
Shannon, Co. Clare, Ireland.

Telephone: +353 61 471277

[www.eielectronics.com](http://www.eielectronics.com)