

TIMEGUARD®

3000W Multi PIR Light Controller

Model: MLB3000 – Black

Model: MLW3000 – White



Installation & Operating Instructions

1. General Information

These instructions should be read carefully and retained for further reference and maintenance.

2. Safety

- Before installation or maintenance, ensure the mains supply to the PIR sensor is switched off and the circuit supply fuses are removed or the circuit breaker turned off.
- It is recommended that a qualified electrician is consulted or used for the installation of this PIR sensor and install in accordance with the current IEE wiring and Building Regulations.
- Check that the total load on the circuit including when this PIR sensor is fitted does not exceed the rating of the circuit cable, fuse or circuit breaker.

3. Technical Specifications

- 230V AC 50 Hz
- This PIR is of Class II Construction and must not be earthed
- Motion Detection Range: Up to 12 metres at a 2.5m mounting height
- Detection Angle: 200°
- Maximum Switching Load: 3000W Halogen Lighting
500W Fluorescent Lighting
140W LED Lighting
150W Discharge Lighting (SON, HQI)
- Time ON Adjustment: 5 seconds to 18 minutes
- Dusk Level Adjustment: Day & Night or Night time only operation
- IP55 Rated suitable for restricted external applications
- CE Approved
- Manual Override
- Multiple PIR Sensor Switching: A maximum of 8 MLB-W3000 PIR sensors can be wired in parallel, to enable any detector to turn ON all the lights connected (The total load must not exceed the lamp rating of a single MLB3000 or MLW3000 unit).

4. Selecting a Location

- The motion detector has number of detection zones, at various vertical and horizontal angles as shown (see diagram "A").
- The best all-round coverage is achieved with the unit mounted at the optimum height of 2.5 metres.
- Careful positioning of the sensor will be required to ensure optimum performance (see diagram "A" & "B" detailing detection range and direction).
- The sensor is more sensitive to movement ACROSS its field of vision than to movement directly TOWARDS (see diagram "B"). Therefore position the unit so that the sensor looks ACROSS the likely approach path.
- Avoid positioning the sensor where there are any sources of heat in the detection area (extractor fans, tumble dryer exhausts etc.) including opposite any other light sources such as other security lights.
- Reflective surfaces (i.e. pools of water or white painted walls) may cause false activation under extreme conditions.

2

Diagram A

TOP VIEW

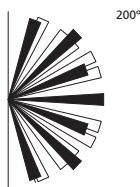

SIDE VIEW



Diagram B



←
Less
sensitive

↑
More
sensitive

Diagram C

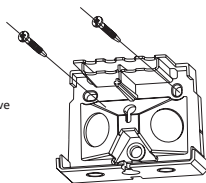

Diagram D

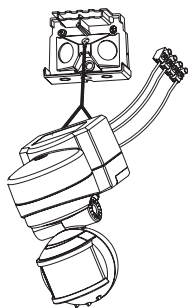

Diagram E

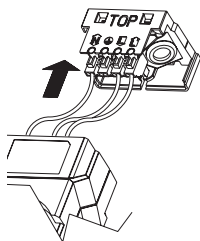

Diagram F

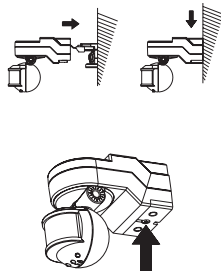

Diagram G

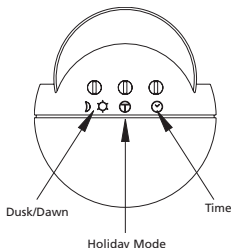
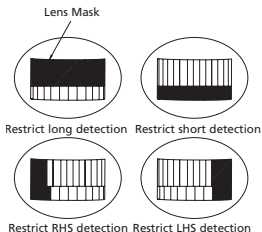

Diagram H



3

5. Installation

- Ensure the mains supply is switched off and the circuit supply fuses are removed or the circuit breaker turned off.
- An isolating switch should be installed to enable the power to be switched ON & OFF for maintenance purposes and to activate the manual/auto override function.
- Remove the wall plate by unscrewing the retaining screw (See diagram "F") and with a screwdriver gently push down and ease out the wall plate.
- Mark the position of the fitting holes using the wall plate as a template. Drill out the mounting holes taking care to avoid any joists, electrical cables or water/gas pipes that may be hidden beneath the surface. Insert the rawl plugs into the holes.

- Pass the 230V 50Hz mains supply and load cables through the cable entry points on the wall plate, ensuring the grommet(s) is used to maintain the IP rating of the PIR sensor.
- Fix the wall plate to the wall using the correct screws for the rawl plugs installed.
- This unit is supplied with a hanging attachment (tether) to aid installation. If it is not required, simply remove from the unit and discard.
- Place the round end of the tether into the keyhole shape location hole on the wall plate.
- Ensure the tether is securely fixed into the slot before releasing the weight of the unit.
- The unit can now be suspended below the wall plate (See diagram "D").
- Terminate the cables into the terminal block ensuring correct polarity is observed and that all bare conductors are sleeved (See section 6. Connection Diagram).
- Ensure the connections are secure.
- Place terminal block onto its securing pillar on the wall plate (See diagram "E").
- Remove and discard the tether.
- Fit control to wall bracket and secure by fixing screw (See diagram "F").

6. Connection Diagram

- Connect cables to the terminal block as follows;

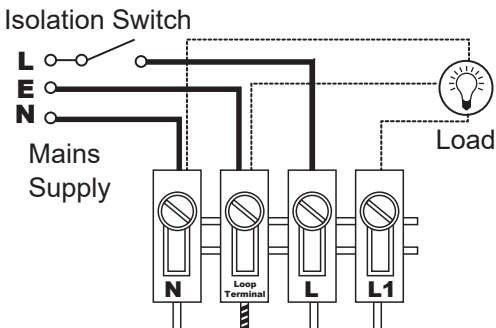

Mains Supply

Live (Brown or Red) to L
 Neutral (Blue or Black) to N
 A 'Loop Terminal' is provided
 should a 3 core cable be used,
 which is marked .

Load

Switch Live (Brown or Red) to L1
 Neutral (Blue or Black) to N
 A 'Loop Terminal' is provided
 should a 3 core cable be used,
 which is marked .

7. Operation and Testing

Walk Test Procedure

- The adjustment knobs located beneath the sensor head (see diagram "G") are factory set to "Walk Test Mode" i.e. LUX set to the 'Sun' symbol and the Time set to the minimum.
- Turn the power to the unit ON. The lamp will illuminate for approximately 30 seconds. This indicates the unit is wired correctly and the unit is in Test Mode.
- Adjust the sensor head to the desired direction for best coverage (See diagram "B").

Test Mode – Three LED's Visible

- The lamp will now illuminate for approximately 2 seconds every time movement is detected.
- Walk across the detection area approximately 5 metres from the unit. Each time you are detected the lamp will illuminate. Now stand still until the lamp extinguishes (this should take approx. 2 seconds)
- Start moving again, when you are detected again the lamp will illuminate.
- Repeat the above, walking at various angles and distances to the unit. This will help you to establish the detection pattern.
- If the detection area is too small for your requirements, try angling the sensor head up.
- Angling the head downwards will reduce the detection area should a smaller range be required.

Setting Up For Automatic Operation – 3 scrolling LED's Visible

- After walk tests are complete, simply cease movement within the detection area for approximately 60 seconds the unit will switch into Automatic Mode, this is indicated by the illumination of three scrolling LED's in the top transparent area of the sensor head. These LED's will scroll from left to right during daylight and darkness.
- The TIME setting controls how long the unit remains illuminated following activation, and after all motion ceases (See diagram "G". the time adjustment knob is indicated by the 'Clock' symbol).
- The minimum time (fully anti-clockwise) is approx. 5 seconds, whilst the maximum time (fully clockwise) is approx. 18 minutes. Set the control to the desired setting between these limits.
- The DUSK control determines the level of darkness required for the unit to start operating. The setting is best achieved by the procedure below (See diagram "G". the Dusk adjustment knob is indicated by the 'Moon' and 'Sun' symbols);
 1. Set the DUSK control knob fully anti clockwise.
 2. When the ambient light level reaches the level of darkness at which you wish the lamp to become operative (i.e. at dusk) SLOWLY rotate the control in a clockwise direction until a point is reached where the lamp illuminates.
 3. Leave the control set at this point.
 - At this position the unit should become operative at approximately the same level of darkness each evening.
 - Observe the operation of the unit. If the unit is starting to operate too early (i.e. when it is quite light) adjust the control slightly anti-clockwise. If the unit starts to operate too late (i.e. when it is very dark). Adjust the control slightly clockwise.
 - Continue to adjust until the unit operates as desired.
 - The LED's will scroll from left to right, day and night; indicating the unit is in Automatic Mode. The LED's will extinguish when the PIR activates the light for as long as the lamp is illuminated.

Masking the Sensor Lens

- To restrict the sensor coverage, preventing detection in unwanted areas, mask the sensor lens using the masks provided in the accessory pack (see diagram H).
- The top section of the lens covers long range detection, the bottom covers short range. Similarly the left and right lens sections cover the left and right detection areas respectively.

Manual Override Mode – Single LED Illuminated

The light can be switched on for longer time periods by use of the Manual Override Mode. This can be activated at night by using the internal wall switch or circuit breaker.

- Switch the internal wall switch/circuit breaker twice (OFF/ON, OFF/ON) within 2 seconds.
- The unit will now illuminate continuously for the user defined time, between 1 – 8 hours, or until the unit is switched back into auto mode.
- The ON time can be set by rotating the centre adjustment knob as required (see diagram G). This time adjustment is factory set to 1 hour (Fully anti-clockwise is 1 hour, fully clockwise is 8 hours).

Note: If the light is still ON at dawn, before the set time expires, it will automatically switch OFF.

- The Manual Override Mode can be setup in the day time or at night time.
- In the day time, the Manual Override mode is indicated by the permanent illumination of a single red LED in the top of the sensor head.
- At night time, no red LED will be visible.
- To switch the unit back into Auto Mode, flick the internal wall switch/circuit breaker (OFF/ON) once within 1 second. The unit will return to Auto Mode. This is indicated by the return of the left to right scrolling LED's as described in Automatic Operation above.

Holiday Mode – Single LED Flashing

The benefit of Holiday Mode is that the user can program the unit automatically illuminate for a certain time, (1 – 8 hours) each night. At dusk the unit will illuminate for this set period after which it will extinguish. The unit will continue to operate normally when it senses movement until dawn. At dusk the following

night the process will be repeated, the unit will remain on for this set period (0 – 8 hours) and then will operate as a PIR unit until dawn.

- Switch the internal wall switch/circuit breaker 3 times (off/on off/on off/on) within 2 seconds. A single flashing red LED at the top of the sensor head indicates Holiday Mode.
- The unit will now illuminate for a user defined time between 1 and 8 hours. The time can be set by rotating the centre adjustment knob as required. (See diagram G, the adjustment knob is identified by the letter T inside a circle.)
- This time adjustment is factory set to 1 hour.

Note: Fully anti-clockwise is 1 hour, fully clockwise is 8 hours.

- After the defined period has elapsed, the unit will return to Automatic Mode and operate as previously set up and the three scrolling LED's will illuminate from left to right.
- Holiday Mode will NOT reset to Automatic Mode at dawn, it will repeat each night until reset by the user.
- To cancel Holiday Mode, switch the internal wall switch/circuit breaker once (OFF/ON) within one second. The unit will turn to Automatic Mode indicated by the scrolling LEDs.

11. Troubleshooting

Problem

- Lamp stays ON all the time night and day.

Solution

The unit may be suffering from false activation. Cover the sensor lens completely with a thick cloth. This will prevent the sensor from "seeing" anything. If the unit now switches off after the set time duration and does not re-activate, this indicates that the problem was caused by false activation. The problem may be solved by slightly adjusting the direction/angle of the sensor head (see previous section).

Check LED status:- If a single LED is constantly visible, the unit is in Manual Override Mode and will illuminate until dawn or until reset to Automatic Mode. To reset to Automatic Mode, switch the internal switch/circuit

- The PIR keeps activating for no reason at random.

breaker off/on within one second. Automatic Mode is indicated by scrolling LEDs from Left to right. If a single flashing LED is visible, Holiday Mode has been selected. Switch the internal wall switch/circuit breaker OFF/ON with one second and the unit will return to Automatic Mode. The light will illuminate only when motion is detected. Automatic Mode is indicated by scrolling LEDs from Left to right.

- The PIR will not operate at all.

You may not be allowing the unit time to complete its warm-up period. Stand well out of the detection range & wait (the warm-up period should never exceed 5 minutes). Occasionally, wind may activate the PIR. Also passages between buildings etc. can cause a 'wind tunnel' effect. Ensure the unit is not positioned so as to allow detection of cars/people using public thoroughfares adjacent to your property.

- The PIR sensor will not operate at night.

Check that the power is switched ON at the circuit breaker/internal wall switch. Turn OFF the power to the unit & check the wiring connections (See section 6. Connection Diagram). Ensure no connections are loose. Check the lamp. If the lamp has failed, replace. Ensure that the lamp is seated correctly in the lamp holder.

The level of ambient light in the area may be too bright to allow operation at the current DUSK setting. During the hours of darkness, adjust the DUSK control slowly clockwise until the lamp illuminates. Refer to previous section for more details.

- The Unit activates during the daytime.

The level of ambient light in the area may be too dark for the current DUSK setting. During daylight, adjust the DUSK control slightly anti-clockwise. When the lamp load extinguishes, enter the detection area. If the PIR still activates, the setting is still too high. Repeat the above procedure until the PIR does not activate when you enter the detection area. Refer to previous section for more details.
- The PIR coverage is poor/sporadic.

The Unit may be poorly located. See section 4. Selection a Location, and relocate the unit.
- Detection range varies from day to day.

The PIR sensors are influenced by climatic conditions. The colder the ambient temp, the more effective the PIR will be. You may need to make seasonal adjustments to the sensor head position to ensure trouble-free operation all year round.

3 Year Guarantee

In the unlikely event of this product becoming faulty due to defective material or manufacture within 3 years of the date of purchase, please return it to your supplier in the first year with proof of purchase and it will be replaced free of charge. For years 2 and 3 or any difficulty in the first year, telephone the helpline on 020 8450 0515.

Note: A proof of purchase is required in all cases. For all eligible replacements (where agreed by Timeguard) the customer is responsible for all shipping/postage charges outside of the UK. All shipping costs are to be paid in advance before a replacement is sent.



If you experience problems, do not immediately return the unit to the store. Telephone the Timeguard Customer Helpline;

HELPLINE
020 8450 0515

or email helpline@timeguard.com

Qualified Customer Support Co-ordinators will be on-line to assist in resolving your query.



Deta Electrical Co Ltd
Panattoni Park, Luton Road,
Chalton, Bedfordshire, LU4 9TT
Sales Office: 020 8452 1112
or email csc@timeguard.com
www.timeguard.com