

## ATC PACIFIC WATER HEATING INSTALLATION AND OPERATION MANUAL

- W5-u      5 Litre Undersink water heater**
- W10-u     10 Litre Undersink water heater**
- W15-u     15 Litre Undersink water heater**

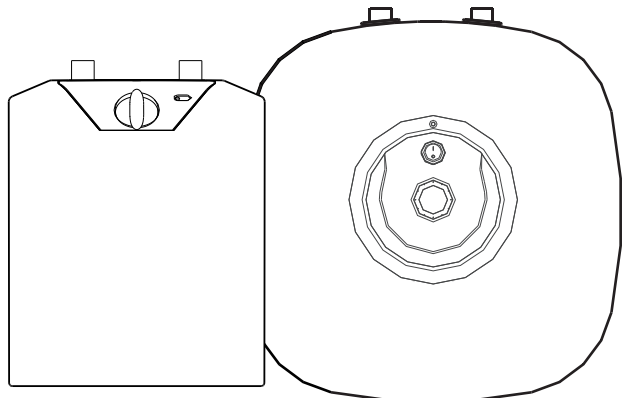

5 Litre heater

10 and 15 Litre heaters

**IMPORTANT SAFETY INSTRUCTIONS-READ BEFORE USING THIS WATER HEATER**

1. This water heater must be earthed.
2. Locate & install this water heater only in accordance with the provided installation instructions.
3. Use this water heater only for its intended use as described in this manual.
4. This water heater should be installed by a qualified installer.
5. Do not operate this water heater if it is not working properly or if it has been damaged or dropped.
6. This water heater should be serviced only by qualified service personnel.
7. Failure to examine and if necessary, replace the anode rod at least once a year could cause the tank to fail and leak and void the warranty.
8. Cable connection should be to a 13A double-pole Switched Spur.
9. **This water heater is not suitable for hard water areas unless a suitable water softener is fitted. In areas of hard water, failure to fit a water softener will cause premature unit failure and is not covered under warranty.**

**THESE INSTRUCTIONS SHOULD BE KEPT FOR FUTURE REFERENCE**

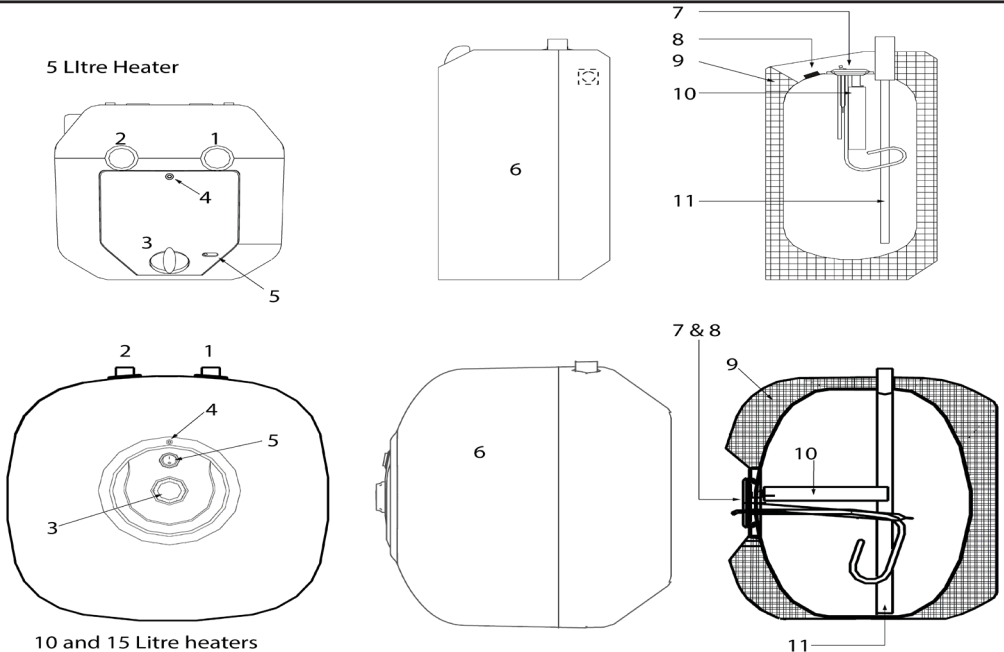

1	Cold water Inlet	5	Heating indicator (5ltr) LED On/Off Switch (10 & 15Ltr)	9	Thermal insulation
2	Hot water Outlet	6	Outer cover	10	Sacrificial Anode
3	Temperature adjustment	7	Electrical heating element	11	Cold water inlet
4	Cover Screw	8	High Level Thermal cutout		

## TECHNICAL SPECIFICATIONS

Product Code		W5-U	W10-U	W15-U
Capacity	Litres	5	10	14
	Gallons	1.1	2.2	3.3
Power	Watts	2000		2500
Voltage	Volts	220-240		
Frequency	Hertz	50-60		
Maximum Pressure	Bar	8		
Safety valve Max. Pressure	Bar	6		
Minimum Operating Pressure	Bar	1		
Connection Type		1/2" Male BSP		
Distance Between Connections	mm Center to Center	100		
Thermostat Type		Capillary type		
Thermostat Range	°C Min - °C Max	30-80	35-75	
External Switch		No	Yes	
Heating Indicator	LED	Yes		
Installation location		Undersink, wall mounted or standing on rubber feet*		
ERP Class		B	B	
Heating Time (minutes)	ΔT 35°C	7	13	15
	ΔT 45°C	9	17	19
Dimensions	Height	285	300	337
	Width	240	340	364
	Depth	240	330	354
IP Rating		X4		
Weight (kg)	Empty	4.5	6.5	8
	Full	9.5	16.5	23

\* The ATC Pacific water heaters are supplied with Adhesive rubber pads to mount on the bottom of the heater to allow them to stand rather than be wall mounted.

NOTE: The installer should review the contents of this manual with the owner on completion of the installation.

## GENERAL WIRING DIAGRAM

### Wiring diagram

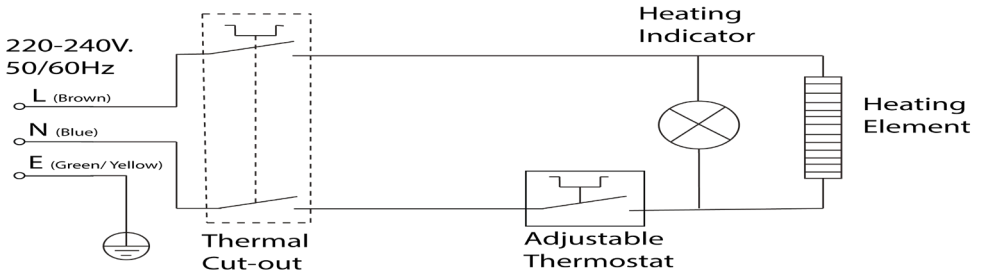

## HEATER MOUNTING INSTRUCTIONS

The water heater should be installed close to a water drainpipe so that excess water from the safety relief valve can drain away without harm; this drain pipe should always be kept free of obstruction.

Fix the mounting bracket supplied with the heater to the wall; see below for dimensions of the holes required; always use screws that are suitable for the wall material and the weight of the heater otherwise the heater may pull the bracket off the wall.

Hang the water heater on the bracket.

Tug downwards on the heater to ensure that both "fingers" of the bracket are seated in the mounting slots.

The heater can also be stood on its base using the rubber feet provided for this purpose. Attach the four adhesive feet to the base of the heater before plumbing.

Confirm water piping orientation before wall mounting.

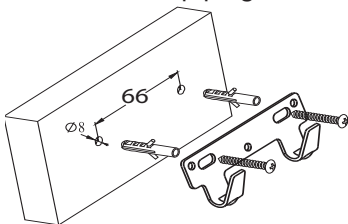

Concrete or Brick

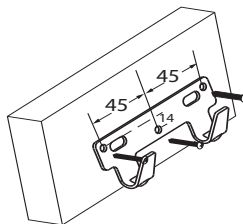

Timber or Plaster

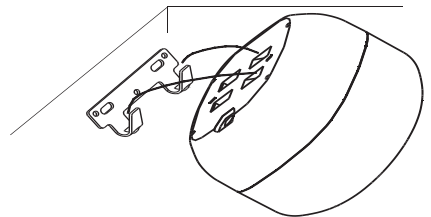

Hang the heater on the Bracket

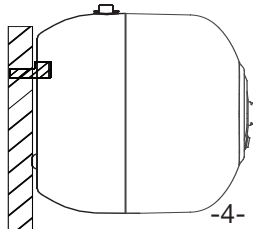
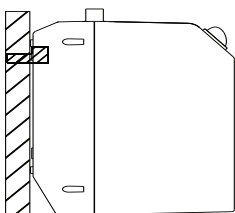

Note: If using the rubber feet, it is not necessary to use the wall bracket also. Should the installer wish to use the bracket as an additional fixing method, confirm location of bracket with feet attached to heater prior to installation.

## WATER PIPE CONNECTIONS

All water connections to the heater must be made in copper pipe. If using Qualpex or similar plastic piping method then a minimum of one metre of copper pipe must be installed between the heater and the plastic piping system. All pipework between the heater and the safety valve should be in copper and continue at least 1m from the water heater.

Connect the cold-water inlet pipe to the inlet connection (marked with a blue ring) and the hot water outlet pipe to the outlet connection (marked with a red ring). Dielectric Connections are supplied and should be used as necessary.

The water heater is designed for connection direct to the incoming mains water supply and accommodation must be made for the expanded water that will occur with each operating cycle. Regulations permit expanded hot water to be accommodated within the supply pipe work provided that an expansion relief valve is fitted (Check Local Regulations in your area). See drawing below.

### For Inlet water pressure up to 4.1 bar.

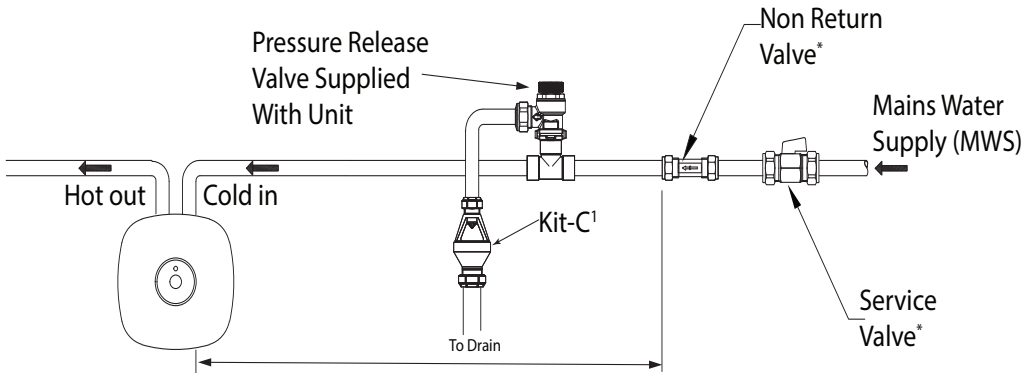

2.8m (5 & 10 Ltr) or 4.2m (15 Ltr) is required for expansion in pipework between cold water inlet and non return valve.

Where the expanded water cannot be accommodated in the pipe work due to space restrictions and the static water supply pressure is under 4 bar, an expansion vessel should be fitted in between the water heater and the safety relief valve.

Where static water pressures are likely to exceed 4 bar, fit a pressure reducing valve. Note: In this case expansion using the mains is not permitted and an expansion vessel must be used.

**-DO NOT LIE THE WATER HEATER ON ITS BACK. IT MUST STAND UP OR BE WALL MOUNTED ONLY-**

**For Inlet water pressure up to 4.1 bar where expansion in the mains is not possible.**

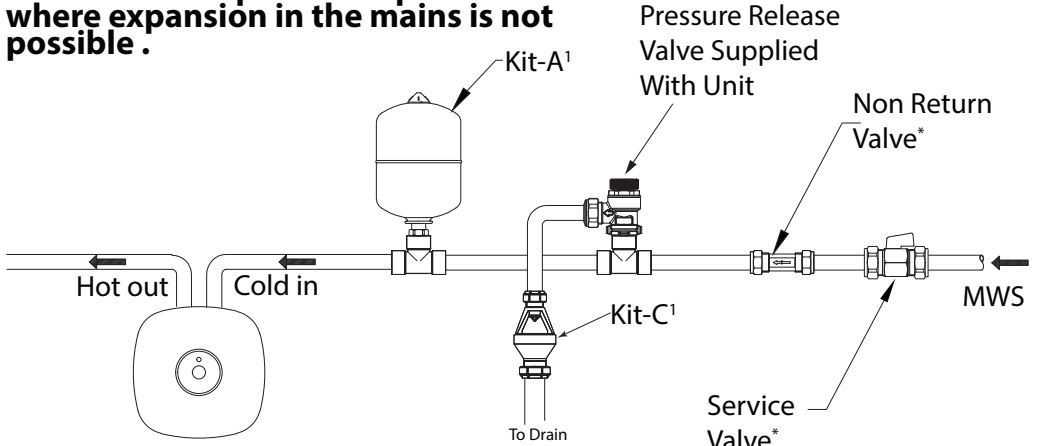

**For Inlet water pressure over 4.1 bar.**

Note: If a pressure reducing valve is used then allowing for expansion in the pipework is not possible. An expansion vessel must be used.

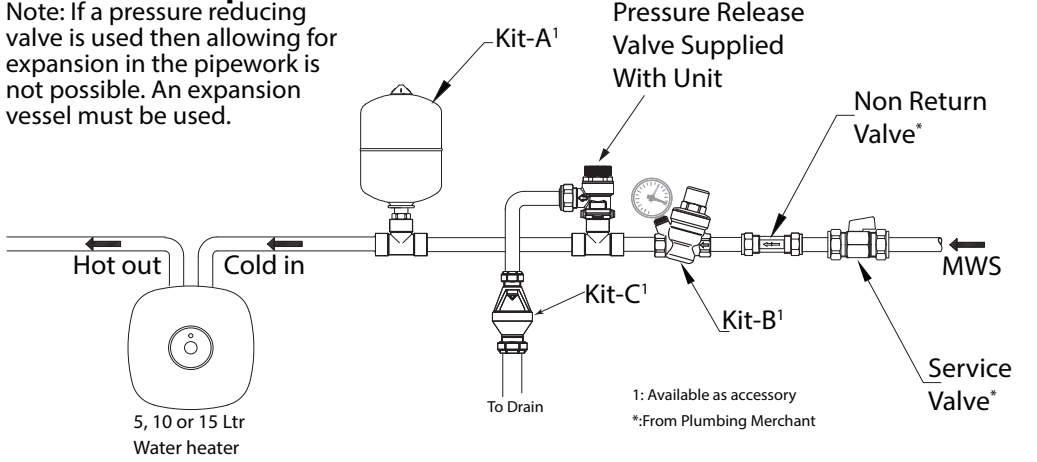

5, 10 or 15 Ltr  
Water heater

1: Available as accessory  
 \*:From Plumbing Merchant

## CLOSED SYSTEM THERMAL EXPANSION

There is a Pressure relief safety valve supplied with the water heater, the pressure relief outlet will allow a little water to escape when heating due to expansion of the water in the tank.

It is recommended to pipe this waste to a tun-dish (Kit-C) and then to waste. The safety valve has been pre-set in the factory to 6 bar, please do not adjust.

The Pressure Relief safety valve should be tested by twisting the top in an anti-clockwise direction until water flows out of the waste outlet; It is recommended that pressure relief valves are tested at least once every six months, especially to reduce leakage caused by the buildup of minerals and corrosion.

When water is turned off, reverse flow should be prevented using an appropriate non return valve. This is to prevent the element from operating without water in the tank.

Note: The outlet of the Pressure relief valve should be kept free of obstruction; it should be installed with the outlet pointing down and plumbed to waste. A tun dish (Kit-C) is available for this purpose

A 2 Ltr. Expansion vessel (Kit-A) and a Pressure Reducing Valve (Kit-B) are also available as optional accessories.

## ELECTRICAL CONNECTION

All ATC Pacific water heaters come pre-wired with 1.5mm<sup>2</sup> 2 core and earth. The heater should be connected by a suitably qualified electrician in accordance with IEE wiring regulations.

A suitable termination to the fixed wiring of the premises must be provided adjacent to the heater using a suitably rated double pole disconnection switch with a minimum of 3mm contact gap and protected by an appropriately rated circuit breaker or RCD.

If this heater is installed in a bathroom it must be supplied from a circuit that is protected by a high sensitivity RCD with a maximum rating of 30mA.

## OPERATING INSTRUCTIONS

- The water heater can be used by children of at least 8 years (as well as by persons with reduced physical, sensory or mental capabilities, or lack of experience or required knowledge) provided that they are under supervision, or after they have been instructed relating to the safe use and have understood the potential dangers.
- Children should not play with the water heater.
- Cleaning and maintenance must be performed by the user and not by unsupervised children.
- Children of less than 3 years should be kept away unless continuously supervised.
- Children aged from 3 years and less than 8 years shall only switch on/off the water heater provided that it has been installed in its intended normal operating position and they have been given instruction concerning use of the heater in a safe way and understand the hazards involved, children should always be supervised.
- Children aged from 3 years and less than 8 years shall not plug-in, regulate, clean the water heater or perform maintenance.
- Before connecting the water heater make sure that the voltage is the same as indicated on the device rating label.
- Do not use in presence of gas, inflammable or explosive liquids or substances as defined in BS5345.

## Start Up and Testing

Before connecting the power, fill the tank and system with water and check all the plumbing for leaks. Ensure that all air is out of the water system; open the hot water taps before

opening the service valve, open the service valve until constant water flows from the hot outlet. Once water is flowing, close the hot water tap. Failure to carry out this step can crack the lining of the heater and result in leaks.

### **To start the heating cycle:**

Make sure tank is full of water, otherwise damage to the water heater may occur.

For the 10 and 15 Litre heaters turn the switch on and then follow the 5Ltr instruction below.

For the 5 Litre heater, turn the temperature adjustment knob clockwise to 3/4 maximum and the indicator light will come on to show the element is heating. The indicator light will remain on until the temperature setting has been reached, at which point the light will go off. When the temperature drops below the set point of the thermostat the indicator light will automatically come back on. This is a “pilot light” indicating the unit is in the heating process.

### **To Set the Temperature.**

After the water heater has reached the set point outlined above check the water temperature — do not place hands directly under water outlet as there could be a risk of scalding. If it is necessary to adjust thermostat turn the dial clockwise to increase the temperature and anti-clockwise to decrease it.

## **PERIODIC MAINTENANCE AND PARTS REPLACEMENT**

### **Maintenance should only be carried out by a qualified service person.**

Note: For most of these operations the power supply should be turned off and the water will have to be drained from the heater.

### **Draining the Heater**

1. Isolate the power supply.
2. Shut off water inlet valve.
3. Remove water heater and invert over a sink to allow water to drain from tank safely.

### **Removing the Heating Element**

1. Turn off power supply and drain the heater (see previous section).
2. Remove the cover screw and cover.
3. Disconnect electrical cables attached to element.
4. Unscrew the heating element retaining nuts and remove compression bracket.
5. Remove the element.

### **De-scaling the Heating Element**

Scale deposits can dramatically affect the heating efficiency of the element. Heavy scale can even cause the element to burn out. The element can be descaled either chemically or manually:

1. Remove heating element (see previous section)
2. Soak the element in white vinegar or other descaling solution. Once descaled, rinse



the element well with fresh water, OR,

3. Once the element has dried up, use a soft brush (nonmetallic to prevent damaging the stainless-steel sheath) on element, and brush the dried mineral off.
4. Check and replace anode rod as required, (see below).
5. Reinstall the element with gasket and make the electrical connections.
6. Reinstall the water heater as per above normal installation procedure.
7. Refill tank with water before restoring power.

## **Changing the anode rod**

The anode rod helps protect the tank against corrosion. The magnesium anode rod needs to be inspected and changed every year.

Galvanic and electrolytic corrosion can be caused by non-municipal water supplies or low-level stray electrical currents in the water heater.

Galvanic and electrolytic corrosion can destroy a tank and can cause dirty water. If this happens examine the anode rod immediately.

Rapid degradation of the anode rod (less than 1 year) may indicate the presence of galvanic corrosion or high acidity/alkalinity in the water supply.

## **To replace the Anode:**

1. Turn off the power supply and drain the heater (see previous section).
2. Remove heating element (see previous section).
3. Remove the spent anode from the element by twisting the spent anode anti-clockwise and replace it with a new anode rod.
4. Replace heating element (see previous section).
5. Reinstall the water heater and refill tank with water before restoring power.

## **Changing the thermostat**

1. Turn off power supply.
2. Remove cover screw and cover. Remove dial from outside of cover.
3. Disconnect the spade connection wires on the on thermostat.
4. Remove and retain rubber plug holding the capillary sensor in the element and remove capillary bulb.
5. Unscrew and remove the screws holding the thermostat to the cover.
6. Install new thermostat and re-attach wiring and screws.
7. Re-install the capillary sensor into the sensor pocket hole in the element and install rubber plug into top of the sensor pocket.
8. Re-install cover and cover screw and reinstall adjustment dial.

## **Resetting the high-level thermal cutout**

Occasionally the high-level thermal cutout may trigger and shut the water heater down. This occurs when water temperature exceeds 93°C, at this temperature the high-level thermal cutout will shut off power to the heating element.

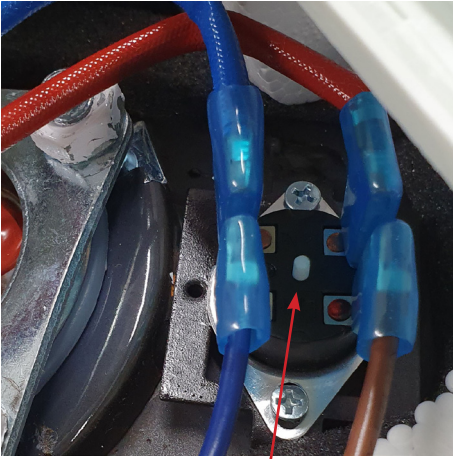

5 Litre Hi Level Reset

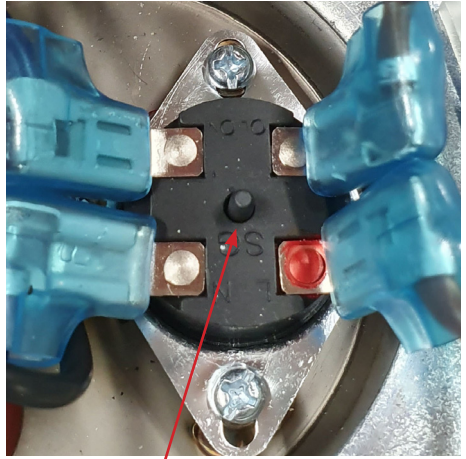

10 and 15 Litre Hi Level Reset

### To reset the High Level Thermal cutout:

1. **IMPORTANT:** Disconnect heater from electrical power.
2. Remove the cover screw and cover.
3. Firmly press reset button (see above) and listen for a “click”.
4. Replace the cover and cover screw.
5. Reconnect power.
6. **IMPORTANT:** Check the operation of the thermostat, turn temperature dial from high to low, if the red light does not go off on low setting, turn off the power supply, and call a qualified service person to replace thermostat.
7. If the system works, please set thermostat to desired setting.

Note: a lower setting is more economical, and reduces the risk of scalding.

**CAUTION:** Call a technician if the high limit needs to be reset frequently.

## TROUBLESHOOTING

### Water does not heat up

1. Make sure the power supply is on and there is power available.
2. If light does not come on, check that the reset button is pushed in; follow steps from previous section.
3. If the indicator light works properly but the temperature does not get hot at the tap, test for a plumbing crossover. Shut off cold supply to heater and open hot water tap. There should be no water flowing. Any continued flow indicates a crossover which will affect the temperature and will need to be corrected.
4. Replace heating element (see previous section on changing the heating element).

## Indicator Light not on

1. If the light does not come on, but water gets hot, check for faulty bulb.
2. Check reset button; follow steps from previous section.

## Brown water

1. Brown or rusty water indicates a “spent” anode rod. Replace anode rod.

## Odor in water

1. Smells from the water are usually due to an unusual reaction between local water and the heater’s anode, check anode rod.  
This usually occurs on non-municipal water supplies.

## Water is too hot

1. Turn the temperature selector dial counter anti-clockwise to lower temperature.
2. If temperature does not change then replace the thermostat.

## No Water flow

1. Check service valve is open and ensure minimum operation pressure is above 1 bar.  
Note: This water heater is not suitable for use on gravity fed systems.

## Unit Leaking

1. Check water connection fittings at the top of tank, ensure the connections to the water heater are sound and are not the cause of the leak; if they are leaking, tighten the connections.
2. Inspect heating element gasket for cracks or perishing if there are any signs of damage replace element and gasket together.  
NOTE: Elements and Gaskets should always be replaced together; do not reuse an old gasket.



## WARRANTY

ATC Electrical and Mechanical provides a two year limited parts warranty for the ATC Pacific water heaters as long as the unit has been installed, used and maintained in accordance with the information provided in this manual. For full terms and conditions of sale and warranty please see [www.atc.ie](http://www.atc.ie).

In order to arrange parts for the heater, the information listed below is required. It is recommended to write this information below and keep this instruction manual in a safe place.

Serial Number: \_\_\_\_\_ Date of Manufacture: \_\_\_\_\_

Date of Purchase: \_\_\_\_\_ Location Purchased: \_\_\_\_\_

ERP RATING INFORMATION				
Model		W5-U	W10-U	W15-U
Storage volume (V)	L	5	10	14
Declared load profile		 XXS	 XXS	 XXS
Water heating energy efficiency class		B	B	B
Water heating energy efficiency ( $\eta_{wh}$ )	%	32.0	32.0	32.0
Annual electricity consumption (AEC)	kWh	576	576	576
Sound power level ( $L_{WA}$ )	dB	15	15	15
Daily electricity consumption ( $Q_{elec}$ )	kWh	2.781	2.781	2.781
Mixed water at 40°C (V40)	l	---	---	---
Thermostat temperature settings of the water heater, as placed on the market	°C	75	65	65

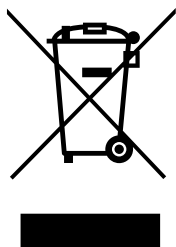

(Waste Electrical & Electronic Equipment)  
(Applicable in the European Union and other European countries with separate collection systems)

This marking shown on the product or its literature, indicates that it should not be disposed of with other household wastes at the end of its working life.

To prevent possible harm to the environment or human health from uncontrolled waste disposal, please separate this from other types of wastes and recycle it responsibly to promote the sustainable reuse of material resources.

#### Packing List:

- 1 Water heater
- 1 Mounting Bracket
- 4 Adhesive rubber feet
- 1 6 Bar Pressure Relief Valve
- 1 Instruction Manual
- 2 Dielectric Connectors
- 1 Bag of fixings

Household users should contact either the retailer where they purchased this product, or their local government office, for details of where and how they can take this item for environmentally safe recycling.

Business users should contact their supplier and check the terms and conditions of the purchase contract. This product should not be mixed with other commercial wastes for disposal.