

Installation Instructions

Luminaire Code(s) – **ABLED/3NM**

General Installation Instructions

These instructions should be read carefully prior to any installation and retained after completion for further reference and maintenance. Please give these instructions to the building owner/occupier after installation.

Important Safety

1. Before installation, maintenance or lamp replacement, ensure that the mains supply to the luminaire is switched off and the circuit supply fuses are removed or the circuit breaker is turned off.
2. It is recommended that only a qualified electrical contractor carries out the installation of this luminaire and that the luminaire is installed in compliance with the current edition of the IEE Wiring Regulations.
3. The person carrying out the installation is to check and verify that the total load on the circuit, including that of this luminaire does not exceed the rating of the circuit cable, fuse or circuit breaker.
4. Where a luminaire incorporates discharge control gear (inductive load), the circuit capacity and ratings require careful sizing to avoid nuisance tripping of the protective device used in the installation.
5. Where applicable, careful consideration should be taken during installation to ensure that all fixings and/or suspensions are of a suitable size for the luminaire being installed.

Ratings

1. All luminaires are manufactured & tested in compliance with the requirement contained within BS EN 60598 and are CE marked.
2. All luminaires that are of Class 1 construction and that are marked accordingly, MUST be earthed.
3. All luminaires are designed to operate at 230Volts AC -6%/+10% = 216Volts to 252Volts. Do not operate outside these voltages.
4. All luminaires are only suitable for applications within their rated Ingress Protection limits as stated.
5. **Max Ambient Temperature 25°C**

INSTALLATION

- All leads from this unit are clearly marked
- Drill a hole in the desired surface (Cut Out - 60mm). Ensure the mounting location provides adequate distance from water pipes, electrical cables, ceiling joists or other structural obstacles.
- Bring through supply cable and connect to the Emergency Pack ensuring correct polarity is observed.
Connect as follows:-

PERMANENT LIVE (L)	BROWN OR RED	(continuous)
NEUTRAL (N)	BLUE OR BLACK	
EARTH	GREEN / YELLOW	
- Connect the battery pack.
- Insert the emergency pack through the aperture. The pack will require sufficient space behind ceiling to manoeuvre into position. It must not be mounted near any heat source or where the ambient temperature normally exceeds 25° C.
- Offer the luminaire through the aperture, bend back the springs and push gently into the ceiling. Do not install the luminaire onto new plaster or wet paint.
- Energise the permanent (unswitched) mains supply and check the status indicator illuminates and check the mains health operation of the lamp(s) if they are maintained.
- Allow the unit to charge for a least one hour before isolating the permanent mains supply to the unit to briefly check the operation of the lamp(s) in the emergency mode.
- Thereafter allow the unit to charge continuously for 72 hours as a primary commissioning charge before considering the unit to be fully operational to specification.

DIAGRAM

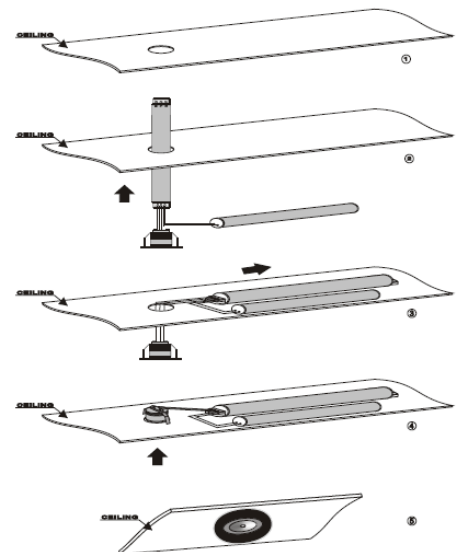
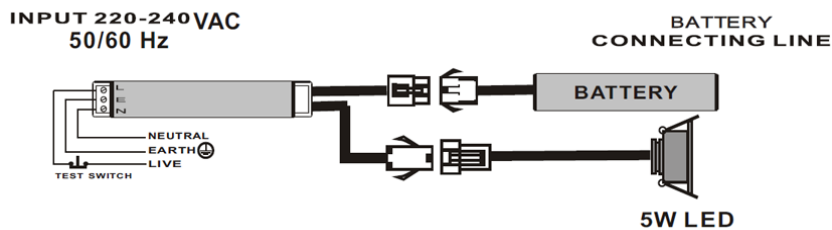

MAINTENANCE

- | | |
|---------------------|--|
| Daily : | Check LED indicator is illuminated. |
| Monthly : | Check the unit operates in emergency mode for ¼ of the rated duration. |
| Bi-Annually: | Check the unit operates of 1 hour for the 3 hour duration. |
| Three Years : | Check the unit operates for the full 3 hour duration. |
| Annually thereafter | Check the unit operates for the full 3 hour duration. |

If the unit fails to provide the required duration, replace the battery with one that meets the same specification.

Warning

- Disconnect the mains supply and unplug the battery leads before working on the unit.
- Failure to comply with these instructions may result in irreparable damage to the emergency control gear.
- This product must not be modified in any way as this will negate any Safety approvals, and may render the product inoperable or unsafe. The product must be installed in accordance with the instructions

Operating and recommended Routine Test Procedure

Follow these instructions carefully to ensure safe and reliable operation of this emergency luminaire. The following testing is designed to ensure the continued protection of your premises and occupants, in the event of the possibility of a failure of the normal lighting supply.

Testing should be carried out in accordance with the recommendations of BS5266-8-2004.

- **A daily check** – check LED charge indicator is illuminated
- **A monthly functional test** – simulate a mains supply failure for approx. 30 seconds by operation of key switch or switching off circuit breaker. Ensure normal supply is restored after test and ensure charge indicator is illuminated.
- **Every year, a full three hour duration test** - simulate a mains supply failure for a three hour continuous test by operation of key switch or switching off circuit breaker. Ensure normal supply is restored after test and ensure charge indicator is illuminated.

To assist with this testing, a test record is included. If the luminaire fails any of the above tests, please contact a qualified electrician.

TEST RECORD SHEET

MONTH	TEST	FIRST YEAR		SECOND YEAR		THIRD YEAR		FORTH YEAR		FIFTH YEAR	
		Signed	Date	Signed	Date	Signed	Date	Signed	Date	Signed	Date
1	FUNCTIONAL										
2	FUNCTIONAL										
3	FUNCTIONAL										
4	FUNCTIONAL										
5	FUNCTIONAL										
6	FUNCTIONAL										
7	FUNCTIONAL										
8	FUNCTIONAL										
9	FUNCTIONAL										
10	FUNCTIONAL										
11	FUNCTIONAL										
12	3 HOUR										

IP20



Disposal of Electronic Equipment WEEE Directive 2002/96/EC

This product falls within the scope of the Waste Electrical & Electronic Equipment Directive (WEEE), which means the product should not be disposed of as normal household waste. Ensure that this luminaire and lamp is disposed of in accordance with the WEEE Directive. Contact a local Council Waste Dept. Local Amenity Site, or the Environment Agency for further information. **RoHS** - All components and materials used in this product are **RoHS** 2002/95/EC compliant.

