

RESIDUAL CURRENT OPERATED CIRCUIT BREAKER WITH OVERCURRENT PROTECTION KR1P RCBO

1. MOUNTING

Residual current operated circuit breaker with overcurrent protection (RCBO) can be used in TN-S, TN-C-S, TT and IT network systems which means in all places where neutral and protective conductor are not connected. RCBO shall be mounted onto a rail of 35 mm according to EN 60715.

2. CONNECTION

Connections and internal connections are shown in figure A. The supply should be connected to terminal 1 and the blue neutral cable.

3. TECHNICAL DATA

Rated voltage U_N	~230 V
Rated current I_N	6 - 32 A
Rated residual current $I_{\Delta N}$	30 mA
Tripping characteristic	B and C
Rated short-circuit capacity	10 000 A
Rated frequency f_N	50 Hz
Energy limiting class	3
Line connection	1 - 25 mm ²
Load connection	1 - 16 mm ²
Standards	EN 61009, IEC 61009

4. MAXIMUM VALUES OF EARTHING RESISTANCE

U_L^*	$R_{E \max}$								
	50 V ~				25 V ~				
$I_{\Delta N}$	0,03	0,1	0,3	0,5	0,03	0,1	0,3	0,5	A
R_E	1660	500	166	100	830	250	83	50	Ω

U_L^* - touch voltage
Break time is < 0,04 s.

5. OPERATION

The conditions for correct operation of the RCBO:

- the phase conductor and the neutral conductor shall be conducted through the RCBO;
- the neutral conductor shall be behind the breaker insulated in the same way as the phase conductor, otherwise there can appear false or unwanted tripping;
- earthing resistances shall not exceed the prescribed values.

6. TESTING OF BREAKER OPERATION WITH THE TEST BUTTON

At least once in a half year the test button shall be actuated. On doing this, the RCBO shall switch off.

7. EXPLANATION OF THE SYMBOLS ON THE BREAKER



RCBO for residual sinusoidal alternating and residual pulsating direct currents



lower temperature limit of use of the RCBO

A

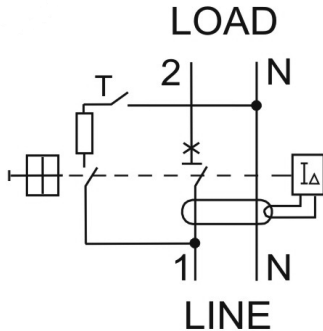

B

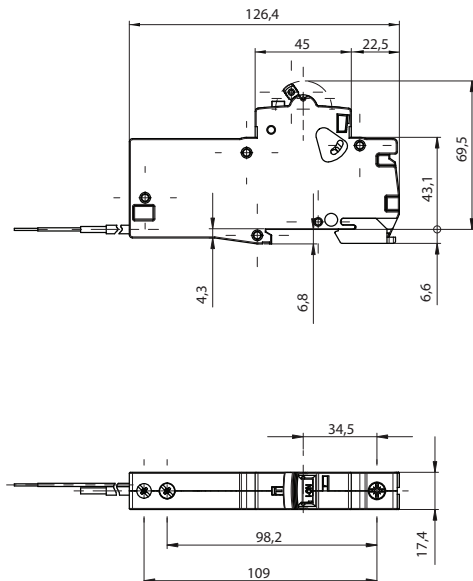

FIGURE A: THE INTERNAL CONNECTIONS, FIGURE B: DIMENSIONS