

Electric Towel Rails Models : S50W & S50C

08/17199/9 (UK) Issue 9

Dimensions

(millimetres)

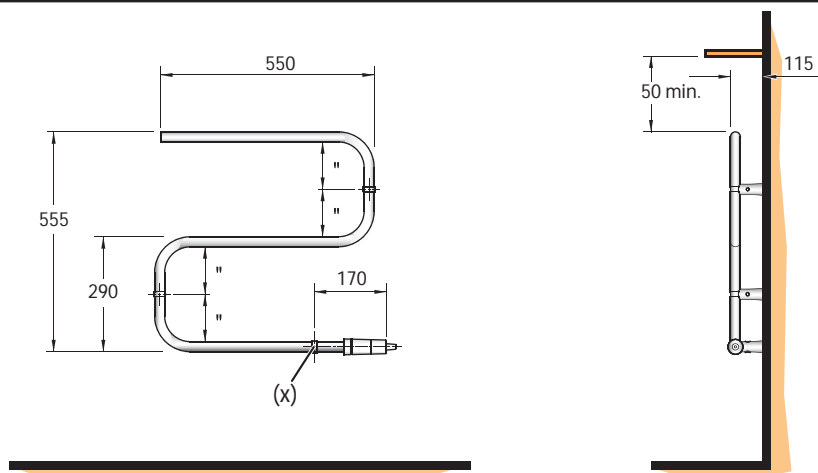

Fig. 1

IMPORTANT : THESE INSTRUCTIONS SHOULD BE READ CAREFULLY AND RETAINED FOR FUTURE REFERENCE

Important Safety Advice

WARNING - THE SURFACE OF THIS RADIATOR CAN BE HOT.

In order to be effective the towel rail will get hot, however momentary contact with any part of it should not cause injury.

WARNING - In order to avoid a hazard for very young children, this appliance should be installed so that the lowest heated rail is at least 600mm above the floor.

WARNING - This appliance must not be located immediately above or below a fixed socket outlet or connection box.

IMPORTANT - If the towel rail is to be installed in a place used by the public, a warning notice should be placed adjacent to the rail advising that the surface can be hot.

CAUTION - This appliance is not intended for use by children or other persons without assistance or supervision if their physical, sensory or mental capabilities prevent them from using it safely. Children should be supervised to ensure that they do not play with the appliance.

The towel rail is to be installed so that switches and other controls cannot be touched by a person in the bath or shower.

IMPORTANT - If the supply cord is damaged it must be replaced by the manufacturer or service agent or a similarly qualified person in order to avoid a hazard.

Precautions should be taken to ensure that prolonged contact with the towel rail cannot occur. Particular care should be taken in confined areas where accidental prolonged contact with the rail could be more likely to occur.

This appliance should only be used to dry fabrics washed in water using commonly available detergents.

General

Your Dimplex electric towel rail has been designed to provide an all-the-year-round service for airing towels and articles of clothing. It is not intended to provide a sole heating service.

The Dimplex S50W & S50C Towel Rails are designed for wall mounting only, and are splash-proof.

The Dimplex Towel Rails have a loading of 45W and will therefore operate for 22 hours on one unit of electricity (1kWh).

Use

Your Dimplex electric towel rail can quite safely be left on continuously if desired without detrimental effect. When in use however no more than three layers of towelling or similar fabric should be draped over each rail. It is not advisable to leave very damp clothes or towels on the rail when it is not in use, as this may affect the finish.

The rail when in use, though hot to the touch, is not hot enough to scorch or burn towels or clothes. However, soap and detergents remaining in articles after washing can cause what appear to be scorch marks after being in contact with a hot rail. Care should be taken therefore to thoroughly rinse out all articles before airing.

Electrical

The electrical installation of this towel rail must be carried out by a competent electrician in accordance with the current I.E.E Regulations for Electrical Equipment. The towel rail is suitable for use on an A.C.~ electrical supply. Before installation check that the supply voltage corresponds with that marked on the rail.

WARNING - THIS APPLIANCE MUST BE EARTHED.

IMPORTANT - The wires in the mains lead are coloured in accordance with the following code:

GREEN and YELLOW	-	EARTH
BLUE	-	NEUTRAL
BROWN	-	LIVE

As the colours of the wires in the mains lead of this appliance may not correspond with the coloured markings identifying the terminals in your plug, proceed as follows:

The wire which is coloured GREEN and YELLOW must be connected to the terminal in the plug which is marked with the letter **E** or by the earth symbol \oplus or coloured green or green and yellow.

The wire which is coloured BLUE must be connected to the terminal which is marked with the letter **N** or coloured black.

The wire which is coloured BROWN must be connected to the terminal which is marked with the letter **L** or coloured red.

This appliance must only be used on A.C. mains supply of 230/240 Volts~.

In accordance with wiring rules a suitable means for disconnection must be incorporated in the fixed wiring.

If fitted in a room containing a bath or shower, to comply with the current I.E.E. Regulations, a cable outlet will be necessary with the supply to the heater controlled by a double-pole pull-cord switch having a contact separation of 3mm in each pole. The body of the switch should be situated as to be normally inaccessible to a person using a bath or shower.

Installation

The towel rail must be permanently fitted to the wall.

The rail must be so mounted that the top is at least 50mm/2" below any overhanging surface. Sufficient space must be left for access to the terminal cover screws without removing the rail from the wall. The rail can be mounted facing left or right, with the cable entry position at the bottom.

Wall mounting

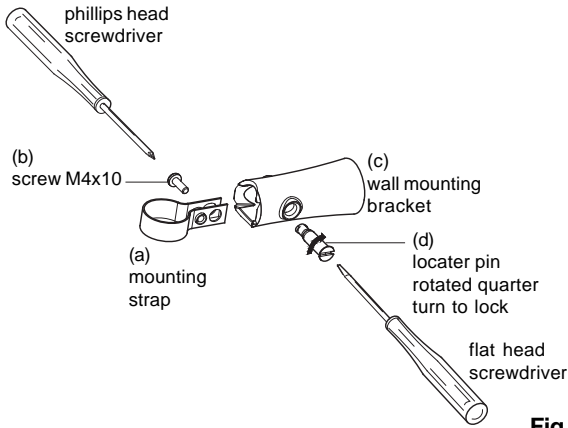

Fig. 2

The Wall mounting pack contains:

- (a) 3 mounting straps
- (b) 3 screws (M4 x 10)
- (c) 3 wall mounting brackets
- (d) 3 locater pins

Procedure for fixing Wall Brackets

Step 1

Mark the hole position (x) - see Fig. 1 - for the first fixing bracket and drill and plug the wall to suit. Fit the wall mounting bracket.

Step 2

Place the mounting strap carefully around the lower rail - see Fig. 3. Securely fix it by screwing in place fully the M4 x 10mm screw. Ensure the bracket is fitted with the rear of the strap facing directly backwards.

Step 3

Place the mounting strap into the wall mounted bracket, secure it with the locater pin by inserting it and giving it a quarter turn - see Fig. 3.

Note: Take care and hold the towel rail in position as one bracket is not sufficient to secure the towel rail to the wall.

Step 4

You now have a fixed point to help you mark the other hole positions for the other two wall mounting brackets. Remove the locater pin, and place towel rail carefully to one side to allow you to repeat Steps 1, 2 and 3, for the other brackets.

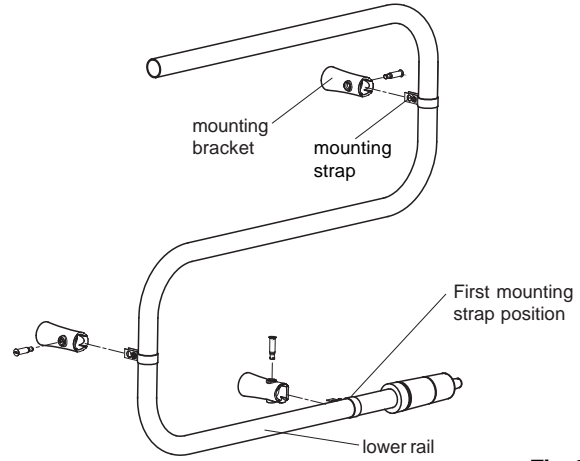

Fig. 3

To replace Cable

WARNING - The cable should only be replaced by a service agent or a similyary qualified person.

To gain access to the terminals first remove the two screws holding the cover in position. These screws are on top and underneath. Remove the screw from the bottom moulding. Remove the top cover with the neon lens and connect the wires as shown in Fig. 4 below.

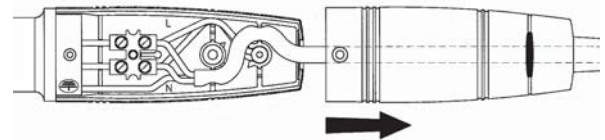

Fig. 4

Cleaning

The finish on your towel rail can be maintained by occasionally wiping over with a damp cloth and lightly finishing with a soft dry cloth. This should only be carried out when the rail is cold. **Do not** use abrasive cleaning powders as this could damage the surface finish.

Recycling

For electrical products sold within the European Community. At the end of the electrical products useful life it should not be disposed of with household waste. Please recycle where facilities exist. Check with your Local Authority or retailer for recycling advice in your country.

After Sales Service

Your product is guaranteed for two years from the date of purchase. Within this period, we undertake to repair or exchange this product free of charge (subject to availability) provided it has been installed and operated in accordance with these instructions.

Your rights under this guarantee are additional to your statutory rights, which in turn are not affected by this guarantee.

Should you require after sales information or assistance with this product please go to www.dimplex.co.uk where you will find our self help guide by clicking on "After Sales" or ring our helpdesk on 0845 600 5111 (UK) or 01 842 4833 (R.O.I.) .

Spare parts are also available on the website

www.dimplex.co.uk

Please retain your receipt as proof of purchase.

CE The product complies with the European Safety Standards EN60335-2-46 and the European Standard Electromagnetic Compatibility (EMC) EN55014, EN60555-2 and EN60555-3. These cover the essential requirements of EEC Directives 2006/95/EC and 2004/108/EC

Dimplex UK Ltd.
Millbrook House
Grange Drive
Hedge End
Southampton
Hampshire. SO30 2DF

TEL: 0845 600 5111
FAX: 01489 773050
WEBSITE: www.dimplex.co.uk
Republic of Ireland Tel. 01 8424833

[c] GDC Group Ltd.
All rights reserved. Material contained in this publication may not be reproduced in whole or in part, without prior permission in writing of Dimplex.
A division of GDC Group Ltd,