

Surface Mounted Microwave Sensor



AVAILABLE FINISHES



CODE	DESCRIPTION
OVMS001WH	360° Low Profile Surface Microwave Sensor

PRODUCT INFO	
Voltage	220-240V~
Frequency	50/60Hz
Operating Temp	-20°C - +40°C
Load Rating	1000W (LED) / 2000W (Incan.)
Detection Angle	360°
Detection Range	16M Diameter at 6 Metres
Adjustable Time	10 Sec. - 12 Mins.
Adjustable Lux Level	3 - 2000lx
Sensitivity	4 - 16 Metre Diameter
IP Rating	IP20

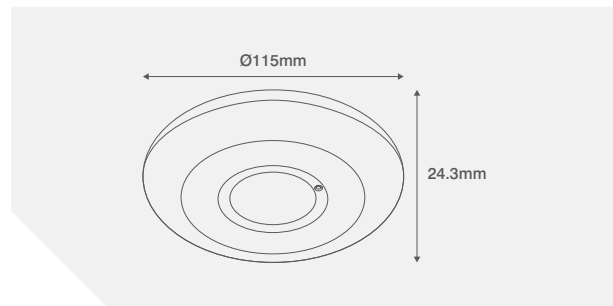

Zero Cross Technology

PRODUCT APPROVALS

EN 60669-1 EN 60669-2-1 EN 61547 EN 55015 EN 61000-3-2 EN 61000-3-3



Surface Mounted Microwave Sensor

AVAILABLE FINISHES



PRODUCT INFO	CODE	DESCRIPTION
	OVMS002WHD	360° 1-10V Dimmable Microwave Sensor

Voltage	220-240V~
Frequency	50/60Hz
Dimmable	1-10V
Operating Temp	-20°C - +40°C
Load Rating	1000W (LED) / 2000W (Incan.)
Detection Angle	360°
Detection Range	20M Diameter at 15 Metres
Adjustable Range	50%, 100%
Stand-by Period	5, 30, 90Sec., 3, 5, 10, 20 & 30Mins.
Stand-by Dimmed Level	10%, 20%, 30% & 50%
Adjustable Lux Level	2, 10, 50, 2000lx

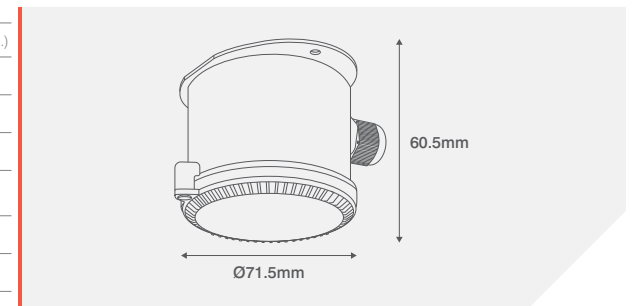

PRODUCT APPROVALS

Zero Cross Technology

EN 61058-1 EN 61547 EN 55015 EN 61000-3-2 EN 61000-3-3

