

IP44 600mm x 600mm LED Panels

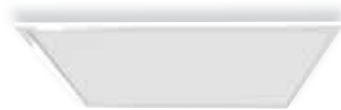

AVAILABLE FINISHES



CODE	DESCRIPTION
OV75301WW	30W LED Panel - 3000K - White
OV75301CW	30W LED Panel - 4000K - White

COLOUR TEMPERATURE



PRODUCT INFO

CCT (K)	3000K	4000K
Lumens	3150lm	3250lm
Efficacy	105lm/W	105lm/W
Wattage	30W	
CRI	>80	
Beam Angle	90°	
LED Lifetime	30,000 Hours	
Voltage	220-240V ~	
Frequency	50/60Hz	
Dimmable	Non-Dimmable	
Operating Temp	-20°C - +40°C	
UGR	<19	
Flammability Rating	TP(a)	

COMPATIBLE PRODUCTS		
OVEMCG50	3 Hour Emergency Pack	See page 121
OVSURF731	600mm x 600mm Surface Frame Kit	See page 120
OVREC731	600mm x 600mm Recess Frame Kit	See page 120
OVSUSP731	Suspension Wire Kit	See page 120

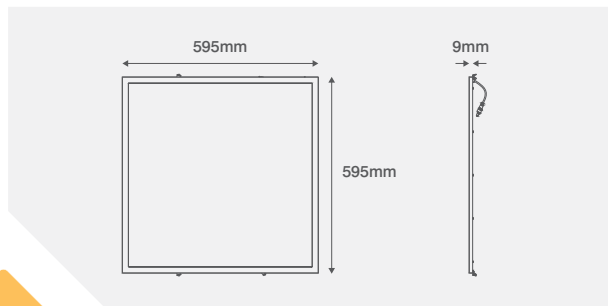

Complete with Remote Driver & prewired Flow™ Connector

PRODUCT APPROVALS

EN 60598-1 EN 60598-2-2 EN 55015 EN 61000-3-2 EN 61000-3-3 EN 61547 EN 61535



IP44 1200mm x 600mm LED Panel

AVAILABLE FINISHES



COLOUR TEMPERATURE



CODE	DESCRIPTION
OV75503CW	50W LED Panel - 4000K - White

PRODUCT INFO

CCT (K)	4000K	
Lumens	5250lm	
Efficacy	105lm/W	
Wattage	50W	
CRI	>80	
Beam Angle	90°	
LED Lifetime	30,000 Hours	
Voltage	220-240V ~	
Frequency	50/60Hz	
Dimmable	Non-Dimmable	
Operating Temp	-20°C - +40°C	
UGR	<19	
Flammability Rating	TP(a)	

COMPATIBLE PRODUCTS		
OVEMCG50	3 Hour Emergency Pack	See page 121
OVSURF733	1200mm x 600mm Surface Frame Kit	See page 120
OVSUSP733	Suspension Wire Kit	See page 120

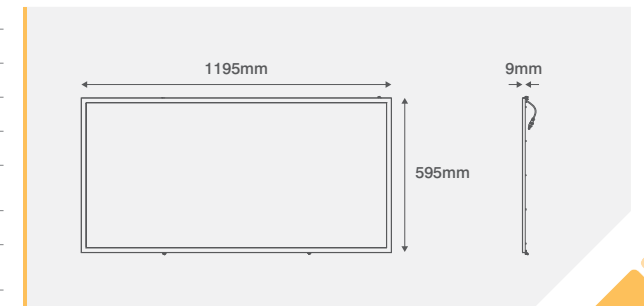

PRODUCT APPROVALS

Complete with Remote Driver & prewired Flow™ Connector

EN 60598-1 EN 60598-2-2 EN 55015 EN 61000-3-2 EN 61000-3-3 EN 61547 EN 61535

