

# INCEPTOR® HION

## Technical Specification

Product Code: OVEMCGHBBKM3

Luckinslive 422357470



Description: Inceptor® Hion 5W 3 Hour Maintained IP65 Emergency Pack Black

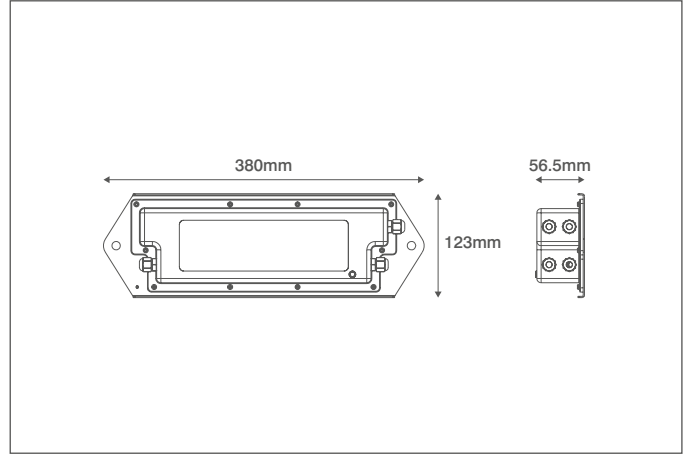

### General Information

Dimensions (mm)	380 (L) x 123 (W) x 56.5 (H)
Materials	Cover: Polycarbonate; Base: Powder Coated Steel
Colour	Black
Product Weight (Kg)	1.5
Ingress Protection	IP65
Warranty (Years)	4

### Supply & Power Information

Continuous Operating Voltage (AC) (Hz)	220-240 (50/60)
Safety Class	I
Power Consumption (W)	5
Input Current (mA)	<80
Output Voltage Range (V DC)	<55
Charge Time Minimum (Hours)	24
Power Factor	>0.5
Battery (Cells)	4
Rated Power (W)	5
Operating Temperature (°C)	0 to +40
Maximum Critical Temperature (°C)	+50
Input Mains Cable	4 x 1mm <sup>2</sup> H07-RNF (1 Metre)
Coupler Lead 1	2 x 1.00mm <sup>2</sup> H05RN-F (1 Metre)
Coupler Lead 2	3 x 1.00mm <sup>2</sup> H05RN-F (1 Metre)

### Emergency Backup Information

Installation	Can be wired as maintained or non-maintained
Minimum Duration (Hours)	3

### Compatible Fittings

Inceptor Hion Black Highbays



OVIA Limited, Scolmore House, Mariner, Lichfield Road Industrial Estate,  
Tamworth, Staffordshire, B79 7UL United Kingdom  
T: +44 (0)1827 300640  
E: sales@oviaUK.com | W: oviaUK.com



Catalogue



Section



DoC



Installation

